



**DAYTON TEXAS**

# **Engineering Design Standards and Details**

**January 2022**



**TABLE OF CONTENTS**

**TABLE OF CONTENTS ..... 1**

**PART 1: SITE DESIGN STANDARDS ..... 3**

1.1 Site Design Criteria..... 3

1.2 Extension Policies..... 4

1.3 Civil Infrastructure Design ..... 4

1.4 Grading..... 5

**PART 2: ROADWAY AND PAVING ..... 7**

2.1 Driveway and Curb Cut Standards ..... 7

2.2 Nonresidential Development Standards ..... 8

2.3 Sidewalks, Bikeways and Pedestrian Access ..... 8

2.4 Responsibility for Maintenance ..... 12

2.5 Public Streets ..... 13

2.6 Private Streets ..... 17

2.7 Turning Lanes..... 21

2.8 Traffic Impact Analysis ..... 21

2.9 Street Names and Signs..... 25

2.10 Conduit for Fiberoptic Cable..... 25

**PART 3: DRAINAGE ..... 26**

3.1 Drainage Design Standards ..... 26

3.2 Spread of Stormwater ..... 32

3.3 Public and private easements..... 33

3.4 Private Ponds..... 35

3.5 Floodplain Reclamation..... 36

3.6 Erosion and Sediment Control..... 44

3.7 Grading Permit..... 44

3.8 Stormwater Pollution Prevention Plan ..... 45

**PART 4: WATER SYSTEM ..... 49**

4.1 Water System Improvements..... 49

4.2 Water Lines and Services ..... 49

4.3 Water Meter Boxes..... 50

4.4 Water Valves..... 51

4.5 Fire Protection ..... 52

4.6 Fire Hydrants ..... 53

**PART 5: WASTEWATER SYSTEM..... 58**

5.1 Wastewater System Improvements ..... 58

5.2 Manholes and cleanouts ..... 59

5.3 Lift Stations..... 60

5.4 Force Mains ..... 66

5.5 On-site treatment ..... 66

5.6 Private Utility Provisions Services..... 67

**PART 6: CONSTRUCTION PLANS ..... 69**

6.1 General..... 69

6.2 Street Improvement Plans..... 69

6.3 Sanitary Sewer and Water Plans..... 69

6.4 Site and Paving Plans ..... 69

6.5 Drainage Plans ..... 70

6.6 Grading Plans.....	71
6.7 Erosion and Sediment Control Plans.....	71
6.8 Plan and Profile Sheets.....	72
6.9 Detail Plans.....	72
<b>PART 7: PERMITS.....</b>	<b>73</b>
7.1 Construction Permits .....	73
<b>PART 8: CONSTRUCTION AND INSPECTION .....</b>	<b>74</b>
8.1 General.....	74
8.2 Inspection.....	74
8.3 Final Inspection.....	74
8.4 Record Drawings.....	75
8.5 Acceptance By The City .....	75
8.6 Issuance of Building Permits.....	75
<b>PART 9: LIST OF APPROVED EQUIPMENT MANUFACTURERS .....</b>	<b>76</b>
<b>PART 10: STANDARD CONSTRUCTION DETAILS.....</b>	<b>82</b>

**APPENDICES:**

Appendix A: Road Use Agreement Form

## PART 1: SITE DESIGN STANDARDS

### 1.1 Site Design Criteria

A. All streets, alleys, sidewalks, drainageways, water and sewer lines, and improvements shall be designed, placed and constructed in accordance with Chapter 14: Unified Development Code, latest version, as published by the City of Dayton, with all amendments thereto, except as amended or conflicted by these engineering design standards. To the extent that there is a conflict between the regulations in this chapter and those found elsewhere, the regulations found in this chapter shall control development within a planned development district.

B. No final plat shall be approved by the City Council, and no completed improvements shall be accepted by the City or its representatives, unless and until such improvements conform to the City of Dayton Design Standards and Specifications and all other applicable standards as prescribed by the City of Dayton.

C. Developer is responsible for construction of all required public improvements related to the development. At City discretion, Public Works Director may install residential water taps for small developments.

D. Adequate public facilities policy. The land proposed for subdivision or development must be served adequately by essential public facilities and services. Land shall not be approved for platting unless and until adequate public facilities exist or provision has been made for water facilities, wastewater facilities, drainage facilities and transportation facilities which are necessary to serve the development proposed, whether or not such facilities are to be located within the property being platted or off-site. This policy may be defined further and supplemented by other ordinances adopted by the city.

E. Conformance to plans. Proposed public improvements shall conform to and be properly related to the transportation plan of the city's adopted comprehensive plan, other adopted master plans for public facilities and services, and applicable capital improvements plans.

F. Water. All platted lots must be connected to a public water system that is capable of providing water for health and emergency purposes, including adequate fire protection. Additional standards and requirements are defined herein.

G. Wastewater. All platted lots must be served by an approved means of wastewater collection and treatment. The city may require the phasing of development and/or improvements in order to maintain adequate wastewater capacity. Additional standards and requirements are defined herein.

H. Streets. Proposed streets shall provide a safe, convenient, and functional system for vehicular and pedestrian circulation and shall be properly related to the plan and any amendments thereto and shall be appropriate for the particular traffic characteristics of each proposed subdivision or development. Additional standards and requirements are defined herein.

I. Drainage. Drainage improvements shall accommodate potential runoff from the entire upstream drainage area and shall be designed to prevent overloading the capacity of the downstream drainage system. The city may require the phasing of development, the use of control methods such as retention or detention, and/or the construction of off-site drainage improvements in order to mitigate the impacts of the proposed development. Additional standards and requirements are defined herein. Improvements shall not damage other property per Texas Water Code.

J. Other facilities. Adequate sites and convenient access for schools, parks, playgrounds, and other community services indicated in the city's comprehensive plan shall be related to the character and uses of the surrounding properties in accordance with the intent, policies, and provisions of this chapter.

K. Phasing. The city may require the phasing of development or improvements in order to maintain current levels of service for existing public services and facilities or for other reasons based upon maintaining the health, safety, and general welfare of the city's inhabitants. The council shall determine whether the proposed public facilities and services are adequate pursuant to standards herein established.

### **1.2 Extension Policies**

---

A. Extensions to serve developments. All public improvements and required easements shall be extended through the parcel on which new development is proposed. Streets, water lines, wastewater systems, drainage facilities, and utility lines shall be constructed through new development to the next property line to promote the logical extension of public infrastructure. The city may require the owner of a development to extend off-site improvements to reach adjacent development or oversize required public facilities to serve anticipated future development as a condition of plat approval per the developer's rough proportionate share or through impact fees if the facility is listed as an impact fee eligible project.

#### **1.2.2 Extension of sanitary sewer or water mains for individual owners**

---

A. On-site septic facilities are not encouraged; therefore the applicant/developer shall extend sewer lines to connect to the City's sewer system. However, there are site specific circumstances that may require on-site septic facilities which the City Engineer may approve.

B. Upon request of the owner, or his agent, of a given lot or tract of land, for the purposes of this chapter known as the "applicant," accompanied by the payment of the charges due under this chapter, at the City's sole discretion may extend or cause to be extended, lay or construct all necessary sanitary sewer or water mains, including necessary appurtenances, excluding street intersections, plus the distance across the frontage necessary to provide the service for which application has been made. The applicant to be served shall be required to pay the charges herein provided for. The owners of all intervening property served by the given sanitary sewer or water main extension shall be required to pay the charges provided for herein at such time as their property is connected to the mains thus laid. Where an applicant for service secures an extension and service under this particular option for main extension, he shall pay the pro rata charges on all property owned by him and which is served by the extension required. The required extension of said main shall be figured in such manner as to leave out of the calculations that portion of any main adjacent to property already having other than temporary service, and for which the pro rata charges thereon have been paid or credited under the terms of this chapter.

C. Extension by special agreement with City Council: No provision of this chapter shall prohibit the City Council from entering into a special agreement or contract in a form acceptable to the City Council for the extension of sanitary sewer or water mains, which will assist in the orderly and beneficial development of the city.

### **1.3 Civil Infrastructure Design**

---

A. All public and private streets, thoroughfares, drainage facilities, water lines, sanitary sewer lines, street lighting and signage and other such facilities shall be designed in accordance with the most recent guidelines of the Engineering Design Standards and Specifications.

B. The standards set forth in the design manual are intended to be minimum requirements. The developer shall be responsible for determining if requirements that are more stringent are necessary for a particular development.

C. In cases where the design manual standards do not cover all aspects of a development, the owner will be expected to provide designs and facilities in accordance with engineering practice to the standard of care and construct facilities using first class workmanship and materials.

D. Floodplain regulation. All subdivision or development activity as regulated by this chapter shall be subject to Dayton Ordinance 3.700 Flood Damage Prevention and requirements set forth herein.

E. Building permits. Building permits may be issued either upon approval of the public improvements by the city, or upon entering a development agreement according to the City's requirements for completion of the improvements per the requirements of the Unified Development Code.

## 1.4 Grading

---

### 1.4.1 Site Grading

---

A. A lot grading plan is required for all developments.

B. Minimum and maximum lot grades. For single-family residential developments, front yard finished grades shall not exceed 12 percent. In all other cases, finished lot grades shall not exceed 4:1. The minimum lot grade, including the swale, shall be one percent for all lots. A four-foot clear swale top width shall be required. Swale drainage shall not be impeded by a fence.

C. Drainage. Areas that pond water are not permitted; except for designated detention ponds. All lots shall be graded away from the building pad within the grade limits specified above. There shall be no lot-to-lot drainage. All stormwater shall be routed to a public or private drainage easement, public right-of-way, or storm sewer.

D. Zero Lot Setbacks: Drainage for a zero-lot setback shall be discussed on a case by case basis

E. A permit shall be obtained from the City prior to commencement of any of the following:

1. Grading, excavation, land clearing, or any activity precedent to development of open, vacant, or unimproved land.
2. Dredging, filling, grading, excavation, or clearing of land within any FEMA designated floodplain or floodway areas.

F. Retaining walls. Where the maximum grade requirements cannot be otherwise met, the owner shall install permanent retaining walls.

1. Construction materials. Permanent retaining walls shall be constructed from reinforced concrete or reinforced masonry. Other durable retaining wall materials may be used with the approval of the City Engineer. Wood products may not be used to construct permanent retaining walls.

2. Design of retaining wall. Retaining walls more than 24 inches in height as measured from the top of the footing to the top of the wall shall be designed by a registered professional engineer. The design shall be based on a soils report that establishes both the active and passive lateral soil pressures to be used in the design of the wall. The soils report shall be submitted with the plans and permit application.

3. Permits for retaining walls. Permits are required for all retaining walls. The permit application shall be filed with the building official on forms established by the City. All information required by the building official shall be furnished. If the retaining wall design is included with the approved construction plans for a subdivision or development, no permit is required.

G. Debris and waste. No cut trees, timber, debris, large rocks or stones, junk, rubbish or other waste materials of any kind shall be buried in any land or left or deposited on any lot or street at the time of final acceptance by the city, and removal of those items and materials shall be required prior to such acceptance. Burning is not an approved disposal method. No items and materials as herein described shall be left or deposited in any area of the subdivision or development at the time of expiration of any public improvement agreement or acceptance of dedication of public improvements, whichever is sooner. However, dirt or topsoil may be stockpiled on a property at a location approved by the City Engineer that does not impact drainage.

H. Finished Floor Elevations. Where lots are not adjacent to a natural or excavated channel (or floodplain), the minimum finished floor elevations shall be no less than six (6) inches above the top of curb. For non-curbed streets and alleys, the minimum finished floor shall be no less than six (6) inches above the crown of the nearest street or edge of pavement of the alley.

#### 1.4.2 Street Grading.

---

A. Slopes. The minimum gutter slope for all streets shall be 0.50 percent. The maximum gutter slope shall be 5 percent. Cul-de-sac slopes shall be a minimum of 0.70 percent. Refer to Standard Details for cross-slope requirements.

B. Vertical Curves. Vertical curves shall be required for all cases when the algebraic difference in grades exceeds one percent. Elevations shall be shown on the construction plans at the beginning and end of curve, the PVI, and low point. Plans shall also include length of curve, beginning, end, and PVI stations, and curve K-value. Sag vertical curve lengths shall be based on stopping sight distance requirements. Crest vertical curve lengths shall be based on passing sight distance requirements.

C. Cross slope transitions. Cross slope transition lengths and design shall conform to AASHTO's *A Policy on Geometric Design of Highways and Streets*.



## PART 2: ROADWAY AND PAVING

### 2.1 Driveway and Curb Cut Standards

#### 2.1.1 Single- and Two-Family Driveways

A. Driveway widths. For 1- and 2-car garages, the width shall not exceed 18 feet, measured at the throat. For 3 car garages, the width shall not exceed 30 feet, measured at the throat, unless otherwise approved by the City.

B. Residential driveways shall be permitted onto residential streets only, unless an access from a residential street is not available. Driveways shall be located a minimum of 100 feet from any arterial or collector inter, measured from the right-of-way (ROW). This requirement can be waived by the City Engineer on a case-by-case basis. Driveways shall not be located within the entry drive of a subdivision.

C. Construction standards. See Standard Construction Details.

D. Driveway grades. Not greater than 8 percent or less than 1 percent at any point on the driveway. Within public right-of-way, not greater than eight percent if the driveway does not cross a sidewalk in public right-of-way, and two percent where crossing sidewalks in public right-of-way. Maximum cross slope on a driveway shall be no more than two percent on private property and not greater than the intersecting street grade on public right-of-way.

E. Number of driveways. One driveway is allowed per lot. If permitted by the City of Dayton Unified Development Code, a driveway may be connected to the street or the alley.

F. Distance from a driveway to a street intersection. Driveways that are connected to a street may not be constructed closer than 20 feet from a street intersection. The distance shall be measured from the edge of the driveway nearest the intersecting street to the projected ROW of the intersecting street. Driveways that are connected to an alley may not be constructed closer than 15 feet from a street/alley intersection, measured in the same fashion.

G. Spacing between driveways. The minimum distance between two adjacent driveways shall be no less than ten feet.

H. The radius or flare point at the street or alley of any driveway shall not extend beyond the intersection of the side property lines with the street or alley when projected. The minimum radius shall be four feet.

#### 2.1.2 Multiplex, Apartment, Non-Residential, and Mixed-Use Driveways

A. Driveway Widths. All driveway widths shall conform to Section 14.203.7 of the City of Dayton Unified Development Code.

B. Construction standards. See Standard Construction Details.

C. Driveway grades. Not greater than eight percent or less than one percent at any point on the driveway. Where driveways cross sidewalks in the public right-of-way, the maximum slope shall be two percent. Maximum cross slope on a driveway shall be no more than two percent on private property and not greater than the intersecting street grade on public right-of-way.

D. Number of driveways. One driveway is allowed for each 200 feet of lot width. For the purposes of this subsection, the lot width shall be measured at the street or alley ROW line. If permitted by Article 14.100 of the Unified Development Code, a driveway may be constructed at the street and the alley.

E. Distance from a driveway to a street intersection. Driveways that are connected to a street

may not be constructed closer than 100 feet from a street intersection, measured from the projected ROW. If the intersection is signalized or likely to be signalized as determined by the City Engineer, the driveway may not be constructed closer than 150 feet from the intersection. The distance shall be measured from the edge of the driveway nearest the intersecting street to the projected ROW of the intersecting street. Driveways that are connected to an alley may not be constructed closer than 35 feet from a street/alley intersection, measured from the back of curb or edge of pavement of the street/alley intersection to the edge of the driveway.

F. Spacing between driveways. All driveway spacing shall conform to Table 14.203.7-1 of the City of Dayton Unified Development Code.

G. Permits. Before a driveway may be constructed or a curb cut or modified on public rights-of-way a permit shall be obtained from the Director of Public Works. Permit applications shall be filed on forms provided by the City. Sketches, drawings, and other relevant information the Director may require shall be submitted with the application. The permit application shall be approved by the Director if all City standards have been met.

## **2.2 Nonresidential Development Standards**

---

A. Curb cuts. All nonresidential lots shall have access to the public street system by a driveway onto a public street or, in certain instances subject to review by the City Engineer, by a driveway onto a dedicated mutual access easement. Curb cuts shall be located in accordance with the master thoroughfare plan, public facilities design manual and other applicable ordinances.

B. Median openings. Median openings shall be located in accordance with the master thoroughfare plan and other applicable ordinances. Generally, median openings shall not be spaced closer than 350 feet centers nor closer than 250 feet from an intersection. If direct access to a median opening is not available, lots shall have indirect access through a mutual access easement between adjacent properties. Such mutual access shall be indicated on the plat. Median openings shall consider existing and future driveway locations and streets.

## **2.3 Sidewalks, Bikeways and Pedestrian Access**

---

A. Generally. The purpose of this section is to provide for the orderly, safe, and healthful construction of sidewalks within the City and to promote the health, safety, and general welfare of the community. In order to carry out these purposes, it is hereby declared the policy of the City to guide and regulate sidewalk construction within the City. This section shall comply with Section 14.302.9 of the Unified Development Code.

B. Sidewalks shall be constructed by the owner along all collector and arterial thoroughfares, and along all perimeter streets abutting the subdivision, regardless of whether such collector, arterial, or perimeter thoroughfare abuts a lot, alley, or other space. Sidewalks shall be constructed along all collector and arterial thoroughfares and perimeter streets prior to the issuance of a certificate of acceptance for the subdivision by the City.

C. Sidewalk size and locations. All sidewalks shall be at least five feet wide in both residential and nonresidential developments and shall be located between the curb or grade line of the public street and the ROW line or public access easement if approved by the City, no closer than five feet to the curb or grade line, unless otherwise approved by the City. The designated official may require that the sidewalk meander within the area between the curb and right-of-way line.

### **2.3.2 Residential subdivisions.**

---

A. The owner shall construct all sidewalks along the street right-of-way adjacent to parks, open space, amenity centers, drainageways, and other public or semi-public land. The owner is not

responsible, however, for constructing a sidewalk along the frontage, as herein defined, of any residential lot.

B. The owner of a lot is responsible for the construction of all sidewalks along the frontage, as herein defined, of such residential lot, including where such lot fronts on a collector thoroughfare, and along that portion of the lot that sides or rears to a street other than a collector or arterial. Provided, however, that such sidewalk is not required on a lot until completion of building construction. Upon completion of building construction, sidewalks shall be provided in accordance with the provisions contained herein. Authorization for occupancy shall not be granted until this requirement has been met.

#### 2.3.3 Nonresidential subdivisions.

---

A. Sidewalks shall be constructed prior to final acceptance of the subdivision by the City. Certificates of occupancy shall not be issued, and final inspections shall not be approved until this requirement has been met, or sufficient bond has been posted for the completion of the requirement.

B. Pedestrian accesses. The City may require, in order to facilitate additional pedestrian access from the streets to schools, parks, playgrounds, or other nearby streets, perpetual unobstructed mutual access easements at least 10 feet in width. Walkway widths shall be as determined by the City but may not be less than five feet wide. Easements shall be indicated on the plat.

C. Multi-use Paths/Bikeways. Multi-use paths (bikeways) shall be constructed along streets designated for multi-use paths or in other additional locations selected by the owner. Bikeways shall be not less than ten feet wide in a 12-foot mutual access easement.

D. Construction standards. See Standard Construction Details.

#### 2.3.4 Construction specifications.

---

A. Concrete requirements. Concrete for sidewalks shall have a minimum compressive strength of 3,000 psi at 28 days. The quantity of mixing water shall not exceed 6½ U.S. gallons per sack (94 lbs.) of Portland cement. The slump of the concrete shall not exceed four inches. A minimum content of five sacks of cement per cubic yard of concrete is required. Sidewalks shall be at least four inches thick.

B. Reinforcement. Sidewalks shall be reinforced with three-eighths-inch No. 3 bars set on 18-inch centers. Reinforcement shall be placed on steel or plastic standard reinforcing chairs before concrete is placed.

C. Expansion and control joints. Shall be in conformance with the City's standard details.

D. Sidewalk finish. The surface of the sidewalk shall have a monolithic broom finish. In no case shall the surface be left slick or with a glossy finish. The edges of the sidewalk control joints and expansion joints shall be tooled to a smooth finish not less than two inches in width. Exposed edges of the sidewalk shall be rounded with an edge to a radius of one-half inch.

E. Fire hydrant locations. Where a sidewalk is to be constructed and a fire hydrant would be within the forms, the forms shall curve around the fire hydrant such that the walk misses the fire hydrant by a minimum distance of one foot. A transition of ten feet is required in and out of curved areas. ADA requirements shall be considered.

F. Service and meter boxes. Where a sidewalk is to be built and a water meter box would be within the forms, a precast, concrete box shall replace the plastic box. This box shall have a hinged metal lid and be set at an elevation that will be equal to the finish grade of the sidewalk. If the owner so chooses, the owner may move the water meter box outside the forms at the

owner's expense.

G. Drainage. All sidewalks shall be built at an elevation that will not impede or be otherwise detrimental to proper lot drainage, with natural grade preferred.

#### 2.3.5 Wheelchair access ramps.

---

A. Location. A wheelchair access ramp must be constructed at any point a proposed sidewalk intersects a City street with the exception of walks leading from the street to the door of a residence. Access ramps must be constructed with a maximum one-inch wide expansion material between the street and ramp flush with the finish grade.

B. Grade. Care shall be taken to ensure a uniform grade meeting ADA requirements on the ramp, free of sags and short grades. Access ramps shall be built to grades no greater than one foot of fall per 12 feet in length.

C. Surface finish. Surface texture of the ramp shall be obtained by coarse brooming, perpendicular to the slope of the ramp.

D. Curb and gutter. The normal gutter line shall be maintained through the area of the ramp. Curb cuts for ramps shall be located as shown on street plans or as approved by the City Engineer.

E. Access ramps shall be per the Standard Construction Details and compliant with State and Federal Public Rights of Way Requirements.

F. Sidewalks, bikeways, and curb ramps shall be designed and constructed to meet the requirements of ADA Standards for Accessible Design (State and Federal Requirements).

#### 2.3.6 Responsibility for maintenance.

---

A. It shall be the duty and obligation of all owners and occupants of real property abutting sidewalks, drives, and approaches in the City, at their own cost and expense, to maintain and keep the sidewalks, drives, and approaches bordering their property level and free of depressions, excavations, elevations, inconsistencies, obstacles, obstructions or encroachments, natural or artificial, above or below ground level, or which overlap, impinge upon, or appropriate any part of the sidewalk area or the space eight feet above it. The City may require owners and occupants of real property to maintain and repair, at their own expense, sidewalks, drives, and approaches constructed after the effective date of the ordinance from which this chapter is derived and to obtain permits and inspections on said maintenance and repairs.

B. Any damage done to a sidewalk by the City or a City-hired contractor shall be repaired by the City or contractor.

C. Any damage done to a sidewalk by a franchised utility shall be repaired by the franchised utility.

D. The City may elect to initiate or implement a sidewalk participation program where the City may assist in all or portions of the costs associated with sidewalk maintenance repairs and replacements. The City's participation will be directed by the City Council as separate program that may be outlined in the different program.

#### 2.3.7 Provisions for adequate maintenance.

---

A. Inspection and notification. When the City determines that any section of sidewalk requires repairs or maintenance, a letter describing the necessary repairs will be sent to the adjacent property owner. The letter shall be given:

---

- B. Personally to the owner in writing; or
  - 1. By regular or certified mail to the owner's post office address; or
  - 2. If the letter cannot be delivered by personal service or by regular or certified mail, by publication in the official newspaper at least twice within ten consecutive days.
- C. The City reserves the right to address any deficient sidewalks at their own discretion.
- D. Time of response. The owner shall have 30 days from receipt of the notice, to make the necessary repairs. If weather conditions or other extenuating circumstances dictate, this 30-day period may be extended by the designated official, provided that the owner has contacted the designated official, with a plan for repairs prior to the expiration of the 30 days. This requirement may vary at the City's discretion.

#### 2.3.8 Failure to repair.

---

A. City action. Any repairs that are not performed by the owner, and which are determined to be hazardous to pedestrians or other users of the sidewalk, may be performed by the City or a City-hired contractor. After completion of repairs, the City shall send the adjacent property owner a notice that shall include:

- 1. Identification of the property;
- 2. A description of the violation;
- 3. A statement that the City made the necessary repairs;
- 4. A statement of the City's charges and expenses in making the repairs;
- 5. An explanation of the owner's right to request a hearing within ten days from receipt of the notice; and
- 6. A statement that if the owner fails or refuses to pay the expenses within 30 days from receipt of the notice, the City shall cause a lien against the property by filing with the county clerk a notice of lien and statement of expenses incurred.
- 7. Notice to property owner. The notice shall be given in the manner as provided in subsection.

B. Request for hearing. The owner may, within ten days from receipt of the notice in this section, file a written request for a hearing before City Council in order to contest the amount or validity of such costs. Upon receipt of a timely request, a hearing will be scheduled before the City Council. At the hearing, City Council shall determine whether the charges are reasonable and were properly assessed.

C. Filing of lien. If no hearing is requested, or if a hearing is held and the charges are determined to be valid, and the owner fails or refuses to pay such charges within 30 days from receipt of the notice to pay, City Council may assess the costs incurred against the adjacent property, whereupon the City shall file a notice of lien and statement with the county clerk of the costs incurred for the repair of the sidewalk and the City shall have a privileged lien on the property second only to tax liens and liens for street improvements. The notice of lien shall state the name of the owner if known, and the legal description of the property. Said privileged lien shall bear interest at the rate of ten percent per annum from the date the work was performed or payment therefor was made by the City.

D. Cost recovery. For any such costs and interest as aforesaid suit may be instituted and foreclosure had in the name of the City. Any statement so filed or a certified copy thereof shall be prima facie proof of the amounts expended for any such work and repairs.



## 2.4 Responsibility for Maintenance

---

- A. It shall be the duty and obligation of all owners and occupants of real property abutting sidewalks, drives, and approaches in the city, at their own cost and expense, to maintain and keep the sidewalks, drives, and approaches bordering their property level and free of depressions, excavations, elevations, inconsistencies, obstacles, obstructions or encroachments, natural or artificial, above or below ground level, or which overlap, impinge upon, or appropriate any part of the sidewalk area or the space eight feet above it. The city may require owners and occupants of real property to maintain and repair, at their own expense, sidewalks, drives, and approaches constructed after the effective date of the ordinance from which this chapter is derived and to obtain permits and inspections on said maintenance and repairs.
- B. Any damage done to a sidewalk by a city-hired contractor shall be repaired by the contractor.
- C. Any damage done to a sidewalk by a franchised utility shall be repaired by the franchised utility.
- D. The City may elect to initiate or implement a sidewalk participation program where the City may assist in all or portions of the costs associated with sidewalk maintenance repairs and replacements. The City's participation will be directed by the City Council as separate program that may be outlined in the different program.

### 2.4.2 Provisions for adequate maintenance

---

- A. Inspection and notification. When the city determines that any section of sidewalk requires repairs or maintenance, a letter describing the necessary repairs will be sent to the adjacent property owner. The letter shall be given:
- B. Personally to the owner in writing; or
1. By regular or certified mail to the owner's post office address; or
  2. If the letter cannot be delivered by personal service or by regular or certified mail, by publication in the official newspaper at least twice within ten consecutive days.
- C. The City reserves the right to address any deficient sidewalks at their own discretion.
- D. Time of response. The owner shall have 30 days from receipt of the notice, to make the necessary repairs. If weather conditions or other extenuating circumstances dictate, this 30-day period may be extended by the designated official, provided that the owner has contacted the designated official, with a plan for repairs prior to the expiration of the 30 days. This requirement may vary at the City's discretion.

### 2.4.3 Failure to repair

---

- A. City action. Any repairs that are not performed by the owner, and which are determined to be hazardous to pedestrians or other users of the sidewalk, may be performed by the city or a city-hired contractor. After completion of repairs, the city shall send the adjacent property owner a notice that shall include:
1. Identification of the property;
  2. A description of the violation;
  3. A statement that the city made the necessary repairs;
  4. A statement of the city's charges and expenses in making the repairs;

5. An explanation of the owner's right to request a hearing within ten days from receipt of the notice; and

6. A statement that if the owner fails or refuses to pay the expenses within 30 days from receipt of the notice, the city shall cause a lien against the property by filing with the county clerk a notice of lien and statement of expenses incurred.

B. Notice to property owner. The notice shall be given in the manner as provided in subsection.

C. Request for hearing. The owner may, within ten days from receipt of the notice in this section, file a written request for a hearing before the City Council in order to contest the amount or validity of such costs. Upon receipt of a timely request, a hearing will be scheduled before the City Council. At the hearing, the City Council shall determine whether the charges are reasonable and were properly assessed.

D. Filing of lien. If no hearing is requested, or if a hearing is held and the charges are determined to be valid, and the owner fails or refuses to pay such charges within 30 days from receipt of the notice to pay, the City Council may assess the costs incurred against the adjacent property, whereupon the city shall file a notice of lien and statement with the county clerk of the costs incurred for the repair of the sidewalk and the city shall have a privileged lien on the property second only to tax liens and liens for street improvements. The notice of lien shall state the name of the owner if known, and the legal description of the property. Said privileged lien shall bear interest at the rate of ten percent per annum from the date the work was performed or payment therefor was made by the city.

E. Cost recovery. For any such costs and interest as aforesaid suit may be instituted and foreclosure had in the name of the city. Any statement so filed or a certified copy thereof shall be prima facie proof of the amounts expended for any such work and repairs.

## **2.5 Public Streets**

---

### **2.5.1 General Street Requirements**

---

A. Adequate streets. Adequate streets shall be provided by the owner. The arrangement, character, extent, pavement width, right-of-way width, grade and location of each street shall conform to the comprehensive plan, the master thoroughfare plan, and this chapter, and shall be considered in its relation to existing and planned streets, topographical conditions, significant natural features such as mature trees or water courses, public safety and convenience, and its relationship to the proposed uses of land to be served by such street.

B. Intersection improvements. Intersection improvements and traffic control devices shall be installed as warranted in accordance with the traffic impact analysis, where required by these regulations, subject to participation standards in this chapter. The signals shall be installed in accordance with procedures specified in the state Manual of Uniform Traffic Control Devices.

### **2.5.2 Street Design Standards**

---

A. Street intersections shall be as nearly at right angles as practicable, giving due regard to terrain, topography, site distances, and safety. All arterial and collector streets, unless otherwise approved by the City Council, shall intersect at a 90-degree angle. Street centerline tangent and radii shall be as follows:

B. TABLE: STREET CENTERLINE TANGENT AND RADII

Right-of-Way Width (feet)	Minimum Tangent (feet)	Minimum Radius (feet)
50—60	50	300
60—70	50	400
70—80	100	600
90—120	250	1,000

C. The tangent distance is the minimum distance between two street centerline curves. Reverse curves and compound curves are not permitted where a minimum tangent distance is required. All geometric dimensions shall meet AASHTO requirements.

D. Half streets shall be prohibited, except under the following conditions:

1. When essential to the reasonable development of the subdivision in conforming with the other requirements of these regulations;
2. Where the City Council finds it will be practical to require the dedication of the other one-half of the street when the adjoining property is subdivided; and
3. Where the traffic impact analysis (TIA) demonstrates that the half street will accommodate the traffic generated by the development and existing developments.

E. Whenever a half street is allowed, the pavement width shall not be less than 24 feet. Where a half street is being dedicated along a common property line, the owner shall dedicate not less than one-half of the minimum right-of-way requirements as prescribed by this chapter. In no event, however, shall such dedication be less than 35 feet of right-of-way.

F. Where a half street exists, the owner of the property abutting the other side of the half street shall be required to construct and dedicate right-of-way for the remaining portion of the street.

### 2.5.3 Dead-end and cul-de-sac streets

A. Dead-end streets shall be prohibited except as temporary stubs to permit future street extension. In no case shall the length of such a temporary dead-end street exceed 250 feet. If such street exceeds 150 feet, then a temporary turnaround that meets fire department standards shall be provided.

B. Streets that terminate into a cul-de-sac shall not exceed 600 feet measured from curblines of the intersecting street to the center point of turnaround. The turnaround shall have an outside pavement radius of at least 50 feet (86-foot diameter bulb) and the distance from the pavement or curb shall not be less than 12 feet (110-foot diameter ROW bulb). All cul-de-sac turnarounds shall be visible from the intersecting street.

C. A sign shall be placed at the beginning of a dead-end street stating "No Outlet." Such sign shall meet city standards and be installed at the expense of the owner.

### 2.5.4 Street rights-of-way and Pavements

A. Street rights-of-way and pavement be as follows:

B. TABLE RIGHT-OF-WAY & PAVEMENT WIDTHS



Street Type	Existing		Future					
	Minimum ROW Width (feet)	Minimum Pavement Width (feet)	Median	Minimum ROW Width (feet)	Minimum Pavement Width (feet)	Number of Lanes	Lane Width (feet)	Sidewalks Required
Major Arterial	120	36	Divided	150	2 x 36	6 lanes	12	Yes
Minor Arterial	100		Undivided	120	60	5 lanes	12	Yes
Major Collector	75	44	Divided	90	2 x 26	4 lanes	14	Yes
Minor Collector	---	---	Undivided	75	36	3 lanes	12	Yes
Local	50	28	Undivided	60	28	2 lanes	14	Yes

C. As applicable, pavement widths shall be measured from the face of one curb to the face of the opposite curb for curbed streets and from edge of pavement to edge of pavement for non-curbed streets.

D. The planning and zoning commission may recommend, and City Council may determine that topography, length of street, existing street pattern, location of existing buildings, nature of the proposed land use, or other special conditions warrant a street of greater or lesser width. However, the relationship of pavement width to right-of-way width shall be consistent with the requirements of this subsection and the design standards.

E. Where new street construction is to be connected to an existing street of the same zoning designation, and where the existing street pavement width is less than that required herein, the pavement width of the new street may be adjusted to match the pavement width of the existing street, upon approval of the director of public works.

#### 2.5.5 Intersections

A. Major thoroughfare intersections shall be at 90-degree angles and tangent to the intersecting street for at least 50 feet. Other street intersections shall be laid out to intersect as nearly as possible at right angles and shall not intersect at least than 80 degrees.

B. No residential and collector (two lanes) street intersection with arterial streets (four lanes or larger) shall be allowed within 350 feet of the intersection of two arterial streets and/or within existing/proposed right turn lane limits.

C. Intersecting streets with centerline offsets of less than 300 feet, are not permitted.

#### 2.5.6 Sight distances and sight triangle

A. All intersections shall meet the line of sight requirements established by AASHTO for the highest design speed of any intersecting street.

B. Sight triangle definition. A sight triangle shall be the triangle created by connecting a point which is ten feet along the ROW at the intersection and a point extending away from the intersection a distance of 40 feet. This line shall extend by projection to the back of curb on improved streets or the edge of pavement on unimproved streets along both streets impacted. The sight triangle herein referenced shall include all area between the above-defined line and the street pavement.

C. Restriction. There shall be no tree, shrub, plant, sign, soil, fence, retaining wall, or other view obstruction having a height greater than two feet within the sight triangle as defined above. This height shall be measured above a line drawn between the top of curb or edge of pavement of both streets at the point where the referenced line intersects the top of curb or edge of pavement.

D. This restriction shall not apply to trees within the triangle having a diameter of less than 12 inches when such trees are trimmed at all times so that no branch or growth is less than seven feet above the above referenced measurement line.

E. Curbs shall be six inches in height. Curbs are required on all streets except for residential streets for subdivisions with a minimum lot size of one acre.

F. Design speed. The alignment and design of streets should be such that arterial streets have a safe running speed of 40 miles per hour, collector streets have a safe running speed of 30 miles per hour, and residential streets have a safe running speed of 20 miles per hour. City reserves the right to adjust design speeds for local conditions.

G. ~~The minimum grade of a street shall be 0.50 percent. The maximum grade for a residential street shall be ten percent. The maximum slope for a major collector or arterial shall be seven percent.~~

H. Vertical alignment profile grades of streets and alleys shall be connected by vertical curves of a minimum length as set forth in the design manual.

#### 2.5.7 Curvilinear design requirements

---

A. Compliance. Subdivisions located in the residential zoning districts that will contain lots of less than one acre in size shall design and provide for all minor and local streets in a curvilinear manner, except when:

B. In the determination of the planning and zoning commission the shape or topography of the subdivision, existing zoning or the pattern of the adjacent street system would make the provision of such curvilinear streets impractical.

C. The subdivision contains ten or less gross acres of land and was not acquired or conveyed out of a larger tract of land without benefit of plat approval and recording in accordance with the provisions of this chapter.

D. The subdivision is part of and conforms to an unexpired preliminary plat approved prior to the date of the approval of the ordinance from which this chapter is derived.

#### 2.5.8 Street construction

---

A. Residential street pavement shall be constructed of concrete that is six inches in thickness and 3,600 psi or greater, of Portland cement concrete. Mix shall have a six-sack mix with no fly ash substitute. Concrete reinforcing shall be No. 4 bars on 18-inch centers running both ways. Pavement crowning shall be a minimum of four inches and a maximum of six inches.

B. All street sub-grades shall be lime stabilized with hydrated lime in the amount of not less

than six percent by weight to a depth of six inches for the stipulated width plus one foot behind the curbs. However, for developments where the total street length is more than 1,000 linear feet, the lime percentage shall be determined from a lime series prepared by an independent laboratory paid for by the owner. The lime percentage shall be adequate to reduce the plasticity index of the subgrade to 15 or lower.

C. Major collector, arterial streets, and any street serving developments where more than five trucks per day with a gross vehicle weight of 50,000 are expected to travel the street the street pavement shall be eight inches in thickness of 3,600 psi or greater Portland cement concrete. Concrete reinforcing steel shall be No. 4 bars placed on 18-inch centers and running both ways. Pavement crowning shall be six inches in height.

D. No fly ash shall be allowed as a substitute for cement.

E. A geotechnical engineer shall recommend the pavement section through a geotechnical study that shall be provided to the City for review. Provide a minimum 25-year pavement design life.

## **2.6 Private Streets**

---

### **2.6.1 Variance Required**

---

A. Subdivisions may be developed with private streets instead of public streets if the development complies with the requirements of this section and the subdivision has received zoning approval for a private street development variance to these requirements shall not be considered.

### **2.6.2 General design and construction standards for private streets**

---

A. Private streets shall conform to the same standards regulating the design and construction of public streets. These standards shall include, but are not limited to, the following:

B. Developments proposed with private streets must submit to the city the same plans and engineering information required to construct public streets and utilities. Requirements pertaining to inspection and approval of improvements prior to final plat approval and acceptance of the subdivision shall be the same as public streets. The city may periodically inspect private streets and require repairs necessary to ensure safe emergency access. All standard requirements and fees will be applicable.

C. Water, sewer and drainage facilities, streetlights, and signs placed within the private street right-of-way or public utility easement shall be built to city standards or otherwise approved by the City Council. Unless otherwise stated on the plat or within the development agreements, all maintenance and operation costs of drainage facilities, streetlights, and signs shall be the responsibility of the property owner's association, homeowner's association, or homeowners, whichever is applicable.

D. The city shall not participate in the payment for any portion of the cost of constructing and maintaining a private street.

### **2.6.3 Property owner's association required**

---

A. A mandatory property owners association shall be established for all subdivisions developed with private streets or where public streets are converted to private streets.

B. Property owner's association documents.

1. For purposes of this chapter, the term "property owner's association documents" means the association articles of incorporation and bylaws and all other association documents affecting the activity and rights of property owners in the subdivision.
  2. The property owner's association articles of incorporation, bylaws, and declaration of restrictive covenants must be filed of record with the county in which the subdivision is located before the final plat is filed or before the city will convey existing public streets to the property owner's association.
  3. The declaration of restrictive covenants shall require the owners of all lots in the subdivision to be members of the property owner's association and shall require the payment of dues and assessments imposed by the association.
- C. The property owner's association documents shall include:
1. That the streets within the subdivision are private, owned and maintained by the property owner's association to city standards, and that the city has no obligation to maintain the private streets;
  2. Provisions that the city may use the reserve funds or assess the lot owners for street repair if the streets are not continually maintained to city standards;
  3. Which city services will not be provided on the private streets;
  4. Provisions describing the requirements of subsection (8) of this section; and
  5. A provision that the property owner's association, as owner of the private streets and appurtenances, agrees to release, indemnify, defend and hold harmless the city, any governmental entity and public utility for damages to the private street occasioned by the reasonable use of the private street by the city, governmental entity or public utility; for damages and injury (including death) arising from the condition of said private street; for damages and injury (including death) arising out of the use by the city, governmental entity or public utility of any restricted access gate or entrance; and for damages and injury (including death) arising out of any use of the subdivision by the city, government entity or public utility. Further, such language shall provide that all lot owners shall release the city, governmental entities, and public utilities for such damages and injuries. The indemnifications contained in this subsection apply regardless of whether or not such damages and injury (including death) are caused by the negligent act or omission of the city, governmental entity or public utility, or their representative officers, employees or agents. Those portions of the homeowner's association's document pertaining to the subject matter contained in this subsection shall not be amended without the prior written consent of the city.
  6. Maintenance Agreement. The portion of the property owner's association documents pertaining to maintenance of the private streets, assessments shall conform to the requirements of this section and shall not be amended without the written consent of the city. Notwithstanding anything herein, the city shall not be a party to any property owner's association, nor be allowed to enforce any private deed restrictions, covenants or restrictions.
  7. All property owner's association documents shall be reviewed and approved by the city attorney to ensure that they are legally sufficient to accomplish their intended purpose and that they conform to the requirements of this chapter and other applicable city ordinances prior to being filed of record at the county.

#### 2.6.4 Access restrictions

---

- A. The entrances to all private streets shall be marked with a sign stating that it is a private street. An access control gate, guardhouse or other means of restricting access to private streets shall be constructed. Gates must be located on private property. All gates and drives
-

shall accommodate government and utility personnel, U.S. Postal Service, solid waste collection, residents, guests, deliveries, etc., without impeding traffic movement on public thoroughfares. If the association fails to maintain reliable access as required to provide city services, the city may enter the subdivision and remove any gate or device that is a barrier to access at the sole expense of the association. The association documents shall contain provisions in conformity with this subsection that may not be amended without the written consent of the city.

B. The location and design of each entrance or exit shall accommodate peak travel times. Adequate stacking distance, not less than a total of 100 feet, shall be provided to allow for any delay in gate opening. The gate must setback from the public thoroughfare for a minimum distance of 50 feet with a turnaround provided for vehicles denied access to be able to exit onto a public street in a forward manner before getting to the gate. If an overhead barrier is used, it must have a minimum clear span of 14 feet in height above the road surface. At least two access points to public streets shall be provided for emergency vehicles. These access points shall be at least 24 feet wide, equipped with automatic gate activated by an Opticom controller, and include emergency standby power.

C. All gates shall comply with the city fire department regulations for emergency access. The owner shall install all necessary appurtenances for the access gates and provide to the city all equipment necessary to operate the access control devices as determined by the city at no cost to the city.

D. Visitor entrance design standards. At least one entrance to a subdivision with private streets shall be equipped for visitor access. In addition to the above restricted access entrance design standards, the visitor entrance shall be equipped with a call or code box located at least 50 feet from the boundary of the subdivision to provide for visitors calling in an automobile queuing. All buildings constructed in association with a visitor's entrance shall be constructed according to the provisions of chapter 36, zoning. A turnaround space with a minimum outside radius of 30 feet shall be located between any call or code box and the access control device to allow vehicles denied access to safely exit onto public streets in a "head out" position. A sign shall be erected next to the edge of such turn around space to prohibit vehicle parking in such space. A resident's entrance used in combination with a visitor entrance shall comply with the requirements of this subsection.

E. Waiver of services. The subdivision final plat and the property owners' association documents shall reflect that the streets are private and certain city services shall not be provided on private streets. Among the services that will not be provided are routine police patrol, enforcement of traffic and parking ordinances, and preparation of accident reports. All private traffic regulatory signs shall conform to the Texas Manual of Uniform Traffic Control Devices. Depending on the characteristic of the development, other city services may not be provided.

#### 2.6.5 Petition to convert public streets to private streets

---

A. Property owners in an existing subdivision may petition the city to become a subdivision with private streets. The petition will be accepted for consideration if it contains the signatures of the owners of 100 percent of the lots in the subdivision.

1. The conversion to private streets requires a public hearing and recommendation by the planning and zoning commission with a public hearing and approval by the City Council.

2. Upon the approval by the City Council, petitioners shall contract with the city for purchase of the installed streets from the city at a value to be determined by the City Council for cash

in full payment, and to maintain the infrastructure at city standards thereafter. For the purposes of this section, the term "streets" includes alleys.

B. Considerations for decision. The City Council has discretion in its consideration of private streets and is not required to approve a petition to become a subdivision with private streets. In deciding whether to approve or deny a petition, the council may, after receiving a recommendation from the commission, review the petition to determine whether private streets would:

1. Negatively affect traffic circulation on public streets;
2. Impair access to or from properties of future developments either on-site or off-site to the subdivision;
3. Impair access to or from public facilities including schools or parks;
4. Delay the response time of emergency vehicles;
5. Replace streets shown on the adopted thoroughfare plan;
6. Impede or cross an existing or proposed street as shown on the city's thoroughfare plan or any approved preliminary or final plats;
7. Disrupt an existing or proposed city public pedestrian pathway, hike and bike trail, equestrian trail, or park as shown on the city's most recent park, recreation and open space master plan or trail system master plan;
8. Negatively impact the continuity or sense of community in the city as a whole;
9. The provisions of subsection (4) of this section.

C. Property owner's association. A request for approval of the conversion of streets in a subdivision to private streets, shall be accompanied by a petition signed by all property owners in the subdivision and shall include all documents legally necessary to:

1. Create enforceable restrictive covenants that run with the land providing for assessments by a property owner's association for the maintenance of the streets;
2. Require membership in the property owner's association for the owners of all properties served by private streets;
3. Provide for the maintenance of the private streets and appurtenances after transfer of ownership from the city to the property owner's association;
4. Demonstrate that the property owner's association is financially able to purchase the streets from the city;
5. Ensure that the property owner's association shall not be dissolved without the written consent of the city.

D. Indemnity. The property owner's association shall indemnify the city as provided in this section.

E. Petition to convert to private streets to public streets. The city shall not be obligated to accept private streets as public streets at a later time. However, a private street subdivision may be converted to a public street subdivision with the following conditions:

1. A petition containing the signatures of 100 percent of property owners within the subdivision must be submitted to the city. The property owner association documents shall allow the association to request the city to accept private streets and associated property as public streets and rights-of-way upon written notice to all association members and the favorable vote of a majority of the membership, in accordance with the voting rights and procedures of the association.



2. An engineering report prepared by a registered engineer recommending improvements required to bring the streets to meet current design and construction standards must accompany a petition to convert private streets to public streets concurrent with the submittal of the petition. This engineering report shall be at the sole cost and expense of the petitioners. The property must be re-platted to dedicate the streets to the city on the revised final plat.
3. Should the city elect to accept the streets as public, the city may inspect the private streets and assess the lot owners for the expenses needed to repair the streets to current public street maintenance standards. The city may require, at the lot owner's expense, the removal of guardhouses, access control devices, landscaping, or other appurtenances located within the street lot.

## **2.7 Turning Lanes**

---

- A. Turning lanes are provided at intersections to accommodate left and right-turning vehicles. The primary purpose of these turning lanes is to provide storage for the turning vehicles. The secondary purpose is to provide space to decelerate from normal speed to a stopped position in advance of the intersection or to a safe speed for the turn in case a stop is unnecessary.
- B. Left-turn lanes shall be provided on all approaches at existing or proposed intersections when four or six-lane streets cross (as shown on the thoroughfare plan). Left-turn lanes shall also be provided for all divided streets where median openings provide access to streets, alleys, or driveways, when required by the city.
- C. Right-turn/deceleration lanes shall be provided on all approaches at intersections of arterial and collector streets (as shown on the thoroughfare plan). Right-turn/deceleration lanes shall also be provided at driveways to all commercial developments of five acres or more overall development with sites). The City Engineer may, on a case by case basis, waive the requirement for right-turn/deceleration lanes for one or more driveways for tracts of five acres or more and based on a traffic impact analysis demonstrating adequate traffic safety with the projected traffic patterns of the site.
- D. The minimum length of left-turn lanes, right-turn lanes, and deceleration lanes shall be 100 feet stacking and 100 feet transition except at locations specifically identified by the city as needing less than 100 feet.
- E. The owner shall be responsible for the dedication of all rights-of-way and the construction of all turning lanes.

## **2.8 Traffic Impact Analysis**

---

- A. A traffic impact analysis (TIA) is required for any development or redevelopment which generates 100 or more new peak hour trips and/or generates 500 or more vehicle trips per day based on procedures outlined in the latest editions of Institute of Transportation Engineers (ITE) Trip Generation Manual and Trip Generation Handbook or where, in the opinion of the City Engineer, a TIA is required. A TIA may be required for any development or redevelopment which generates between 50 and 100 new peak hour trips. To document the expected trip generation of proposed development, the "Trip Generation Threshold Analysis Worksheet" shall be completed by a Licensed Professional Engineer in the State of Texas with experience in Transportation Engineering and submitted to the City for review. The City will provide a response as to whether a TIA is required or if the TIA requirement is waived. If a TIA is required, the developer shall coordinate the scope of the TIA with the City Engineer. Whenever these regulations require a traffic impact analysis, the following elements shall be included:
  - B. General site description. The traffic impact analysis shall include a detailed description of the

roadway network within one mile of the site, a description of the proposed land uses, the anticipated stages of construction, and the anticipated completion date of the proposed land development. This description, which may be in the form of a map, shall include the following items:

1. All major intersections;
2. All proposed and existing ingress and egress locations;
3. All existing roadway widths and rights-of-way;
4. All existing traffic signals and traffic-control devices; and
5. All existing and proposed public transportation services and facilities within a one-mile radius of the site.

C. Proposed capital improvements. The traffic impact analysis shall identify any changes to the roadway network within one mile of the site, proposed by any governmental agency. This description shall include the above items as well as any proposed construction project that would alter the width and/or alignment of roadways affected by the proposed development.

D. A traffic impact analysis shall include, at a minimum, the following:

1. Identification of the scope of the TIA (analysis scenarios, study area, etc.)
2. Identification of existing geometric conditions and traffic control devices within the study area.
3. Forecast of future non-site related traffic.
4. Trip generation of proposed development (typical weekday AM and PM peak hour trips, average weekday trips, and weekend peak hour trips).
5. Trip distribution and trip assignment assumptions for proposed development trips.
6. Capacity analyses and projected operational levels of service for study area roadways and intersections
7. Identification of any roadways and/or intersections within the study area that are expected to operate at LOS D, E, or F under existing and/or projected traffic conditions.

### 2.8.2 Roadway impact analysis.

---

A. Transportation impacts.

1. Trip generation. The average weekday trip generation rates (trip ends) and the highest average hourly weekday trip generation rate for the proposed use shall be determined based upon the trip generation rates contained in the most recent edition of the ITE Trip Generation Manual.
2. Trip distribution. The distribution of trips to arterial and collector roadways within the study area in conformity with accepted traffic engineering principles, taking into consideration the land use categories of the proposed development; the area from which the proposed development will attract traffic; competing developments (if applicable); the size of the proposed development; development phasing; surrounding land uses, population and employment; and existing traffic conditions identified.
3. Adequacy determination. The roadway network included within the traffic impact analysis shall be considered adequate to serve the proposed development if existing roadways identified as arterials can accommodate the existing service volume, the service volume of the proposed development, and the service volume of approved but unbuilt developments holding valid, unexpired building permits at level of service C.



### 2.8.3 Intersection analysis.

---

A. Level of service analysis. For intersections within the roadway traffic impact analysis area described in subsection (1) of this section, a level of service analysis shall be conducted for one day Tuesday through Thursday on all intersections, including site driveways within one mile of a proposed site. The City may waive analysis of minor intersections within the one-mile radius. The highest average hourly peak volume between 4:00 p.m. and 6:00 p.m. shall also be recorded. The level of service analysis shall take into consideration the lane geometry, turning movement volumes, percentage of trucks, intersection width, number of lanes, signal progression, ratio of signal green time to cycle time (G/C ratio), roadway grades, pedestrian flows, and peak hour factor.

B. Adequacy analysis. The intersections included within the traffic impact analysis shall be considered adequate to serve the proposed development if existing intersections can accommodate the existing service volume, the service volume of the proposed development, and the service volume of approved but unbuilt developments holding valid, unexpired building permits at level of service C.

C. Effect of adequacy determination. If the adequacy determination for roadways and intersections indicates that the proposed development would cause a reduction in the level of service for any roadway or intersection within the study area below the level of service required, the proposed development shall be denied unless the owner agrees to one of the following conditions:

D. The deferral of building permits until the improvements necessary to upgrade the substandard facilities are constructed, as shown in the city's capital improvements program;

E. A reduction in the density or intensity of development;

F. The dedication or construction of facilities needed to achieve the level of service required; or

G. Any combination of techniques identified that would ensure that development will not occur unless the level of service for all roadways and intersections within the traffic impact analysis study are adequate to accommodate the impacts of such development.

## City of Dayton, TX - Trip Generation Threshold Analysis Worksheet

August 2019 Threshold Analysis Worksheet

Submittal Date: \_\_\_\_\_

Development Name: \_\_\_\_\_

Approximate Location: \_\_\_\_\_

### Proposed Land Use and Trip Generation Data for Buildout of Development

*Trips shall be calculated using the most recent version of the ITE Trip Generation Manual*

Land Use Type	Intensity	Units	ITE Code	Equation Used (i.e. Rates or Regression)	Daily Total (Weekday)	AM Peak Hour			PM Peak Hour			Sat Peak Hour				
						In	Out	Total	In	Out	Total	In	Out	Total		
<b>TOTALS:</b>																

**Notes:**

- A Traffic Impact Analysis (TIA) will be required when the development is expected to generate 500 or more vehicle trips per day OR 100 or more new peak hour vehicle trips during a typical weekday.
- The City Engineer may require a TIA at any stage of a development whether it meets this criteria or not if special circumstances exist that may require a TIA.
- If a TIA is needed based on this Threshold Worksheet, the developer shall contact the City Engineer to determine the actual study requirements regarding time periods, study area intersections, etc.
- The use of internal capture trip reduction rates shall not be permitted without the prior approval of the City Engineer.

Threshold Worksheet Completed By:

Name: \_\_\_\_\_

Address: \_\_\_\_\_

Phone: \_\_\_\_\_

seal / signature / date

Trip Generation Threshold Analysis Worksheet shall be completed by a Licensed Professional Engineer in the State of Texas with experience in Transportation Engineering.

**THIS SECTION FOR CITY USE ONLY: Based on this submittal, a TIA is hereby REQUIRED or WAIVED (circle one)**

Name: \_\_\_\_\_ Title: \_\_\_\_\_

Date: \_\_\_\_\_

## 2.9 Street Names and Signs

---

- A. Street names. The Liberty County 911 Addressing Department shall approve all street names.
- B. Street signs. The total cost of street signs and posts shall be furnished to the city by the owner for all intersections within or abutting the subdivision. Such signs shall be of a type approved by the city's designated official and shall be installed per city standards.
- C. Street signs shall be installed per the City's standard details.

## 2.10 Conduit for Fiberoptic Cable

---

- A. Developer will provide fiber optic conduit system including fiber optic cable, conduit, pullboxes, splices, terminations, and testing per City requirements.
- B. Basic Fiber Specifications
  - 1. Backbone cable size: 144/288 count fiber
  - 2. Lateral cable size: 12/24 count fiber
  - 3. Single mode, loose-tube non-armored cable
  - 4. Jacketed central member
  - 5. Outer polyethylene jacket
  - 6. Sequential markings in meters
  - 7. All dielectric
  - 8. Gel-free/dry buffer tubes
  - 9. 12 fibers per buffer tube
  - 10. Color coded buffer tubes based on ANSI/TIA/EIA 598-B Standard Color

### C. Basic Conduit Specifications

- 1. 36-inch minimum depth of cover (to top of conduit)
- 2. 2-inch diameter HDPE smooth wall reel-mounted pipe for underground duct
- 3. Install warning tape at 12-inch or 18-inch depth
- 4. Maximum fill ratio: 50%
- 5. Provide innerduct where appropriate for subdividing duct space
- 6. Place vaults at intersections, and minimum every 500-foot in commercial corridors
- 7. Size vaults appropriately to house underground lid-mounted pedestals and splice enclosures

## PART 3: DRAINAGE

### 3.1 Drainage Design Standards

A. Owners must refer to the most current flood insurance rate maps (FIRM) and flood boundary-floodway maps prepared by FEMA for the city to determine whether their property is within the boundaries of a designated flood hazard area. The city's floodplain administrator is the City Engineer. Plats are reviewed by the City Engineer to determine that the potential for flooding in the area will not increase due to the proposed development, and that the proposed development is sufficiently protected from a 100-year frequency storm runoff from a fully developed upstream watershed. If the development area is within a flood hazard area, construction cannot begin until the owner has received an approved floodplain development permit from the city.

#### 3.1.2 General Requirements

- A. Pipe Material: Storm pipe shall be Reinforced Concrete Pipe
1. Conform circular reinforced concrete pipe to requirements of ASTM C 76, Class III. Conform to rubber gasket joints for sanitary sewers and storm sewers per ASTM C443 and tongue and groove joints for roadside ditch culverts with joints per ASTM C 990.
  2. Conform reinforced concrete arch pipe to requirements of ASTM C 506 for Class A-III. Joints shall conform to ASTM C 443 or tongue & groove joints shall conform to ASTM C 990 with external sealing bands conforming to ASTM C 877. For roadside ditch culverts only, external sealing bands are not required.
- B. Drainage facilities shall be designed and constructed at such locations, size and dimensions to serve the development adequately and the contributing drainage area above the development. The owner shall provide all the necessary easements and rights-of-way required for drainage structures including storm drains and open channels, lined or unlined.
- C. The 100-year frequency storm for fully developed conditions shall be established by the developer. Developer shall study FEMA Zone A designated areas to establish elevations for the reach.
- D. The minimum finished floor elevation for lots impacted by natural creeks shall be a minimum of two feet above the 100-year ultimate water surface elevation.
- E. Storm drainage released from the site will be discharged to a natural watercourse of an adequate size to control the peak runoff expected after development.
- F. The owner shall be responsible for the necessary facilities to provide drainage patterns and drainage controls such that properties within the drainage area, whether upstream or downstream of the development, are not adversely affected by storm drainage from facilities on the development.
- G. Engineering plans that include grass-lined ditch drainage facilities should include the following note: "Maintenance of open drainage ditches is the responsibility of the property owner, not the City."
- H. The requirements set forth herein are considered minimum requirements. The owner and his engineer shall bear the total responsibility for the adequacy of design. The approval of the facilities by the City Engineer in no way relieves the owner of this responsibility.
- I. No person shall deepen, widen, fill, re-route, or change the course or location of any existing ditch, channel, stream, or drainageway, without first submitting engineering plans for approval

by the City Engineer, consistent with the floodplain reclamation and preservation provisions contained in this Section. Such plans shall be prepared by a professional engineer, registered in the state, and experienced in civil engineering.

J. No portion of a lot that is smaller than one acre may be within a floodplain shown on the FEMA flood insurance rate maps.

K. All drainage facilities shall be designed according to the design manual and any official drainage and flood control ordinance or drainage design manual that is in effect or may be adopted by the City Council.

### 3.1.3 Design of Storm Sewer

---

A. Standards. Design of storm sewer systems shall be in accordance with the design manual. Materials and construction shall conform to the standard specifications of the city, and TxDOT, where appropriate. Curbs, inlets, manholes, etc., shall be designed and constructed in accordance with the standard details.

B. Drainage study. A drainage study shall be provided for each development. The study shall be provided to ensure that all upstream and downstream watershed components are accounted for and will not be adversely impacted. The study shall include a predevelopment versus post-development runoff analysis and a stormwater runoff routing analysis designed to predict the post development runoff rate and the downstream drainage system ability to accommodate post development runoff. Comply with requirements of Texas Water Code. Existing and Ultimate conditions for the watershed shall be considered.

C. Accommodation of upstream drainage areas. A culvert or other drainage facility shall in each case be large enough to accommodate potential runoff from its entire upstream drainage area, whether inside or outside the subdivision or development in a fully developed condition without detention facilities. The owner's engineer shall initially determine the necessary size of the facility, based on the provisions of the construction standards and specifications assuming conditions of maximum potential watershed development permitted by the zoning regulations, subject to approval by the City Engineer.

D. Effect on downstream drainage areas. The owner's engineer, subject to approval by the City Engineer, shall study the effect of each development's storm runoff on the existing underground drainage facilities immediately downstream of the development. Where it is determined, existing capacity is not available immediately downstream, the owner's engineer shall design a drainage system, detention facility, or parallel system to mitigate the deficiency. The City may withhold approval of the plat until such mitigation has been provided. If oversize improvements are required, then the city may participate in the cost as prescribed by this chapter.

E. Hydrology. Peak discharges shall be determined by using the Rational Method for watersheds less than 100 acres, or as otherwise approved by the City Engineer. A Unit Hydrograph Method (SCS) shall be used for watersheds larger than 100 acres. Routing methods shall be discussed prior to an analysis being performed. TR-55 shall be used to determine curve numbers and time of concentrations.

F. Time of Concentrations. For undeveloped areas, a minimum inlet time of 10 minutes shall be used. Time of concentrations shall be shown on the drainage area map and calculations shall be provided that validate the time of concentration. Maximum sheet flows shall be 100 feet. Shallow concentrated flows shall be limited until the flow regime becomes channelized. Contours will be used to verify the time of concentration and flow regimes.

G. Detention facilities. Lakes, detention ponds, and retention ponds may be constructed in all

areas provided they are approved by the City Engineer. Private easements shall be provided to ensure protection of these areas for maintenance purposes. Provide access for City to inspect all detention facilities.

H. Alternate facilities. Other innovative drainage concepts will be considered if approved by the City Engineer.

I. Design storm frequency. The storm frequency used for this determination will be according to the facility to be designed as listed below. Emergency overflows, where used, are to be located at sags and T-intersections of streets and designed to prevent erosion and surface water damage. Emergency overflow paths shall be shown on the plans. Emergency overflow paths between houses shall be contained within an easement. Rainfall intensities shall be taken from NOAA Technical Memorandum NWS HYDRO-35 for storm durations of less than 60 minutes, NOAA Technical Paper 40 for storm durations between 60 minutes and less than 24 hours, and NOAA Technical Paper 49 for storm durations of 24 hours or more. Refer to Intensity Duration and Frequency (IDF) Chart.

J. TABLE: DESIGN STORM FREQUENCY

Drainage Facility	Storm Frequency
Drainage ditches located in street right-of-way used in conjunction with County Lanes and Parkway street construction with no freeboard	100 years
Pipe storm sewers with emergency overflow to give a combined capacity of 100-year frequency	25 years
Pipe storm sewer with no emergency overflow	100 years
All open channels with a minimum of 2 feet freeboard above to the top of the bank	100 years
Culverts (pipe or concrete box)	100 years
Bridges, low-point of bridge beams or similar bridge deck supporting structure to be two feet above 100-year storm or highest flood recorded, whichever is greater	100 years

K. Flow in gutter and inlet location. A storm drain conduit shall begin at the point where the depth of flow based on the 100- storm frequency reaches the top of curb. Inlets are then to be located as necessary to remove the flow based on a design storm event and dry lane criteria. Multiple inlets at a single location are permitted with sufficient justification provided and approved by the City Engineer. Where possible, inlets should be placed upstream from an intersection to prevent large amounts of water running through intersection. Water will not be allowed to stack above 6-inches.

L. Inlet Depth: Curb inlets shall be 4.0' or 4.5' deep from top of curb to the flowline of the inlet.

**Dayton, Texas Intensity Duration Frequency (IDF) Curve**  
Design Engineer is responsible for checking this curve against current published information from authorities such as NOAA.

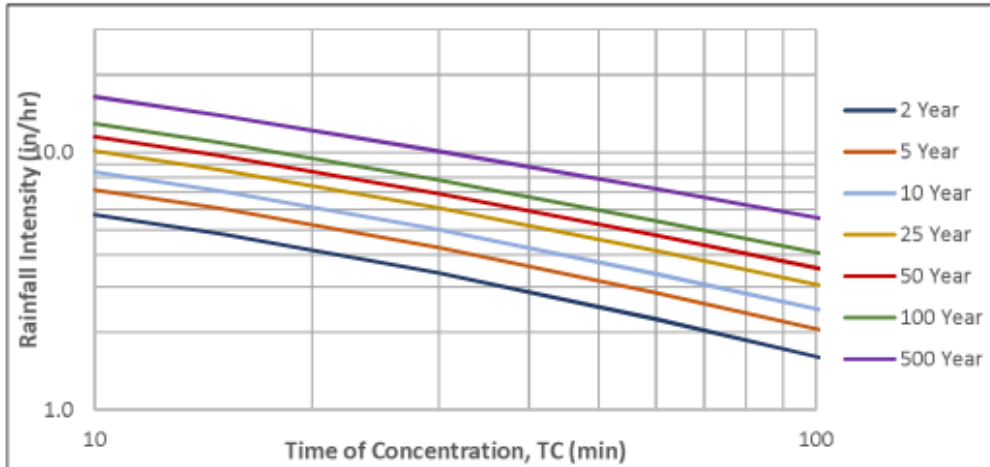

$$\text{Intensity, } i = \frac{b}{(d + TC)^e}$$

Coefficient	50 % AEP	20 % AEP	10 % AEP	4 % AEP	2 % AEP	1 % AEP	0.2 % AEP
	2-Year	5-Year	10-Year	25-Year	50-Year	100-Year	500-Year
<i>Region 3</i>							
<b>e</b>	0.7244	0.6900	0.6623	0.6294	0.6096	0.5797	0.5196
<b>b (in.)</b>	48.35	52.32	54.68	57.79	61.00	60.66	62.17
<b>d (min.)</b>	9.07	7.88	6.96	5.89	5.46	4.44	2.95

*AEP - annual exceedance probability*



M. Inlet sizing. Inlets shall be sized based on the following:

TABLE: INLET SIZING

Street Grade	Length of Inlet Opening for Each cfs of Gutter Flow
Sags	0.6 foot
Less than 4%	1 foot
Greater than 4%	1.5 foot

N. Road, alley, and pipe capacities. Road, alley, and pipe capacities shall be calculated by Manning's formula:

$$Q = \frac{1.486}{n} A R_h^{2/3} S^{1/2}$$

O. Where:

1. Q = the flow in cubic feet per second (cfs)
2. n = the Manning coefficient of roughness (independent of units)
3. R<sub>h</sub> = the hydraulic radius (ft.)
4. S = the slope of the water surface or the linear hydraulic head loss (ft./ft.)

P. Roughness coefficients "n" for storm drains/roadways.

Q. TABLE: ROUGHNESS COEFFICIENT

Materials of Construction	Manning's Coefficient
Monolithic concrete structure	0.015
Concrete pipe	
Good alignment, smooth joints	0.013
Fair alignment, ordinary joints	0.015
Poor alignment, poor joints	0.017
Corrugated metal pipe	
Standard unpaved with or without bituminous coating	0.024
Paved invert, 25% of periphery paved	0.021
All roadways	0.020



R. Recommended maximum velocity. The following velocities may not be exceeded without permission of the City Engineer:

S. TABLE: MAXIMUM VELOCITIES

Type of Conduit	Maximum Velocity
Culverts	10 fps
Inlet laterals	10 fps
Storm sewers	10 fps

---

## 3.2 Spread of Stormwater

---

### 3.2.1 Street capacity

---

- A. The use of the street for carrying stormwater shall be limited to the following:
1. Spread of water, 25-year storm frequency.
  2. Major collector or arterial: one traffic lane to remain clear.
  3. Residential streets with curbs and gutters: six-inch depth of flow at curb or no lanes completely clear.
  4. Alleys: contained within the paved surface.
  5. Spread of water, 100-year storm frequency.
- B. For streets and roadways without curbs, the spread of water shall be based on a 100-year storm frequency. All stormwater must be contained within the right-of-way. The depth of flow shall not exceed the roadway crown elevation.
- C. Notwithstanding the requirements above, all stormwater in the 100-year storm frequency shall be contained within the street or alley right-of-way or with in the drainage easement. The water depth shall not be greater than one inch over any curb.

### 3.2.2 Open channels and roadway ditches

---

- A. Open channels may be used to convey stormwater only in the following applications:
1. Where the size of the conduit required to convey the flow exceeds a 72-inch storm sewer laid on the same grade as the proposed channel;
  2. Where open channels serve as roadway ditches located within standard street rights-of-way and where the depth of flow does not exceed three feet in a 100-year storm; or
  3. Where open channels are used to convey stormwater between adjacent lots provided the 100-year flow rate does not exceed five cfs.
- B. The use of existing channels in their natural condition is required. Grading or channelizing an existing wooded natural channel is permitted only with special permission.
- C. In each case, an adequate drainage easement shall be dedicated to meet ultimate flow requirements and totally encompass the 100-year flood event.
- D. These requirements may be modified if indicated in the geotechnical report.

### 3.2.3 Open channel design and construction requirements.

---

- A. For channel sections, the maximum side slope permitted is 4:1 with geotechnical verification of the soil materials and slope stability.
- B. All open channels except those used to convey stormwater between lots shall be constructed with a reinforced concrete low flow pilot channel.
- C. Low flow pilot channels are required for roadway ditches. City Engineer may waive this requirement. Where roadway ditches are used in new subdivisions, the pilot channels be constructed by the owner and shall be continuous throughout the development. Where existing roadway ditches are within or adjacent to a new development, low flow pilot channels shall be constructed in the existing ditch as directed by the City Engineer. Low flow pilot channels for roadway ditches shall be four feet wide with a six-inch invert and constructed as specified for sidewalks.
- D. Concrete lined channel sections and riprap lined channel sections are discouraged and may

be used only with the permission of the City Engineer.

E. Maximum allowable velocity is six feet per second (fps).

F. These requirements may be modified if indicated in the geotechnical report.

### 3.2.4 Dedication of drainage and floodplain easements

---

A. General requirements. When a subdivision or development is traversed by a watercourse, drainageway, channel, or stream, there shall be provided a private or public stormwater or drainage easement conforming substantially to the line of such watercourse, and of such width and construction as will be adequate for the purpose. Wherever possible, it is desirable that the drainage be maintained by an open channel with landscaped banks and adequate width for maximum potential volume of flow. Acceptable types of easements include:

B. Drainage easements are required for both on-site and off-site public storm drains and for improved channels designed according to current city standards.

C. Floodplain easements shall be provided on-site along natural or improved drainageways. Floodplain easements shall encompass the entire area of inundation due to the 100-year storm using fully developed conditions, plus a ten-foot buffer on either side. The buffer shall be part of the floodplain easement itself and not a separate easement. Floodplain easements are not maintained by the city. No construction shall be allowed within a floodplain easement without the written approval of the city, and then only after detailed engineering plans and studies show that no flooding will result, and that no obstruction to the natural flow of water will result. In certain circumstances where detention is in place or a master drainage plan has been adopted, a development will dedicate easements for specific requirements defined by the watershed plan.

D. Temporary drainage easements are required off-site for temporary channels when future off-site development is anticipated to be enclosed underground or follows an altered alignment. Temporary drainage easements will not be maintained by the city and will not terminate until permanent drainage improvements meeting city standards are installed and accepted. Temporary drainage easements will require written approval from the city.

E. Access easements. The owner must provide sufficient access on each side of and parallel to creeks or drainageways for maintenance purposes. The access shall be above the base flood elevation and accessible to vehicles and equipment. Access must also be provided at a maximum 1,200-foot spacing along streets or alleys. The location and size of the access easement shall be determined by the City Engineer. The maximum width of the access easement shall be 15 feet. Permanent monuments, the type, and locations of which to be determined by the City Engineer, shall be placed along the boundaries of the access easement and private property. This access easement shall be included in the dedication requirements of this section. The access points shall be appropriately designed to restrict access by the public (including motorcycles).

### 3.3 Public and private easements

---

A. The easements described herein may be either public or private easements. The city shall determine whether easements will be public or private easements.

B. Public easements and improvements therein will be maintained by the city.

C. Private easements and improvements shall be maintained by the owner or through a property owner's association. The city shall have the right but not the obligation to maintain private easements to protect the public.

D. All amenity lakes, retention basins, detention basins, and drainageways shall be maintained

by the property owner or property owner's association.

E. Maintenance shall include mowing, removal of silt and algae, control of weeds, removal of trash, and maintenance of equipment and other improvements. Grass and vegetation cover shall be maintained in a healthy condition at all times. Any bare ground shall immediately be seeded or covered with sod grass or other acceptable vegetation. All erosional rivulets or other erosion damage shall be immediately repaired. Erosion control devices including erosion control matting shall be installed over any bare ground. Failure to maintain amenity lakes, retention basins, detention basins, and drainageways is a violation of this chapter.

### 3.3.2 Drainage easements

---

A. Where topography or other conditions are such as to make impractical the inclusion of drainage facilities within street rights-of-way, perpetual, unobstructed easements at least ten feet in width, depending on slopes, for drainage facilities shall be provided across property outside the street lines and with satisfactory access to the street. Easements shall be indicated on the plat. Drainage easements shall extend from the street to a natural watercourse or to other drainage facilities.

B. When a proposed drainage system will carry water across private land outside the subdivision or development, appropriate drainage easements must be secured by the owner.

C. Drainage easements shall be provided where any type of drainage system; including swales are used to convey stormwater across any lot or tract in the development from an adjacent lot or tract whether or not the lot or tract is within the development or off-site.

D. Minimum easement requirements for storm sewer pipe are shown in the table and shall be as follows:

1. The outside face of the proposed storm drain line shall be placed five feet off either edge of the storm drain easement. The proposed centerline of overflow swales shall normally coincide with the centerline of the easement.
2. For pipe sizes 39 inches through 54 inches, a minimum of five additional feet shall be dedicated when shared with utilities.
3. Box culverts shall have an easement width equal to the width of the box plus 20 additional feet. The edge of the box shall be located five feet from either edge of the easement.
4. Drainage easements will generally extend at least 25 feet past an outfall headwall to provide an area for maintenance operations. Drainage easements along a required outfall channel or ditch shall be provided until the flowline reaches an acceptable outfall. The minimum storm drain shall not be on property line, except where a variance has been granted.

E. TABLE: CLOSED CONDUIT EASEMENTS

Pipe Size	Minimum Easement Width Required
39 inches and under	15 feet
42 inches through 54 inches	20 feet
60 inches through 66 inches	25 feet
72 inches through 102 inches	30 feet

F. Any parallel utility easements must be separate and outside of drainage easements for channels. Drainage and utility easements can be combined for underground storm drains, subject to the easement width requirements.

G. Drainage easements shall include a minimum five-foot buffer on both sides beyond actual top of improved channels.

H. Retaining walls are not permitted within or adjacent to a drainage easement in a residential area in order to reduce the easement width. Retaining walls adjacent to the channel are allowed in nonresidential areas only if the property owner provides an agreement for private maintenance.

I. Lined channels shall have drainage easements dedicated to meet the requirements of the width of the channel, the one-foot freeboard, any perimeter fencing, and any underground tie-backs or anchors.

J. Easements for detention and retention ponds shall be determined by the city and generally shall encompass the detention or retention pond to the top of slope for excavations or to the outside toe of slope for any embankments associated with such ponds. Provide access ramps.

K. Erosion setbacks may be required within the dedicated easement at the City Engineer's discretion.

3.3.3 Floodplain easements

A. All areas within any subdivision located in the 100-year floodplain of any river, creek, or tributary stream shall be dedicated as a drainage and utility easement. The form and wording of the easement shall be approved by the City Engineer.

B. Natural creeks shall have a dedicated floodplain easement of ten feet adjacent to the water surface elevation of a 100-year ultimate frequency storm.

**3.4 Private Ponds**

A. An owner may impound stormwater by excavation, filling or construction of a dam within a property, thereby creating a lake, pond, or lagoon as a part of the development of that property, provided:

B. An engineering plan for such construction, accompanied by complete drainage design information, prepared by a registered professional engineer, shall have been approved by the City Engineer;

C. The owner agrees to retain, under private ownership, the lake, pond, or lagoon constructed,

and to assume full responsibility for the protection of the general public from any health or safety hazards related to the lake, pond, or lagoon constructed;

- D. The owner agrees to assume full responsibility for the maintenance of the lake, pond, or lagoon constructed;
- E. The obligations herein run with the land, resulting in a continuing obligation of the owner of such land;
- F. The requirements of the Texas Water Code, pertaining to impoundment of surface water are complied with, including, but not limited to, the design construction and safety of the impounding structure; and
- G. On any existing structure, the owner furnishes the city with a study proposed by a professional engineer for the city's approval.
- H. A permit for the construction of a private pond is required before construction may begin. A permit application shall be filed with the City Engineer on forms provided by the city. The application shall include drawings, hydraulic data, and any other relevant information required to evaluate the application. The City Engineer shall review and approve the application if it meets all city standards.
- I. Exemptions. The following impoundments are exempt from the requirements of this section:
  - 1. Swimming pools constructed under a specific permit.
  - 2. Impoundments of less than 0.5 acre-feet of water at the maximum capacity level.

### **3.5 Floodplain Reclamation**

---

#### **3.5.1 Purpose**

---

- A. The purpose of this section is to specify standards and procedures for reclamation of floodplain land consistent with the city's objectives to maintain quality development, preserve natural areas and trees, ensure the safety and welfare of its residents with respect to flood hazards, and to implement in part the city's comprehensive plan policies relating to environmental quality and open space.
- B. It is the intent of the City Council that the requirements of this section be consistent with requirements contained in Article 14.400 of the Unified Development Code (the flood damage prevention regulations codified in Sections 14.401 and 14.402), and with federal requirements pertaining to the Federal Emergency Management Agency's authority concerning flood hazards and the Corps of Engineer's jurisdiction over waters of the United States, including wetlands pursuant to section 404 of the Clean Water Act.
- C. It is the further intent of this section that development on floodplain land be integrated with the city's standards for providing open space in planned residential and other developments.
- D. Land located within the floodplain may be reclaimed for purposes of development only in accordance with the standards and procedures set forth in this section.

#### **3.5.2 Applicability**

---

- A. A person shall comply with the requirements of this section for floodplain areas before making substantial improvements to or increasing the outside dimensions of an existing structure or developing land within the floodplain of a creek or stream where:
  - 1. The creek or stream has a contributing drainage area of 100 acres or more; or

2. The contributing drainage area of the stream or creek is not wholly owned by the owner or person filling or modifying the stream or floodplain.
- B. The provisions of this chapter shall apply whether or not the land has been formally designated as a floodplain. Floodplain areas shall also include all areas inundated by the design flood and shown as areas of special flood hazard on FEMA flood insurance study maps. Filling a floodplain is prohibited unless such filling activities have been approved by the City Council.
- C. The following activities constitute reclamation subject to this section:
1. New construction of a building or structure;
  2. Improvements to existing homes or structures in a floodplain if the improvements result in the increase of the overall outside dimensions of the structures or homes;
  3. Filling in a floodplain;
  4. Channelization, impoundment, realignment, deepening, or other modification of a drainageway;
  5. Construction of utilities or roads;
  6. Removal of significant tree stands;
  7. Site preparation, including grading or removal of topsoil.
- D. Exemptions. The following activities are exempt from the requirements of this section: subsequent development applications which are subject to and consistent with the following types of applications, which approved or conditionally approved prior to the effective date of the ordinance from which this chapter is derived, to the extent that the reclamation proposed in the subsequent application was shown on the prior approved application: fills that cover less than one-tenth acre and the fill does not affect drainage or water surface elevations adjacent property. In order to qualify for this exemption, the area of fill must not be placed adjacent to previously placed fill, regardless of the date of placement.
- E. Filling in drainage basins that:
1. Have an area of less than 100 acres; and
  2. The entire drainage basin is wholly owned by the owner.
- F. Fills placed for the sole purpose of constructing driveways to private residences. All driveway culverts shall be designed to convey the 100-year ultimate design flow without overtopping the driveway.
- G. Fill of temporary drainage control basins used as best management practices (BMPs) for control of sediment in runoff from construction activities, if the fill is placed so that the original contours of the disturbed site are restored, and no fill is placed in jurisdictional waters of the United States.
- H. Staged procedures. Authorization to reclaim floodplain land shall be made in two stages:
- I. Reclamation concept plan. Approval of a reclamation concept plan by the City Council, which authorizes the owner to submit an application for a reclamation permit, subject to any approval required from federal agencies exercising jurisdiction over the proposed reclamation.
- J. Reclamation permit. Approval of a reclamation permit by the City Engineer, which shall be consistent with the reclamation concept plan and which authorizes the owner to commence alteration of the floodplain in accordance with the conditions of the reclamation permit. Prior to floodplain alteration, the owner also shall obtain a development permit addressing flood protection criteria, pertaining to flood damage prevention (Article 14.400 of the unified development code), which may be approved simultaneous with approval of the reclamation



permit.

### 3.5.3 Reclamation Concept Plan

---

A. Purpose. The purpose of the reclamation concept plan is to provide an overview of the impacts of proposed floodplain development involving the alteration of the 100-year ultimate floodplain, and to provide a basis for determining whether the city should authorize all or a part of the proposed reclamation of the floodplain. If the floodplain reclamation is part of a subdivision or development, the reclamation concept plan shall be filed with the preliminary plat.

B. Application requirements. The application for approval of a reclamation concept plan shall be accompanied by the following:

1. A general description of the development project of which the reclamation is a part, identifying proposed land uses in relation to the floodplain, and the density or intensity of such uses. An application for establishment of a planned development district or for approval of a preliminary plat may be used to satisfy this requirement.
2. The nature, location, extent, dimensions, and elevations of the project, including existing or proposed structures, in relation to mean sea level of the floodplain area to be reclaimed.
3. The location of fill, storage of materials, or drainage facilities, and their elevations in relation to mean sea level.
4. A general description of upstream and downstream conditions, including the extent of the development in the drainage basin and properties that may be affected by reclamation.
5. Identification of any off-site facilities or conditions that either may affect on-site conditions or be affected by on-site conditions.
6. A general description of the amount and nature of the materials to be removed or to be used as fill within the floodplain for the project.

C. A proposed reclamation concept plan prepared on a 24-inch by 36-inch sheet at a scale of between one-inch equals 20 feet and one-inch equals 200 feet that includes the following:

1. General project description;
2. Vicinity map;
3. Area to be altered or reclaimed, clearly distinguishing flood fringe and floodway areas;
4. Tree stands and other natural features of the site;
5. Cultural or historic features;
6. Proposed landscaping and vegetation plan for reclaimed and other affected areas. The plan should show the general nature and extent of existing vegetation on the tract, the location of trees six-inch and larger in diameter, the areas which will be preserved, altered, or removed as a result of the proposed alterations. Locations and construction details should be provided, showing how trees will be preserved in areas which will be altered by filling or paving within the drip line of those trees. The owner should also submit plans showing location, type, and size of new plant materials and other landscape features planned for altered floodplain areas;
7. Proposed mitigation plan. If a section 404 application has been submitted, the mitigation plan should reflect the contents of the section 404 mitigation plan;
8. Professional certification of the status of any jurisdictional wetlands or other waters of the United States, as defined by the U.S. Army Corps of Engineers pursuant to requirements of section 404 of the Clean Water Act, for the floodplain areas to be reclaimed. If jurisdictional waters exist on the property to be reclaimed, the owner shall provide the city with a copy of



all reports, studies, plans, and other data that are submitted to the U.S. Army Corps of Engineers in conjunction with an application for approval of a section 404 permit.

#### 3.5.4 Procedures

---

- A. City Engineer evaluation. The City Engineer shall evaluate the information and data submitted with the application for reclamation concept plan and shall make his recommendation to the City Council concerning the application.
- B. Public notice and hearing. Following receipt of the City Engineer's recommendation concerning the reclamation concept plan, the City Council shall give notice and conduct a public hearing.
- C. City Council decision. Following public hearing on the application for a reclamation concept plan, the City Council may approve, conditionally approve, or disapprove the plan.
- D. Approval criteria. In taking action on the reclamation concept plan, the council shall consider the following criteria:
1. Whether the reclamation plan is consistent with the city's comprehensive plan and any proposed zoning classifications for the subject property;
  2. Whether the plan is compatible with zoning and use of adjacent property and particularly land downstream from the proposed reclamation;
  3. Whether the proposal adversely affects the following community resources:
    - Wetlands and/or waters of the United States;
    - Vegetated buffer next to rivers, streams, lakes or other open waters;
    - Critical wildlife habitat, particularly that for any endangered or threatened species and/or migratory birds;
    - Significant tree stands;
    - Scenic corridors or vistas as viewed from arterial or collector thoroughfares or other viewpoints accessible to the public;
    - Cultural resources, including prehistoric and historic archeological sites, and historic structures; and
    - Public open space.
  4. Whether any adverse effects have been appropriately mitigated.
  5. The council approval of the reclamation concept plan shall not constitute the city's guarantee of the engineering information provided by the owner nor shall it constitute the city's approval of any improvements, filling, or alteration of the area contained in the reclamation concept plan.
- E. Coordination with other agencies. If wetlands or waters of the United States protected under section 404 of the Clean Water Act are determined to exist on the land to be reclaimed, the city's action on the reclamation concept plan shall be deferred until such time as the owner demonstrates proof of compliance with all federal regulations pertaining to the protection and mitigation of such areas.

#### 3.5.5 Conditions and effect

---

- A. The City Council may impose such conditions on the approval of a reclamation concept plan as are reasonably necessary to ensure that reclamation of the floodplain is consistent with the goals of the city's comprehensive plan and complies with the zoning regulations.

B. The City Council expressly may require as a condition of approval that adverse effects be offset through a mitigation plan and that such plan be incorporated within the reclamation concept plan. The mitigation plan may provide for restoration, creation, enhancement, or preservation of aquatic habitats to ensure that activities result in minimal adverse effects to the aquatic environment. The mitigation plan may but need not be the same as any mitigation plan required for obtaining a section 404 permit.

C. Approval or conditional approval of a reclamation concept plan entitles the owner to apply for a reclamation permit for the areas addressed in the reclamation concept plan.

### 3.5.6 Reclamation Permit

---

A. Purpose. The purpose of the reclamation permit is to ensure that conditions of the reclamation concept plan are fulfilled and that standards in this chapter are met prior to development on land in a floodplain subject to this section.

B. Application requirements. The application for approval of a reclamation permit shall be accompanied by the following reports and data. All mapped information shall be of suitable scale and topographic definition to provide reasonable accuracy. If the floodplain reclamation is part of a subdivision or development, the reclamation permit shall be filed with the final plat.

C. Engineering report. An engineering report shall be submitted consisting of at least:

1. Project description.

2. Description of the hydrologic and/or hydraulic analyses used, including method used to determine historic rainfall and stream data, soils reports used to determine erosive velocity values, and discharges and water surface elevations for both the design and base floods.

3. Vicinity map.

4. Evaluation of the floodway and floodplain limits for the design flood. Included are both the regulatory floodway and floodplain as established by FEMA but also any other floodplain or floodway as described in this chapter.

5. If hydraulic analyses are being submitted, then a table of values for existing and proposed water surface elevations and velocities must be included.

6. Documentation that the principle of equal conveyance has been achieved.

7. Copies of computer input and output data for existing and proposed conditions for both the base flood and design flood discharges.

8. Evaluation of existing and proposed valley storage.

9. Engineering drawings consisting of water surface profile, including channel flow line, existing and proposed water surface elevations, recorded high water marks, and location and number designation of cross sections.

D. Engineering drawings showing plan view on 24-inch by 36-inch paper, including:

1. Scale and north arrow;

2. Title block;

3. Boundary lines and nearest street intersections;

4. Existing and proposed contours;

5. Existing and proposed floodplain and floodway limits;

6. Area to be removed from the floodplain or area to be altered;

7. Top and toe of fill and/or side slopes and the numerical slope of the fill and/or side slopes labeled;

8. Location of all other associated improvements or alterations to the creek and/or floodplain, such as check dams, swales, channel modifications, etc.;
  9. Location of cross sections;
  10. Location of all existing and proposed easements and dedications;
  11. Site vicinity map;
  12. Plots of cross sections, including:
  13. Scale;
  14. Title block;
  15. Existing and proposed ground elevations;
  16. Cut and/or fill areas labeled;
  17. Limits of and numerical values for existing and proposed "n" values;
  18. Equal conveyance removed from both sides;
  19. Erosion control plan for cut and fill slopes; and
  20. Restoration plan for excavated areas.
- E. Flood hazard information. Developments which impact designated FEMA floodplains in the city will be required to submit the following additional data:
1. A written description of the scope of the proposed project and the methodology used to analyze the project's effects.
  2. Hydraulic backwater models of the 10-, 50-, 100-, and 500-year floods for the following:
    - Existing conditions with drainage basin fully developed at maximum density allowed by the city's zoning ordinance and the zoning ordinances of other cities within the drainage basin.
    - Proposed conditions with fully developed drainage basin.
    - Existing conditions with drainage basin fully developed at maximum density allowed by the city's zoning ordinance and the zoning ordinances of other cities within the drainage basin.
    - Proposed conditions with fully developed drainage basin.
  3. Certification that the project meets the requirements of the 44 Code of Federal Regulations (CFR) 60.3(d)(2).
  4. If an existing nonresidential structure is proposed for floodproofing, then a certificate sealed by a licensed professional engineer in the state shall be submitted stating that all of the floodproofing criteria listed in Sections 14.401 and 14.402 of the Unified Development Code, pertaining to flood damage prevention (Article 14.400), will be met.
  5. Proof that legal notices have been sent to all affected property owners when alterations in the regulatory floodway would cause any rise in the 100-year FIS water surface elevation, and that public notices have been published pursuant to FEMA rules.
- F. Procedures. Upon receiving a complete application for a reclamation permit, the City Engineer shall evaluate whether the application should be approved. In evaluating hydraulic models submitted with the application, the City Engineer shall apply the following conventions.
- G. The hydraulic parameters, such as bridge loss coefficients, "n" values, etc., used in the effective FIS models may only be changed where obvious errors or changes have taken place and must be documented.

1. The computed water surface elevation profiles must converge with the existing profiles upstream and downstream of the project.
2. All items must be labeled for easy cross-referencing to the hydraulic model and summary data.

H. Approval criteria and decision. The City Engineer shall determine whether to approve, conditionally approve, or deny the application based upon whether:

1. The reclamation permit conforms to the applicable reclamation concept plan and any attached conditions; and
2. The permit complies with the standards in this section.

#### 3.5.7 Effect.

---

A. Approval of a reclamation permit entitles the owner to commence alterations in the floodplain areas, as authorized in the permit except where developments impact designated FEMA floodplains.

B. For developments which impact designated FEMA floodplains Conditional Letter of Map Revision (CLOMR) shall be filed and approved by FEMA before floodplains can be filled. Filing a Letter of Map Amendment (LOMA) will not be acceptable.

C. The cost of preparing and filing the CLOMR shall be borne by the owner.

#### 3.5.8 Post Permit Procedures.

---

A. Upon completion of the proposed project, as-built plans, certified by a registered professional engineer, shall be submitted to the City Engineer.

B. Permits may be revoked by city if, upon periodic inspection, it is determined that the work is not progressing in accordance with specifications of the approved plan and permit.

C. Owners adjacent to the designated floodplain, other existing creeks, swales or ditches or other flood prone areas as designated by the floodplain administrator shall complete an elevation certificate prior to issuance of a certificate of occupancy by the city.

D. For developments which impact designated FEMA floodplains a letter of map revision (LOMR) shall be filed and approved by FEMA before the final plat is filed.

E. The cost of preparing and filing the LOMR shall be borne by the owner.

#### 3.5.9 Reclamation Standards.

---

A. Preservation of natural features. No wetlands or other significant natural features shall be reclaimed within floodplain areas unless authorized under a mitigation plan approved under this section, and appropriate conditions shall be established to protect such areas from adverse impact during and after reclamation and development of adjacent land.

B. Floodplain easements. Appropriate drainage and flood maintenance easements shall be dedicated as private or public easements as determined by the city prior to approval of a reclamation permit on all floodplain land remaining following reclamation authorized under the approved reclamation concept plan.

C. Buffers. A vegetated buffer area at least 50 feet wide along each bank of a stream and 50 feet wide around the perimeter of a lake or other open water body shall be provided, unless otherwise approved in a mitigation plan. A vegetated buffer may be established by maintaining an existing vegetated area or planting native trees, shrubs, and herbaceous plants on land next to open waters. Grasses shall be selected from those set forth in this section.

D. Water surface elevation. Alterations of the floodplain shall result in no increase in the 100-year water surface elevation on other properties measured under fully developed watershed conditions. No alteration of the floodplain will be permitted which could result in any degree of increased flooding to other properties, either adjacent, upstream, or downstream.

E. Stream velocity. Alterations of the floodplain shall not create an erosive water velocity on site or off site. The mean velocity of stream flow at the site after fill shall be no greater than the mean velocity of the stream flow under existing conditions. No alteration to the floodplain will be permitted which would increase velocities of floodwaters to the extent that significant erosion of floodplain soils will occur either on the subject property or on other properties whether adjacent, upstream, or downstream. Mean channel velocities that exceed six feet per second are considered to be erosive.

F. Valley storage. The storage capacity of creeks and drainageways ("valley storage") by development in the flood fringe area shall not be reduced except as follows:

1. There shall be no reduction in valley storage within any floodplain as shown on the FEMA flood insurance maps.
2. Replacement of valley storage lost as a result of fill activities shall be provided by excavation of off-channel lakes, ponds, or wetland areas within the proposed development boundaries or immediate vicinity.
3. Conveyance. Alterations of the floodplain shall be permitted only so as to achieve equal conveyance (i.e., change in the capacity to carry a particular volume of water per unit of time) on both sides of the natural channel.
4. Under equal conveyance, if the city allows a change in the flood carrying capacity (capacity to carry a particular volume of water per unit of time) on one side of the creek due to a proposed alteration of the floodplain, it must also allow an equal change to the owner on the other side, unless the owner owns both sides of the floodplain along the entire reach of the planned reclamation.
5. The combined change in flood carrying capacity, due to the proposed alteration, plus corresponding alteration to the other side of the creek, may not cause either an increase in flood elevation or an erosive velocity, or violate the other criteria.
6. Conveyance shall be mathematically expressed as:

$$K_D = \frac{1.486}{n} A R^{2/3}$$

G. Where:

H. "n" is the Manning's friction factor; "A" is the cross-sectional area; and "R" is the hydraulic radius.

1. Toe of fill alignment. The toe of any fill slope shall parallel the natural channel to prevent an unbalancing of stream flow in the altered floodplain.
2. Side slopes.
3. To ensure maximum accessibility to the floodplain for maintenance and other purposes, and to lessen the probability of slope erosion during periods of high water, maximum slopes of filled area shall not exceed four feet horizontal to one foot vertical.
4. Retention blankets must be installed on all fill slopes.

5. Rock gabion construction, decorative stone faced reinforced concrete rip-rap or an approved equal erosion protection measure is required on slopes steeper than 4:1. A geotechnical study shall be required.
6. Vertical walls, terracing and other slope treatments will be considered only as (i) part of a landscaping plan submission, and (ii) if no unbalancing of stream flow results. Walls shall not be located within the floodplain.
7. Erosion control. Soil erosion and sedimentation from the area to be reclaimed shall be minimized during and after fill operations consistent with the approved erosion control plan. Soil areas exposed by grading, and length of time of exposure shall be minimized. Existing vegetation shall be retained and protected wherever feasible. Disturbed areas shall have vegetation re-established as quickly as possible. Erosion control structures (e.g., drop structures, sediment ponds, etc.) shall be utilized where necessary for effective erosion control, but shall also be designed to blend in with the natural appearance of the floodplain.
8. Topsoil preservation. Topsoil shall be preserved in all floodplain areas that are reclaimed. Before any excavation or fill operation is begun, the topsoil (not less than six inches of the surface soils) from the area to be excavated or filled shall be stripped and stockpiled. Upon completion of the fill or excavation, at least six inches of top soil shall be placed on all surfaces of the fill or excavation.

### **3.6 Erosion and Sediment Control**

---

- A. During the construction process, soil is highly vulnerable to erosion by wind and water. Eroded soil endangers water resources by reducing water quality and causing the siltation of aquatic habitat for fish and other desirable species. Eroded soil also necessitates repair of sewers and ditches and the dredging of lakes. In addition, clearing and grading during construction cause the loss of native vegetation necessary for terrestrial and aquatic habitat.
- B. As a result, the purpose of this local regulation is to safeguard persons, protect property, and prevent damage to the environment in the city. This chapter will also promote the public welfare by guiding, regulating, and controlling the design, construction, use, and maintenance of any development or other activity that disturbs or breaks the topsoil or results in the movement of earth on land in the city.
- C. An erosion control plan or Storm Water Pollution Plan (SWPPP) shall be provided with each construction plan submitted for review by the City Engineer. Each erosion control plan shall clearly identify all erosion and sediment control measures to be installed and maintained throughout the duration of the project. The erosion control plan or SWPPP shall meet the requirements outlined in the most recent version of the Unified Development Code section for Silt and Erosion Control (Section 14.302.2 General Improvement Standards).

### **3.7 Grading Permit**

---

- A. A grading permit is required for any construction activity or project where it:
  1. Disturbs more than 2,500 square feet of land;
  2. Blocks existing drainage patterns; or
  3. Removes or adds more than 18 inches of soil.
- B. No person shall be granted a grading permit for land-disturbing activity that would require the uncovering of 10,000 or more square feet without the approval of a grading plan by the City Engineer and approval of an erosion and sediment control plan by the designated official.
- C. No person shall be granted a grading permit for land-disturbing activity that would require the uncovering of 43,560 or more square feet without the approval by the City Engineer of a



grading plan and by the designated official of an erosion and sediment control plan and a stormwater pollution prevention plan.

D. No grading permit is required for the following activities:

1. Any emergency activity that is immediately necessary for the protection of life, property, or natural resources.
2. Existing nursery and agricultural operations conducted as a permitted main or accessory use.
3. Installation of pipelines, cables or other similar utilities where the width of the area being disturbed is less than four feet.

E. Each application shall bear the name and address of the owner or owner of the site and of any consulting firm retained by the owner together with the name of the owner's principal contact at such firm and shall be accompanied by a filing fee.

F. Each application for land-disturbing activity that would require the uncovering of 10,000 or more square feet shall include a statement that any land clearing, construction, or development involving the movement of earth shall be in accordance with the erosion and sediment control plan. For grading permits for areas one acre and larger the statement shall include a statement that an erosion and sediment control contractor shall be on site on all days when construction or grading activity takes place.

G. For land-disturbing activity that would require the uncovering of 10,000 or more square feet, the owner will be required to file with the city a maintenance bond, letter of credit, or other improvement security in an amount deemed sufficient by the designated official to cover all costs of improvements, landscaping, maintenance of improvements, engineering and inspection costs, and the cost of failure or repair of improvements installed on the site for a period of two years from the date the site grading is completed and final erosion and sedimentation control measures have been constructed or installed.

### **3.8 Stormwater Pollution Prevention Plan**

---

A. A stormwater pollution prevention plan shall be prepared and submitted for any land-disturbing activity that would require the uncovering of 43,560 square feet or more. The SWPPP shall be prepared and monitored by a certified professional in erosion and sediment control, qualified licensed professional engineer, or qualified landscape architect.

B. The contents of the SWPPP shall meet requirements of TCEQ.

C. The completed plan shall be submitted for review and approval to the designated official.

D. Copies of all notices and reports required by TCEQ shall be filed with the designated official.

E. Design and Construction Requirements

1. Grading, erosion control practices, sediment control practices, and waterway crossings shall be adequate to prevent transportation of sediment from the site to the satisfaction of the designated official. Cut and fill slopes shall be no greater than 4:1, except as approved by the designated official to meet other community or environmental objectives.
2. Clearing and grading of natural resources, such as wooded areas and wetlands, shall not be permitted, except when in compliance with all other chapters of this Code of Ordinances. Clearing techniques that retain natural vegetation and drainage patterns shall be used to the satisfaction of the designated official.
3. Clearing, except that necessary to establish sediment control devices, shall not begin until all sediment control devices have been installed and have been stabilized.



4. Phasing shall be required on all sites disturbing greater than 30 acres, with the size of each phase to be established at plan review and as approved by the designated official.
  5. At least six inches of topsoil shall be removed from the areas to be excavated or filled and stored for use as final cover for the graded area.
- F. Erosion control requirements shall include the following:
1. Soil stabilization shall be completed within five days of clearing or inactivity in construction.
  2. If seeding or another vegetative erosion control method is used, it shall become established within two weeks or the designated official may require the site to be reseeded or a nonvegetative option employed.
  3. Soil stockpiles must be stabilized or covered at the end of each workday.
  4. The entire site must be stabilized, using a heavy mulch layer or another method that does not require germination to control erosion, at the close of construction.
  5. Techniques shall be employed to prevent the blowing of dust or sediment from the site.
  6. Techniques that divert upland runoff past disturbed slopes shall be employed.
- G. Sediment controls requirements shall include:
1. Settling basins, sediment traps, or tanks and perimeter controls;
  2. Settling basins that are designed in a manner that allows adaptation to provide long-term stormwater management, if required by the designated official; and
  3. Protection for adjacent properties by the use of a vegetated buffer strip in combination with perimeter controls.
- H. Waterway and watercourse protection requirements shall include:
1. A temporary stream crossing installed and approved by the designated official if a wet watercourse will be crossed regularly during construction;
  2. Stabilization of the watercourse channel before, during, and after any in-channel work;
  3. Stabilization adequate to prevent erosion located at the outlets of all pipes and paved channels.
- I. Construction site access requirements shall include:
1. A temporary access road provided at all sites; and
  2. Other measures required by the designated official in order to ensure that sediment is not tracked onto public streets by construction vehicles or washed into storm drains.
- J. Revegetation of and placement of permanent erosion control measures on the completed graded area are required and shall include the following:
1. Placing six inches of top soil on top of the completed graded area. Topsoil shall be placed on all graded areas within seven days of the completion of any graded area larger than 1,000 square feet.
  2. Establishing grass cover. The graded areas shall be seeded according to item 164 of the state department of transportation Standard Specifications for Construction and Maintenance of Highways, Streets, and Bridges (TxDOT specifications) with the seed mix and application rates as specified therein for clay soils in the Dallas area (district 18). Seed mixes shall be selected according to the date of the seeding operation. If "temporary seeding" is used, the graded areas shall be subsequently reseeded with a "permanent mix." The graded areas shall be seeded within seven days of the placement of topsoil.
  3. Guaranteed grass coverage.

4. If, after eight weeks from the date the graded areas are seeded, a satisfactory stand of grass has not been produced, the graded area or unsatisfactory portions thereof shall immediately be renovated and reseeded. A satisfactory stand of grass is defined as a graded area or section of graded area that has:

5. No bare spots larger than three square feet;

6. Not more than ten percent of total area with bare spots larger than one square foot; and

7. Not more than 15 percent of total area with bare spots larger than six inches square.

8. The coverage guarantee shall apply to both temporary and permanent seeding. All seeding shall be guaranteed, and grass coverage shall be guaranteed for a period of two years from the date the graded area has been covered with topsoil and seeded (the "Completion Date") or from the date of the Notice of Termination (NOT) filed with TCEQ whichever is later.

9. Fertilizer. Fertilizer shall be spread on all seeded areas according to item 166 of the TxDOT specifications.

10. Soil retention blankets and liners.

11. Soil retention blankets and liners shall be installed according to item 169 of the TxDOT specifications. Class 1—Slope Protection is required on all slopes that are steeper than 6:1. Class 2—Flexible Channel Liners are required on all ditches or swales where the calculated velocity for a 100-year storm event exceeds six feet per second and where there is evidence of erosion within two years from the completion date. Slope protection and flexible channel liners shall be installed as recommended by the manufacturer. Flexible channel liners shall be selected as recommended by the manufacturer according to the calculated maximum stormwater velocity.

12. Restoration of eroded areas. Within the two-year warranty period, all eroded areas shall be repaired. Eroded areas and ruts shall be filled with top soil, the appropriate soil retention blanket and liner installed or reinstalled and the area reseeded.

K. Two printed copies of the stormwater pollution prevention plan and one Adobe portable documents format (pdf) copy of the plan shall be submitted to the designated official with the grading permit application. Five printed copies and one pdf copy of the approved grading plan shall be submitted before the grading permit is issued.

### 3.8.2 Review and approval

---

A. The designated official will review each application for a grading permit to determine its conformance with the provisions of this regulation. Within 30 days after receiving an application, the designated official shall, make reasonable effort to:

1. Approve the permit application;

2. Approve the permit application subject to such reasonable conditions as may be necessary to secure substantially the objectives of this regulation, and issue the permit subject to these conditions; or

3. Disapprove the permit application, indicating the reasons and procedure for submitting a revised application and/or submission.

B. Review and permit fees. Fees for review of grading plans and issuing grading permits shall be as set from time to time by the City Council.

### 3.8.3 Inspection

---

A. The designated official shall make inspections as hereinafter required and either shall approve that portion of the work completed or shall notify the permittee wherein the work fails to

---

comply with the erosion and sediment control plan and/or SWPPP as approved. Plans for grading, stripping, excavating, and filling work bearing the stamp of approval of the designated official shall be maintained at the site during the progress of the work. To obtain inspections, the permittee shall notify the designated official at least two working days before the following:

1. Start of construction.
2. Installation of sediment and erosion measures.
3. Completion of site clearing.
4. Completion of rough grading.
5. Completion of final grading.
6. Close of the construction season.
7. Completion of final landscaping.

B. The permittee or his agent shall make regular inspections of all control measures in accordance with the inspection schedule outlined on the approved erosion and sediment control plan and/or SWPPP. The purpose of such inspections will be to determine the overall effectiveness of the control plan and the need for additional control measures. All inspections shall be documented in written form and submitted to the designated official at the time interval specified in the approved permit.

C. The designated official shall enter the property of the owner as deemed necessary to make regular inspections to ensure the validity of the reports filed under the SWPPP if applicable.

## PART 4: WATER SYSTEM

### 4.1 Water System Improvements

#### 4.1.1 General requirements

- A. Water systems serving the subdivision or development shall connect with the city's designated and approved water supply and distribution system. Water facilities shall be installed to serve adequately each lot and shall be sized to conform to the city's water distribution master plan and other requirements of the city. The city may require owners to provide a water study, including adequate engineering data to support water demand projections, before final plans will be approved.
- B. All subdivisions shall be provided with a water system that meets the TCEQ requirements.
- C. In the corporate limits, all subdivisions shall be connected to the city's water distribution system or other approved alternate.
- D. The design shall conform to the latest criteria set forth in the AWWA Standards, as published by the American Water Works Association and the Texas Commission on Environmental Quality (TCEQ) requirements.

### 4.2 Water Lines and Services

- A. Water lines shall be in a public or private easement as determined by the city. Public easements shall encompass all public water lines and appurtenances, fire hydrants, fire department connections, fire lines, reduced pressure zone assemblies, and water meters. Private easements may be used for all facilities that are not maintained by the city to include but not limited to service lines, irrigation systems, commercial developments, fire protection systems on the owner's side of a meter or reduced pressure zone assembly, and fire tanks.
- B. Water mains shall be a minimum of eight-inch nominal internal diameter.
- C. Water mains of 8-inch diameter and larger shall be installed with casing beneath the roadway.
- D. Water lines shall not be located under paved surfaces where possible. Water lines shall be located between the right-of-way boundary line and the back of curb. If a sidewalk is located within the right-of-way boundary line, the water line shall not be located beneath the sidewalk pavement and shall be located between the right-of-way line and the back edge of sidewalk pavement.
- E. Dead end lines shall not exceed 150 feet in length unless approved by the City Engineer due to special and extraordinary circumstances. Dead end lines shall terminate at a fire hydrant/valve that shall be installed for maintenance purposes and may not necessarily be considered for fire hydrant density as required. Flush hydrants may be installed in lieu of hydrants for maintenance purposes if approved by the City Engineer at terminating points of dead-end lines for maintenance purposes only.
- F. A mega-lug plug shall be placed at the end of the dead-end line. No push on gaskets shall be allowed.
- G. Water services for each lot shall be in accordance with the City's standard details. All water services shall be marked on the curb.
- H. Markers shall be provided to mark all off-site water lines (min. 300' spacing).
- I. Water lines shall be constructed using the following materials or approved equal:

1. Solid wall polyvinyl chloride (PVC) pipe with integral bell; or
  2. Solid wall high density polyethylene (HDPE) pipe (for new systems only).
- J. When PVC pipe is used, 12-gauge single strand wire or metallic tracer tape, blue in color, shall be installed in the backfill material 24 inches above the top of the pipe in accordance with the manufacturer's recommendations. Each end of the wire or tape shall be connected to copper terminals embedded in concrete adjacent to the nearest water valve box.
- K. When HDPE pipe is used, the minimum wall thickness of the polyethylene pipe shall meet the following pressure applications: AWWA C906, DIPS SDR11 or SDR17 Pressure Class 200 psi, PE4710.
- L. Water lines shall be installed with a minimum cover over the top of the pipe of 48 inches.
- M. Water lines shall be pressure tested and disinfected in accordance with AWWA C601.
- N. All buried bolting shall be stainless steel.
- O. Stainless steel valve operator extensions are required where the depth to the operating nut is more than four feet.
- P. Water lines shall be extended to serve adjacent property or future developments. A valve shall be installed 20 feet from the end of lines that are to be extended.
- Q. The specification for materials and workmanship shall conform to the standard specifications.
- R. Large diameter water mains, 24-inch diameter and larger, will require specific design parameters coordinated with the City Engineer.

#### **4.3 Water Meter Boxes**

---

- A. Water meter box tops shall be set one-half inch to one and one-half above the curb, and an angle meter stop shall be set six inches (6") below the meter box top. Meter boxes shall have a one-inch wide slot from five inches (5") below the top of the box to the bottom of the box on the side facing the lot for service connection. Meter boxes shall not have locking lids. All meter boxes shall be located just outside of the right of way (1' off of the right of way inside private property).

#### 4.4 Water Tap and Meter Fees

1. Potable water tap, meter, and additional fees will follow the schedule below:

<b>Water Tap and Meter Fees</b>		
¾" Meter Tap	With Meter and Box Short Side	\$1,250.00
	With Meter and Box Long Side	\$2,400.00
	Meter and Radio Only	\$375.00
1" Meter Tap	With Meter and Box Short Side	\$1,350.00
	With Meter and Box Long Side	\$2,500.00
	Meter and Radio Only	\$450.00
2" Meter Tap	With Meter and Box Short Side	\$2,500.00
	With Meter and Box Long Side	\$4,050.00
	Meter and Radio Only	\$1,400.00
3" Meter Tap	Without Meter and Box Short Side	\$3,700.00
	Without Meter and Box Long Side	\$4,600.00
	Meter Vault Package	\$11,500.00
4" Meter Tap	Without Meter and Box Short Side	\$3,800.00
	Without Meter and Box Long Side	\$4,700.00
	Meter Vault Package	\$13,500.00
6" Meter Tap	Without Meter and Box Short Side	\$5,250.00
	Without Meter and Box Long Side	\$5,500.00
	Meter Vault Package	\$19,500.00
8" Meter Tap	Without Meter and Box Short Side	\$6,000.00
	Without Meter and Box Long Side	\$6,500.00
	Meter Vault Package	\$25,000.00
<b>Additional Fees</b>		
Boring for Road Crossing	Minor Highway Crossing (maximum 3 lanes)	\$625.00
	Line Crossing (more than 8 ft. of cover)	\$450.00
Raising or Adjusting Existing Meters	¾" - 2" Meter (up to 15 feet)	\$200.00
	4" - 8" Meter	Priced by Public Works Director
Relocation of Meter	¾" - 2" Meter (up to 15 feet)	\$500.00
	Meter Greater Than 2" or Relocation Longer than 15 feet	Priced by Public Works Director
Meter Boxes	Double Meter Box	\$250.00
	Single Meter Box	\$125.00
Locate an existing tap (non-refundable)		\$200.00
Short Tap with Removal of Asphalt and/or Concrete		\$750.00
Long Tap with No Asphalt Patch		\$575.00

2. Taps for water meter sizes larger than 1 ½ inch will be priced at the actual cost of labor, materials and equipment-same to be determined by the Public Works Director.

#### 4.5 Water Valves

- A. Valves shall be located such that the distance between valves is a maximum of 600 feet on

12-inch and smaller lines, or larger lines. Valves shall be furnished with stainless steel extensions, such that the working nut is a maximum of 48 inches below grade. Valve locations must be marked and etched in curb or in the surface of the street.

- B. Water valves shall be placed such that when a water line is taken out of service, only one fire hydrant is out of service.
- C. Gate valves will be designed to open to the left (counter-clockwise).
- D. Water valves shall be installed to allow a single section of water line to be isolated by closing only three valves.
- E. Flushing valves shall be installed on all dead-end lines having water services connected thereto. Flushing valves shall be constructed according to the installation details for a two-inch water service.
- F. All water valves shall be of the resilient seat type.
- G. Bonnet bolts and all other exposed bolts on buried valves shall be stainless steel.
- H. Stainless steel valve operator extensions are required where the depth to the operating nut is more than four feet.
- I. Off-site markers shall be provided at all off-site valve locations.

#### **4.6 Fire Protection**

---

- A. The Building Official or their designee will review all plans and specifications of all proposed commercial and residential development in the city and will determine whether or not adequate fire protection may be afforded the building or buildings situated or proposed to be situated on such property with existing or proposed fire hydrants and water lines.
- B. If, in the opinion of the Building Official, adequate fire protection requires additional fire hydrants and water lines to serve proposed developments, the Building Official will direct the owner of the property, in writing, to locate at predesignated positions on the property a fire hydrant or hydrants and adequate water lines to provide adequate fire protection at the owner's expense. The location and number of fire hydrants and water lines shall be situated as to afford adequate fire protection to all buildings located or proposed to be located on the property. Such installation to be completed in such reasonable time as the Building Official may direct.
- C. Water service must be sufficient to meet fire flow requirements of the proposed development for domestic and industrial purposes, as set forth in the fire code and all appendices thereto, except where a suitable alternative means of fire protection is approved by the city's Building Official.
- D. All underground lines shall begin at the point of connection to the underground circulating public/private water main. A valve shall be provided at the point of connection such that the fire sprinkler underground service line can be isolated from the public/private water distribution system.
- E. Underground piping shall have a 10-foot minimum separation from all other utilities and placed in a separate trench. Underground piping within 5-feet of the building may be combined with other utilities for entrance into the building.
- F. All underground lines shall terminate at the top of the spigot no more than 5-feet inside the building and 1-foot above finished floor.
- G. All ductile iron, retaining rods, and other non-corrosive resistant components shall be externally coated for corrosion or poly wrapped.



- H. All underground piping shall be a minimum of Class 200 DR14 or greater.
- I. Water supply shall be provided in conformance with the requirements of the respective standard; however, every fire protection system shall be designed with a minimum 5 psi safety factor at 20 psi residual on City mains.
- J. The water supply test for the hydraulic design of fire protection system shall be witnessed by the City. The results of the flow test shall be within one year of the sprinkler plan submittal. The exact location of the static/residual hydrant and the flow hydrant shall be indicated on the design drawings. All fire protection plan submittals shall be accompanied by a water flow test report.

#### **4.7 Fire Hydrants**

---

- A. All fire hydrants must meet required city standard fire hydrant specifications.
- B. All fire hydrants must conform to requirements and test of AWWA Standard for Dry Barrel Fire Hydrant – C502-94 or latest revision thereof, as they pertain to the design, component materials, construction and manufacture, except as modified or supplemented hereinafter.
- C. Operating nut must be one bronze piece; must be non-rising, pentagonal in shape, measuring 1-1/2" from point to flat; must open counterclockwise.
- D. Hold-down nut must incorporate an integral resilient weather seal and be e-coated epoxy.
- E. Lubrication chamber must be provided; must be sealed top and bottom with "O" rings; must be filled with lubricant which shall be food grade grease. The design shall be such that the thrust collar and the threaded operating parts are automatically lubricated each time the hydrant is cycled. There must not be less than two (2) "O" rings separating the lubrications reservoir from the waterway and that portion of the stem contracting these "O" rings shall be sleeved with bronze. An anti-friction device must be in place above the trust collar to further minimize operating torque.
- F. Hydrants bonnet must be attached to the upper barrel by not less than four (4) bolts and nuts, with an inserted flat rubber gasket as a pressure seal.
- G. Hydrants must be "three-way", having two (2) 2-1/2" hose nozzles and one (1) 5" Integral Storz Nozzle factory installed. Nozzles must attach clockwise into hydrant barrel utilizing "O" ring pressure seals and be held in place by a ductile iron retaining ring. "Traffic-model" having upper and lower barrels joined approximately 2" above the ground line by a separated and breakable "swivel" flange providing 360-degree rotation of upper barrel for proper nozzle facing. This flange must employ not less than eight (8) bolts. Stem must be two-piece, 1" x 1" square (excluding threaded or machined areas) and must be connected by a breakable stem coupling that is e-coated epoxy near the ground line flange. Pins used in conjunction with the stem coupling must be stainless steel with stainless retaining pin.
- H. The inside diameter of the hydrant barrel shall not be less than six and one-eighth inches (6-1/8). Hydrant to be e-coated primer and Dayton purple polyurethane top coat.
- I. Main valves must be compression type closing with the pressure and must be not less than 5-1/4 diameter. The composition of the main valve must be molded rubber or neoprene, having a durometer hardness of 95 (+) (-) 5 and must be not less than 1: thick.
- J. Hydrants must be equipped with 4 drain valves, which drain the barrel when the hydrant is closed, and seal shut when the hydrant is opened. Hydrant drain assembly shall utilize a spring to give positive shut off with a maximum of three complete turns of the operating nut. This will allow the hydrant to be throttled without damage to the drain mechanism.

K. Seat ring and drain ring must be bronze (ASTM B-62) and work in conjunction to form an all bronze drain way. Four (4) drain openings are required in bronze drain ring. Seat ring seals must be “O” rings. The 6” shoe connection must be specified (flanged, A/C, M.J., etc.).

L. Hydrant must have a working pressure rating of 250 PSIG and be tested at 500 PSIG; must have a manufacture’s published warranty against defects in material or workmanship for a period of (10) years from date of manufacture; must be American Flow Control, 5 ¼” B-84-B, Mueller A423 or Engineer pre-approved equal.

M. Upon request, supplier must furnish flow data, indicating friction loss in PSI at the flow of 1,000 GPM from the pumper nozzle, such friction loss must not exceed 3 PSI. Hydrants shall be warranted by the manufacturer against defects in material or workmanship for a period of ten (10) years from date of manufacture. The manufacturing facility for the hydrant must have current ISO 9001 certification.

#### 4.7.2 Fire department connections

---

A. The city requires a fire department connection for all fire suppression sprinkler systems.

B. For automatic wet, automatic dry or semi-automatic, or one five-inch inlet or two 2½-inch inlets are required.

C. For manual dry and manual wet systems, one five-inch inlet or two 2½-inch inlets are required for the first 1,000 gallons per minute of sprinkler system demand. An additional two 2½-inch inlets are required for each additional 250 gallons per minute of sprinkler system demand.

D. The fire marshal may waive the requirement for a fire department connection for residential fire suppression sprinkler systems.

E. Location of fire department connection shall be approved by the City Engineer.

F. All FDC’s shall be equipped with locking Knox FDC Caps. Knox products may be ordered online at [www.knoxbox.com](http://www.knoxbox.com).

G. Check valves shall be accessible for 5-year inspection. If located underground, the valve shall be installed within a meter can/valve box.

H. Valves and vaults shall be constructed as directed by the City Engineer and City Engineer according to the city standard details.

#### 4.7.3 Fire hydrant location and spacing

---

A. Fire hydrants shall be located per Section 14.302.10 Public Water System, City of Dayton Unified Development Code.

B. The number and spacing of fire hydrants shall not be less than that required by the fire code and all appendices thereto.

C. Fire hydrants shall be installed along all fire lane areas for nonresidential property as follows:

1. Within 150 feet of the main entrance.
2. Within 50 feet of any fire department connection.

D. Generally, no fire hydrant or fire department connection shall be located closer than 50 feet to a building or structure unless approved by the fire marshal.

E. In instances where access between the fire hydrant and the building that it is intended to serve may be blocked, extra fire hydrants shall be provided to improve the fire protection.

Railroads, expressways, major thoroughfares and other man-made or natural obstacles are considered as barriers.

F. All portions of all buildings shall be located within a 300-foot hose lay from fire lane or public roadway having a fire hydrant spacing meeting the requirements of these regulations.

G. The hose lay shall be measured as a fire hose would be laid from the fire lane or roadway along aisles that are at least 22-feet wide and that are not obstructed by fences, buildings, stored materials, railroads or other obstructions.

H. Fire hydrants located on the opposite side of a street, designated as four lanes or larger on the current city thoroughfare plan, shall not be considered acceptable for meeting hydrant coverage requirements.

I. Fire hydrants shall be located in accordance with the City's standard details.

J. Fire hydrants shall be protected from traffic damage. Fire hydrants shall either be placed behind a six-inch high curb or protected by six-inch concrete filled bollards approved by the city.

#### 4.7.4 Inspection Requirements

---

A. Visual: All underground piping, joints, and thrust blocks must be uncovered and exposed, with labeling of the pipe legible from grade. All ductile iron, retaining rods, and other non-plastic components shall be externally coated for corrosion and poly wrapped.

B. Hydrostatic Test: visual inspection must be approved prior to hydrostatic test. The test will be at 200 psi or at 50 psi pressure in excess of the maximum static pressure when the maximum static pressure exceeds 150 psi, for a minimum of two hours. Testing to be from the gate valve to the top of the spigot, no pressure drop or gain allowed.

C. Flush: Upon completion of the underground hydrostatic test, the underground piping will be flushed, witnessed by the City. All piping used to flush must be properly secured or restrained. The flushing must be completed prior to stacking the riser to the overhead piping.

D. Fire Sprinkler Underground Final: Final sign-off of completion of all inspection and the receipt of all State required paperwork.

#### 4.7.5 Water well provisions

---

A. All water wells shall be considered private and shall be owned and maintained by the owner. All water wells shall meet all regulations and requirements of the city, the county health department, and the state.

B. Permits for new or replacement water well system shall be obtained from the city and the county health department. The director of public works shall review and approve water well systems on behalf of the city provided all city standards have been met.

C. Private water wells may not be constructed for domestic service other than for irrigation, agricultural use, or livestock watering.

#### 4.8 Backflow Prevention Program

---

A. The installation location of all backflow prevention assemblies shall be in an area that provides a safe working environment for testing and maintenance. This area shall be readily accessible, away from electrical hazards and free from dirt. The location must meet requirements of all other local authorities i.e. Fire, Planning, Zoning, or Texas Department of Transportation (TxDOT).

B. The installation shall be in accordance with the manufacturer's information, Texas

---

Commission on Environmental Quality (GI-411) and the City of Dayton. Installation of backflow prevention assemblies shall be upstream of the first branch line leading off the service line. If the City determines that it is impossible or impractical for the backflow prevention assembly to be installed outside, it may be installed just inside the building. All backflow assemblies shall be installed in a horizontal direction. The backflow prevention assembly must be installed by a licensed plumbing, or utility contractor. Fire line services require a licensed fire sprinkler contractor.

C. The type of backflow prevention assembly installed will be determined by the City and shall depend upon the degree of hazard as stated in the ordinance. If the hazard cannot be determined, then a reduced pressure principle assembly shall be installed. The backflow prevention assemblies installed shall be City of Dayton approved backflow prevention assemblies which include the shut-off valves on each end of the unit and are considered part of the unit. These shut-off valves shall be those approved with each specific unit and there shall not be any substitutions. There shall be four test cocks provided as specified in the section titled "Approved Assemblies and Materials."

1. On the upstream side of the first shut off valve (upstream being the side closest to the property line)
2. Between the first shut off valve and the first check valve.
3. Between the first and second check valve.
4. Between the second check valve and the second shut off valve.

D. All installations should be installed where easily accessible for testing and maintenance.

E. Reduced pressure zone backflow prevention assemblies (RPZ) shall be installed above ground outside zoning setback areas and according to City of Dayton's standard details.

F. The minimum height from the relief port to the ground shall be 12" and the maximum height shall be 30". A floor drain or an air-gap drain shall be provided for RPZ's installed inside of buildings (minimum drain sizes are listed in these specifications). For 3/4" - 2", the clearance for an RPZ installed inside a building shall be 4" minimum from the wall to shut off valve, 30" minimum from the wall or any obstruction on the side utilized for testing and 6" minimum on the other to the assembly. For 3" - 10" RPZ, the clearance shall be 30" minimum from the wall or any obstruction on the side utilized for testing and 12" minimum on the other. RPZ's must be installed in an upright horizontal direction.

G. The backflow prevention assembly is the responsibility of the customer to install and maintain. If damage occurs to the assembly for any reason it is the customers responsibility to repair or replace it.

H. It is recommended that protective structures be used to prevent freezing or vandalism for backflow prevention assemblies installed outside above ground. The backflow prevention assembly shall be protected from freezing in accordance with current State Plumbing Code. The backflow prevention assembly must be readily accessible for maintenance and testing including removing the entire assembly. Adequate drainage shall be provided by hinged door or drain ports along the bottom of the walls of the protective structure. The minimum drain size shall be provided according to current state plumbing code. Insulation shall not be wrapped around the assembly.

I. If the structure is non-removable and must be entered in order to test or repair the assembly, the same minimum and maximum clearance that is specified for vault installations shall apply.

J. Covers or doors placed above a protective structure or vault shall be lightweight and shall

have adequate width and length to remove the entire assembly. Doors or covers for 3" - 10" vault installations shall be double hinged.

K. Fire line installations shall be as follows: High hazard fire line installations require a reduced pressure zone assembly (RPZ) as stated in the ordinance. Moderate hazard fire line installations require a double check valve assembly. It is recommended, if possible, if a booster pump exists, that it be approximately 100-feet downstream of the backflow prevention assembly. **Strainers shall not be installed on fire lines. All fire line installations shall be protected to a min. of 40 degrees or as required by current building code.**

L. Fire line services with only one fire hydrant with a maximum of distance of 100- feet from the property line shall not require backflow prevention. All assemblies on a fire line, or combination domestic and fire, shall be fire line approved installations with OS & Y type shut-off valves. These valves shall be provided with supervisory tamper switches as required by current Building Code enforced by the Fire Marshal.

M. Residential lawn irrigation service installations shall be as follows:

1. The backflow prevention assembly must be installed on the irrigation service line before any branching of the private system and in accordance with all other City of Dayton Installation Guidelines and Standard Details for Backflow Prevention Assemblies. The assembly may be installed adjacent to the house and shall be outside the footprint of the house.

2. All residential lawn irrigation system services tapped from the residential domestic service shall require a backflow prevention assembly on the irrigation service line before any branching of the irrigation system and in accordance with City of Dayton Installation Guidelines and Standard Details for Backflow Assemblies.

N. All backflow testers and contractors that perform mandated backflow assembly tests within the City of Dayton jurisdiction will be required to submit the result of each backflow test and maintenance report to the designated agent.

## PART 5: WASTEWATER SYSTEM

### 5.1 Wastewater System Improvements

#### 5.1.1 General requirements

- A. All subdivisions shall be provided with sewage disposal system that meets the TCEQ requirements. Subdivisions inside the city limits and within the extraterritorial jurisdiction shall be connected to the city's sanitary sewer system or other approved alternative.
- B. The owner shall furnish and install the complete sewage system, including the mains, manholes, cleanouts, Y-branches, service laterals for all lots, lift stations, and appurtenances.
- C. Should the subdivision or development abut and use a sewer main of the city, the owner shall pay the city a rough proportionate share as determined by the City Engineer.
- D. All additions to the sanitary sewage system shall conform to the city's master sewer plan and other requirements of the city. The city may require a sanitary sewer study, including adequate engineering data, to support projected sewer flows before final plan approval. The proposed wastewater discharge of a proposed development shall not exceed the capacity of the wastewater system based upon required studies.
- E. Off-site sewer utilities shall be constructed by the owner in accordance with rough proportionate share as determined by the City Engineer.
- F. Developer shall provide a design report for all proposed facilities compliant with 30 TAC §217; the recommendations of NFPA 820; the Hydraulic Institute Pump Intake Design Standards (ANSI/HI 9.8-2012) generally and Section 9.8.3.3 specifically. The design report shall include a lift station start-up and commissioning plan outline. The final commissioning plan shall be included in the final construction documents.

#### 5.1.2 Sewer lines and services

- A. Sewer lines shall be in a public or private easement as determined by the city. Public easements shall encompass all public sewer lines, manholes, cleanouts and appurtenances. Private easements may be used for all facilities that are not maintained by the city to include but not limited to service lines not within a street right-of-way, lift stations serving only one lot, commercial developments, and grease and sand traps.
- B. Sewer lines, including service laterals, shall be televised prior to paving construction and acceptance.
- C. Sewer pipe shall have a minimum internal diameter of eight inches.
- D. Sewer service for each lot shall have a minimum, internal diameter of four inches. Minimum cover at the property line shall be four feet. Green tracer tape or an alternate color approved by the City Engineer shall be installed to indicate the location of the sewer stub out.
- E. Dead-end lines shall end with a sanitary sewer manhole.
- F. Off-site markers shall be provided for all off-site sewer lines (18" min. above grade).
- G. Sewer lines shall be constructed using the following materials or approved equal:
1. Solid wall polyvinyl chloride (PVC) pipe with integral bell;
  2. Ribbed profile PVC pipe for sizes 24 inches in diameter and larger; or
  3. Closed cell profile PVC pipe for sizes 18 inches in diameter and larger, or
  4. Solid wall high density polyethylene (HDPE) pipe (for new systems only).



H. All stream crossings, railroad, and state highway bores shall be encased in a steel encasement pipe.

I. Manhole spacing shall be in accordance with the Unified Development Code and TCEQ requirements.

J. When HDPE pipe is used, the minimum wall thickness of the polyethylene pipe shall meet the following pressure applications: AWWA C906, SDR17 or SDR19, PE4710

K. Sewer lines shall be marked with APWA compliant detectable tape.

## 5.2 Manholes and cleanouts

---

### 5.2.1 General requirements

---

A. Manholes shall be lined cementitious concrete or polymer concrete construction. Cementitious manholes may be cast-in-place or precast.

B. Manhole covers shall be not less than 30 inches in diameter.

C. Fiberglass rain guards and rubber chimney seals are required for manholes.

D. Cleanouts shall be installed with removable plugs.

E. Cementitious manholes shall be designed and manufactured per ASTM-478 and lined with corrosion resistant materials acceptable to the City Engineer, installed only by manufacturer-certified installers and tested by manufacturer-certified third-party inspectors acceptable to the City Engineer.

F. Fiberglass manholes shall be designed and manufactured in accordance with ASTM D-3753-14.

G. Manhole penetrations shall comply with ASTM C-923.

H. Where the flow line of the sewer is 24-inches or greater above the flow line of the manhole, provide a manhole drop connection per the standard construction detail.

### 5.2.2 Inflow preventer and sewer gas ventilation device

---

A. Materials: Manhole inserts shall be manufactured of high quality DuPont Zytel ST801-NC010A nylon 66 resin or stainless steel, corrosion proof materials suitable for exposure to road salts, oils, fuel, hydrogen sulfide, dilute sulfuric acid and other gases common to sewerage systems. The material shall be freeze-thaw resistant and withstand extensive temperature range variations. The inserts shall be properly sized for the specific manhole frame and cover in which they will be fitted and shall be installed in a 1-3/8 inch diameter hole and be capable of withstanding 6,000 pounds of compressive force. The insert shall be capable of relieving gas and vacuum pressure from the sewerage system and shall be complete with a manhole lid gasket between the manhole lid and the manhole frame. The gasket shall be 1/8 inch thick and made of commercial grade EPDM (ethylene propylene diene monomer) blended rubber in 60 durometer hardness. The gasket shall be envelope ribbed on one side to provide a positive seal. The manhole frame shall be cleaned using a disc sander and then applying acetone. The cleaned area shall then be treated with OPSHO rust treatment in accordance with the manufacturer's instructions. The gasket shall then be "roughed" on one side with a belt sander and the "roughed" side then glued to the manhole frame with Chemrex CX-948 glue to form a long-lasting bond in wet or dry conditions.

B. Extension Pipe: If the existing manhole is susceptible to going under water, an extension pipe can be provided and installed to extend above the high water level which will still allow the



manhole to vent dangerous sewer gases during periods of high water. This pipe shall be Max-Gain pultruded fiberglass tube made of isophthalic polyester resin and e-glass to be UV and corrosion resistant, flexible and strong.

C. Check Valve: If the existing manhole is susceptible to going under water and the extension pipe will not work or the manhole is in the roadway, or the manhole is located in a highly visible area, a Sewer Sentry check valve made of the same type high quality materials can then be provided and installed to prevent storm water from entering the manhole through the one inch vent hole of the Sewer Sentry. Once the storm water has subsided, the weep hole in the check valve will allow it to drain and continue to enable the sewer gases to escape the manhole. This check valve would be installed on the threaded bottom of the Sewer Sentry device in place of the threaded securing nut.

### 5.3 Lift Stations

---

A. Lift stations shall be installed only if approved by the City Engineer or shown on the master wastewater plan for the city.

B. All lift stations shall be designed using wet pit submersible pumps, reinforced concrete or fiberglass wet wells with separate check valve vault and flow meter vaults.

C. Permanent lift stations and all appurtenances shall be constructed on property dedicated to the city in fee simple. Temporary lift stations and appurtenances may be placed in a public easement. Whether a lift station is temporary or permanent shall be determined by the city.

#### 5.3.2 Lift station design.

---

A. Lift stations shall be designed by a professional engineer licensed in the state. Construction plans submitted for the lift station shall include wet well hydraulic and structural design, vault designs, pump specifications, pipe design, and applicable instrumentation including approved telemetry equipment.

B. Lift stations must be designed in accordance with 30 TAC 217, NFPA 820, Hydraulic Institute Pump Intake Design Standards (ANSI/HI 9.8-2012 generally and Section 9.8.3.3 specifically).

C. Provide calculations for the average design flow and flow peaking factor.

D. Submit system curve calculations and a plot of System Flow versus System Head to the City of Dayton for review and comment. Include appropriate system information; static head, force main length and size and roughness coefficient assumptions, meters, valves and fittings, used in the system curve calculations.

E. Proceed with pump selection when the city has accepted the calculated system curve.

F. Select pumps to:

1. Provide a firm lift station capacity equal to peak flow conditions.
2. Operate in the pump's Preferred Operating Region (POR).

G. The firm lift station capacity is the capacity with the largest pumping unit out of service. For duplex lift stations each pump capacity is equal to peak flow.

H. The pump's POR is defined in ANSI/HI 9.6.3 as a range of flow to either side of the Best Efficiency Flow (BEP) within which the pump's hydraulic efficiency is not substantially degraded. Generally, the POR is between 70% to 120% of BEP. Provide confirmation from the pump manufacturer of the actual POR.

- I. Select pumps to operate inside of POR to maximize pump life and reliability and minimize energy consumption. City Engineer may allow pump selection outside POR upon specific review.
- J. Submit required Net Positive Suction Head (NPSH) calculations to the city for review and comment.
- K. Submit a plot of Pump Flow versus Pump Head combined with the plot of System Flow versus System Head to the city for review and comment. Include appropriate pump data; shutoff head, pump efficiency and BEP, pump POR limits, NPSH required and NPSH available.
- L. Pump selection shall be subject to approval by the city.
- M. An additional (spare) pump shall be provided. In cases where the identical pump and impeller is already available to be used as a spare, a variance for providing a spare pump shall be requested. Written authorization from city of Dayton staff must be provided at the time of inspection if a spare pump will not be provided.
- N. Velocity in all piping in a lift station and all force mains shall be under 8 fps. In a force main manifolded with other lift stations, the minimum velocity the proposed lift station shall maintain while all other lift stations are operating shall be 2 fps.
- O. For large pumps provide permanently installed lifting crane.

#### 5.3.3 Wet Well

---

- A. Design the wet well to provide uniform, steady flow free of swirl and entrained air into the pump. Follow the recommendations and requirements published in ANSI/HI 9.8 Rotodynamic Pumps for Pump Intake Design and the pump manufacturer's requirements.
- B. Submit information from the proposed pump manufacturer that the pump design has adequate submergence for operation.
- C. Submit wet well flotation calculations, based on an empty wet well and the ground water table at proposed finished grade, to city for review and approval.
- D. Vent the wet well with a minimum four (4) inch diameter pipe as indicated on the City of Dayton Standard Construction Details.
- E. Set wet well top elevation a minimum of two (2) feet above the FEMA 100-year flood elevation for the site. Provide flood proof hatches in situations where the wet well top slabs elevation cannot be set a minimum of two (2) feet above the FEMA 100-year flood elevation. In all cases, set the wet well vent a minimum of two (2) feet above the FEMA 100-year flood elevation.
- F. Design a single pipe inlet into the wet well. Collect multiple pipes entering the site into a manhole upstream of the wet well. Design pipe inlet into wet well to minimize aeration and turbulence.
- G. Protect all exposed surfaces and structures, including walls and underside of top slab, riser piping, and metallic influent piping inside wet well, from corrosion.
- H. Submit geotechnical report with soil boring(s) for proposed wet well location.

#### 5.3.4 Minimum Wet Well Volume

---

- A. The minimum required wet well volume is determined by satisfying the following under Average Design Flow (ADF) conditions:

1. Provide the greater of; adequate pump submergence or the required NPSH.
  2. Provide working volume (the volume between pump on/off elevations) sufficient to limit the number of pump on/off cycles to between two (2) and eight (8) per hour, or fewer as required by the pump manufacturer.
  3. Provide for alarm level settings.
- B. Depth Based on Control Elevations
- C. The depth of the wet well shall be set to accommodate the following level control system parameters:
1. "Lead Pump Off"
  2. "Lead Pump On"
  3. "Lag Pump On"
  4. "High Water Telemetry"
  5. "High Water Alarm"
- D. No components requiring service may be placed in the wet well unless they can easily be removed without entering the wet well.
- E. No carbon steel parts may be used within the wet well of the lift station. Stainless steel, aluminum, bronze, PVC, ductile iron may be used. Plated steel parts may not be used.
- F. The interior of the wet well shall be lined with corrosion resistant materials acceptable to the City Engineer, installed only by manufacturer-certified installers and tested by manufacturer-certified third-party inspectors acceptable to the City Engineer.
- G. Fixed standby generators may be required at lift stations as determined by the City Engineer. Lift stations so equipped will include an automatic transfer switch with programmable exercise cycle. All lift stations shall include a generator connection device compatible with the City's mobile generator.
- H. No bare steel or painted steel materials shall be used in the construction of the lift station or its components. All steel parts shall be stainless steel or hot dipped galvanized and electro-galvanized steel may not be used. The generator enclosure may be factory painted steel.
- I. Access hatches to the wet well and vaults shall be ASSHTO H-20 rated, internally-drained, channel frame-style, air-tight sealing gasketed, spring-assisted, lockable, aluminum or stainless steel. The hatch to the wet well shall be fitted with integral secondary fall protection grating.
- J. Odor control devices shall be installed for the lift station and at the termination of the force main as approved by the City Engineer. Odor control shall be provided at the lift station.

#### 5.3.5 Electrical, instrumentation, and controls

---

- A. The voltage supplied for the pump shall be three-phase, 480 volts. Converting single-phase power to three-phase power using additional mechanical equipment shall not be allowed.
- B. All electrical panels shall be NEMA 4X stainless steel construction. Protect enclosures from the wet well atmosphere by an air gap of 66" minimum. Exposed conduit shall be Sch. 40 aluminum with galvanized malleable iron fittings. Conduit clamps and attachment devices shall be aluminum or stainless steel.
- C. Design enclosures to facilitate lock-out/tag-out procedures.
- D. Unless otherwise regulated, provide only braided or stranded wire. Minimum conduit size allowed is one 1- inch in diameter.

- E. Provide aluminum conduits installed in exposed areas. Provide PVC conduits installed underground or encased in concrete. Transition from concrete encased PVC to aluminum inside the concrete encasement. Coat the portion of aluminum conduit inside the encasement with asphaltic urethane paint.
- F. For submersible stations, provide a separate 3-inch diameter conduit for each pump lead. Provide duct-seal to isolate sewer gases from the control panels.
- G. The control panel for the pumps shall be installed under a metal sunshade that will prevent the sunlight from directly striking the panel between 10:00 a.m. and 5:00 p.m. at any time during the year. The sunshade shall be designed to withstand all live and dead loads required by the building code.
- H. Wet-well level control shall be achieved using an ultrasonic level indicating transmitter or other device approved by the City Engineer.
- I. Submersible pumps shall be provided with moisture and motor over-temperature sensors.

#### 5.3.6 Site requirements

---

- A. The lift station, controls, valve vaults, generators, and ancillary equipment shall be enclosed by an 8-foot masonry or painted steel picket fence. In residential areas, the fence shall be a powder coated steel picket decorative fence. A double leaf gate at least 16 feet wide shall be provided with locking device and gate leaf holdbacks.
- B. Minimum site dimensions: fifty (50) feet square in size Larger sites may be required based on the lift station capacity, features, odor control systems, site orientation, etc.
- C. A reinforced concrete slab will be required from one foot outside the fence and cover the entire fenced in area. The reinforced concrete slab shall be a minimum of five inches thick.
- D. A one-inch minimum potable water service is required. The water service may be set in a standard 18-inch galvanized water meter box with a one-inch brass angle stop. A reduced pressure backflow preventer shall be installed in an electrically heated enclosure located above ground within the fenced area.
- E. The site shall be graded to drain away from the station to prevent stormwater inflow or infiltration into the wet-well. The site shall be covered by number 57 stone outside the limits of the concrete pad. The site shall also be Xeriscaped or landscaped in accordance with these standards.
- F. The site shall be located outside of the 100-year floodplain.
- G. The site shall not be located within 150 feet of an existing or proposed residence. In no instance shall an existing or proposed residence be located on more than one side. The distance is measured from nearest property line.
- H. A reinforced concrete driveway shall be constructed from a public street or concrete alley to the entrance to the lift station. The driveway shall be not less than 12 feet wide and five inches thick.
- I. The lift station site driveway shall include driveway area for maintenance vehicles to park off the public roadway while performing maintenance. The minimum driveway length shall be 15 feet off the back of curb line of the proposed street per the city's master thoroughfare plan.
- J. A concrete driveway turning area is required where access drives extend more than 50 feet from the main roads unless approved by the City Engineer. The driveway area shall have a "T" shaped with the applicable turning radius. The minimum driveway width shall be 12 feet.

- K. Front on an all-weather publicly maintained roadway or having approved alternate access.
- L. Signage: Weather-durable sign with name of lift station and a twenty-four (24) hour emergency telephone number. Mount at a conspicuous point on the fence.
- M. Set utility power pole outside the fenced area in a manner so the electric meter can be easily read from outside the fenced area. Run all on-site power lines underground.
- N. Provide adequate exterior area lighting for the interior of the fenced area. Provide adequate task lighting for safe and efficient night time maintenance/operational activities. Provide a switched separate circuit for exterior area lighting at the control panel. Provide switches for individual task lighting areas.
- O. Landscaping plans for the lift station site must be approved by the City.

#### 5.3.7 Protection of Electrical Panels and Controls

---

- A. The City has two basic scenarios for protecting electrical and control panels at its typical submersible lift station sites. For new or upgraded lift stations, the scenario will be determined by the City generally based on capacity and siting constraints. General guidelines are shown below.
- B. Enclosed structures (control building) are required and shall be one of the following types:
  - 1. Prefabricated FRP (fiberglass reinforced plastic) enclosed structures are available in standard sizes and useful for stations under 25 horsepower. An HVAC system is not provided. NEMA 4X, 316 stainless steel panels are required.
  - 2. Prefabricated, precast concrete enclosed structures are available in standard or custom sizes and useful for station sizes 25 horsepower and larger. An HVAC system is typically required for the enclosure.
  - 3. Custom built masonry and frame construction enclosed structures are custom sized and typically used at stations larger than 100 horsepower. An HVAC system is provided for the enclosure.
- C. Enclosed structure exception: This scenario becomes necessary for existing lift station upgrades with site constraints. The following situations can occur under the no enclosed structure scenario:
  - 1. A sun/rain hood constructed of 316 stainless steel is preferred to shield the required NEMA 4X, 316 stainless steel panels.
  - 2. When extreme site limitations exist only NEMA 4X, 316 stainless steel panels are required.

#### 5.3.8 Instrumentation and Controls

---

- A. General: All lift stations shall have SCADA telemetry equipment installed, at the expense of the owner that interfaces with the city's SCADA system and meets the city's protocol and specifications. The SCADA system shall be designed, furnished and installed by the city's designated SCADA system integrator.
- B. Instrumentation:
  - 1. Provide the following minimum instrumentation at each lift station:
  - 2. Wet well Level Measurement by Ultrasonic Level Technology.
  - 3. Pump Lead, Lag, Off control via float switches.
  - 4. Backup level control and monitoring via float switches (High and Low level, High Alarm)

5. Force Main Pressure Sensor and Gauge
  6. Intrusion Switches for equipment enclosure or building, and SCADA Panel
- C. Power Distribution:
1. Include a portable generator connection receptacle and associated breaker/disconnect to connect generator power and disconnect normal power in the Motor Starter. Provide a Phase/Voltage monitor and lightning arrestor on the main power distribution lines in the pump control panel.
  2. Provide a suitably sized control power transformer to supply 115 VAC control power to loads as indicated in the standard electrical details.
- D. Single Speed Pumps - Motor Starters:
1. Motor Starters: NEMA type starters, heavy duty industrial design with electronic overload protection.
- E. Single Speed Pumps - Soft Starts:
1. Motors rated at 20 HP or larger: Provide Soft Start Motor Controllers with automatic bypass contactor function.
- F. Variable Speed Pumps - Variable Frequency Drives (VFD):
1. Variable speed pumping will be evaluated for all major stations and for smaller stations that discharge to manifolded force mains or have direct influence on treatment plant operations. Evaluations will compare the additional capital and maintenance cost of VFD's energy saving benefits and operating control benefits. VFD's should include maintenance bypass contactors.,.
  2. Provide air-conditioned enclosures and maintenance bypass contactors for VFD applications.

#### 5.3.9 Control Overview

---

- A. Standard Duplex Pump Station (Fixed Speed Pumps):
1. Primary Control: Float based control with pump alternation to equalize run times.
  2. Backup Control: High and Low alarm floats. When the High-Water level alarm float is activated, both pumps are started. The pumps will continue to run until the Low- Level float is activated.
  3. When the High-Water Alarm float is activated, the local audible and visible alarm will be activated.
  4. Secondary level system can be requested to be incorporated into controls.
- B. Standard Triplex Pump Station (Variable Speed Pumps):
1. Primary Control: PLC based control, running a wet well level control algorithm with lead/lag capability. Incorporate runtime accumulation and pump alternation into the lead/lag algorithm to equalize run times of all three pumps.
  2. Start lead pump at minimum speed when the wet well level exceeds the wet well Operating Level setpoint and adjust the speed to control wet well level. Start the lag pump when the lead pump reaches 100% speed and the wet well level reaches the lag pump call setpoint and adjust the speed of both pumps to control wet well level.
  3. The lead and lag pumps will ramp to match speed output to control wet well level.



4. Provide operator adjustable setpoints for: Wet well Operating Level, Lead and Lag pump start and stop setpoints. Configure the operator adjustable setpoint to be adjusted from the Operator Interface Terminal or from the SCADA system.
5. Backup Control: High and Low alarm floats. Override PLC control and start two pumps at a preset speed when the High-Water Level alarm float is activated. Stop the pumps when the Low-Level float is activated.
6. Activate the local audible and visible alarm when the High-Water level alarm float is activated.
7. Incorporate an automatic lift station drawdown test program into the PLC programming.
8. Configure the PLC program to provide a periodic wet well cleaning cycle by running the pumps at full speed to preset low wet well setpoint. Configure the PLC program for the duration of and time interval between cleaning cycles to be operator adjustable.

#### 5.4 Force Mains

---

- A. Force mains shall be designed per 30 TAC §217.
- B. Within the lift station site, force mains shall be mechanically-restrained and blocked ductile iron, lined with minimum of 40-mil NDT ceramic epoxy lining (Protecto 401 by Induriron, no equal).
- C. Force mains shall include a by-pass assembly with full-sized quick-disconnect to allow the lift station pumps and valves to be completely bypassed for major maintenance or emergency operations events.
- D. Force main design shall incorporate provisions for hydraulic transient mitigation as need to assure long-term, reliable operations of the facility Air release valves and force main discharge points shall be provided with passive odor control devices designed for easy maintenance access including dedicated isolation valves.

#### 5.5 On-site treatment

---

- A. The owner of the subdivision or development shall construct the necessary water facilities to serve the subdivision. If it is practical to construct sanitary sewer facilities and connect to a sanitary sewer facility with approved treatment facilities, then the owner shall construct the necessary sanitary sewer facilities to serve the subdivision properly.
- B. The city has determined that it is practical to construct off-site sanitary sewer lines to connect existing sanitary sewer lines according to the following equation:
  1.  $L = 500 \times n^{0.6}$   
where:  
L = Length of off-site sanitary sewer line that must be constructed (feet).  
n = number of equivalent residential connections in the entire development. An equivalent residential connection generates 300 gallons per day of wastewater on an average day.
- C. All planned developments shall be connected to the city's sanitary sewer system regardless of the length of the off-site sanitary sewer lines required to make such connection.
- D. On-site wastewater treatment systems may not be used if the distance from the nearest corner of the development to an existing sanitary sewer having sufficient capacity to serve the development is less than that calculated from the formula above. Lift stations may be required when gravity service is not available. On-site wastewater system may not be used for any lot smaller than one acre.



E. If the city deems that it is not practical to connect to a sanitary sewer facility that will treat the sewage for the subdivision, then the area may be served by an approved on-site sewerage facility for the individual lots as specified in the public facilities design manual and approved by regulatory authorities having jurisdiction over such facilities. The city may require a study to make such determination.

### **5.6 Private Utility Provisions Services**

---

A. Utility companies shall submit plans, showing the extent and location of construction, to the city and receive a construction permit when constructing new overhead lines, underground lines, and upgrading existing lines within the rights-of-way, utility companies are not required to obtain a permit in the event of an emergency in order to restore service.

B. From and after the effective date of the ordinance from which this chapter is derived, all subdivision and development plats, site plans and construction plans filed and submitted to the city for approval shall provide for utility services such as electrical, gas, telephone, and cable TV utility (lateral and/or service distribution) lines and wires including, but not limited to, street lighting, to be placed underground. Existing feeder and other major transmission lines that could not practically be placed underground, as determined by the city, may remain overhead. However, an owner shall endeavor, and whenever practical, the city may require that feeder lines are placed away from traffic arteries and/or be placed underground. Whenever practical, overhead feeder lines should not be placed along both sides of the street rights-of-way. The owner shall be responsible for obtaining verification from the utility companies for easement locations and widths prior to the final approval of construction plans by the city. Any changes during construction shall be approved by the utility companies and the city.

C. Where existing overhead service or lateral/distribution utilities lines are located within the land proposed for development and the lines must be relocated to accommodate the development, the owner is responsible for relocation and placement of the lines underground.

D. All new service lines shall be placed underground.

E. In special or unique circumstances or to avoid severe hardships, the city may authorize exceptions from this requirement and permit the construction and maintenance of overhead electric utility lateral or service lines and of overhead telephone or cable TV lines and may approve any plat or site plan with such approved exceptions.

F. Where electrical service is to be placed underground, all other utilities, including circuits for street and site lighting, except street lighting standards, shall be placed underground.

G. All electrical and telephone support equipment (transformers, amplifiers, switching devices, etc.) necessary for underground installations shall be pad mounted and screened with live screening to block its view from public streets. Screening of electrical pad transformers and switching equipment shall be the responsibility and at the cost of the owner. The location and depth of the screening material must be coordinated with the utility companies to ensure that safe and efficient access is maintained to the equipment. The location of all new equipment shall be shown on all site plans and construction plans.

H. Each of the utility companies shall be responsible for developing administrative policies and cost re imbursement procedures for the installation and extension of their underground utilities. Each utility company shall have the right to charge or recover costs associated with installing underground utilities in accordance with the respective utility's tariff for service and/or line extension policy. No utility company shall be required to begin construction of underground facilities unless and until the owner of the subdivision has made arrangements with the respective utility company for payment in accordance with that respective utility's tariff for

service and/or line extension policy governing utility installations and their cost.

I. Temporary construction service may be provided by overhead electric lines and facilities without obtaining a variance or exception, provided that when the underground utility service to any portion of a subdivision is completed, such overhead electric lines, and facilities are promptly removed.

**5.7 Wastewater Tap Fees**

A. Wastewater tap fees will follow the schedule below:

<b>Wastewater Tap Fees</b>		
Residential 4" Tap	Short Side	\$825.00
	Long Side with Paved Streets	\$1,600.00
	Long Side with No Paving	\$1,000.00
Commercial/Development 6" – 8" Tap	Short Side	\$1,000.00
	Long Side with Paved Streets	\$1,750.00
	Long Side with No Paving	\$1,200.00
<b>Additional Fees (Residential 4")</b>		
Boring for Road Crossing	Taps that require a street bore no more than 50 linear feet shall incur a fee. Any bore exceeding 50 linear feet shall incur a \$20 per linear foot charge.	\$625.00
Short Tap with Removal of Asphalt and/or Concrete		\$800.00
Long Tap with No Asphalt Patch		\$575.00
<b>Additional Fees (Commercial/Development 6" – 8")</b>		
Boring for Road Crossing	Taps that require a street bore no more than 50 linear feet shall incur a fee. Any bore exceeding 50 linear feet shall incur a \$20 per linear foot charge.	\$2,400.00
Short Tap with Removal of Asphalt and/or Concrete		\$800.00
Long Tap with No Asphalt Patch		\$575.00
Sanitary Sewer Manhole installation including labor and materials (6" – 8" taps) not to exceed 8 feet in depth		\$5,500.00
Sanitary sewer line extensions, refer to boring cost per linear foot		\$35.00 LF

## **PART 6: CONSTRUCTION PLANS**

### **6.1 General**

- A. All improvements shall be designed in accordance with the City Design Criteria referenced as part of this Ordinance.
- B. Submit eight copies of complete Construction Plans, Specifications, engineering calculations, and detailed cost projections, for streets, drainage, sanitary sewers, water distribution, and any other improvements to be constructed, with the final plat. Construction Plans must be 100 percent complete at the time of submittal. Any incomplete sets of Construction Plans shall be returned unreviewed.
- C. The Construction Plan fee includes the first plan review and the second review. If subsequent plan reviews are required, the developer will compensate the City for review costs.
- D. Construction Plans shall be submitted on standard 24" x 36" sheets.
- E. Each sheet of the Construction Plans shall contain a title block, including space for the notation of revisions. This space is to be completed with each revision to the plan sheet and shall clearly note the nature of the revision and the date that the revision was made.
- F. Each sheet shall bear the seal and signature of the Licensed Professional Engineer in the State of Texas who prepared the plans. In cases where City of Dayton Standard Details are implemented, the design engineer shall be responsible for all components of the details proposed.
- G. Each sheet of the Construction Plans shall include north arrow, scale, date, benchmark description to sea level datum, boundary lines and nearest street intersections, and right-of-way widths. Scales shall be one inch equal 20, 40 or 50 feet horizontally and 1-inch equals 2, 4, or 5, feet vertically.
- H. Construction plans will include a sheet with the current version of Dayton General Notes.

### **6.2 Street Improvement Plans**

- A. The Construction Plans shall include a plan and profile of each street with stationing every 100 feet, top of curb grades, and existing and proposed ground lines. The typical cross-section of proposed streets shall show the width of roadway, pavement type, and location and width of sidewalks, walkways, bike trails, and other improvements. Plans and specifications shall conform to the Design Criteria.
- B. Two (2) copies of the geotechnical report recommendations for pavement thickness and cement or lime content, as required by the Design Criteria, shall be submitted with the Construction Plans.

### **6.3 Sanitary Sewer and Water Plans**

- A. The Construction Plans shall include a plan and profile of proposed sanitary sewers, with stationing, grades and pipe sizes indicated and showing locations of manholes, etc., and a plan of the proposed water distribution system showing pipe sizes and location of valves, fire hydrants, and fittings, etc., in conformance with the Design Criteria. The City may require the Developer to perform a capacity analysis of the water and/or sewer system.

### **6.4 Site and Paving Plans**

- A. The Construction Plans shall include the following information:

1. Location and type of all proposed pavement.
2. Dimensions of all sidewalks, paving areas, parking bays, and driveways. A dimension showing the distance from the closest building corner to the property boundary shall be included.
3. Location and identification of all proposed site improvements, including but not limited to buildings, curb and gutter, accessible parking and ramps, sidewalks, striping, hydrants, dumpster enclosures, landscape areas, sawcut lines, curb cuts, and wheel stops.
4. Location and identification of significant existing features, including but not limited to hydrants, railroads, buildings, structures, drainage outfalls, channels, and streets.
5. Location and identification of all existing and proposed easements and setbacks.
6. Property boundaries with bearing and distance.
7. Lot, block, and subdivision information.
8. Building usage and square footage for each proposed building.
9. Parking analysis table showing a breakdown of land use, required parking, and proposed parking. Required and proposed parking shall include accessible spaces.

## 6.5 Drainage Plans

---

A. The Construction Plans shall include a minimum of, but not limited to, the following information:

1. Existing and proposed floodplain and floodway limits, including latest FEMA floodplain information.
2. Existing channel information
3. Area to be removed from the floodplain or area to be altered;
4. Top and toe of fill and/or side slopes and the numerical slope of the fill and/or side slopes labeled;
5. Location of all other associated improvements or alterations to creeks and/or floodplains, such as check dams, swales, channel modifications, etc.;
6. Location of all other drainage-related improvements, including but not limited to inlets, storm sewers, culverts, detention basins, outlet control devices, and emergency overflow structures. Applicable hydraulic calculations shall be provided for all proposed drainage improvements listed in this section;
7. Location of all existing and proposed easements and dedications;
8. For developments with proposed detention basins, the following information is required: detention volume calculations, stage storage tables, and cross-sections of ponds, outfalls, and overflow structures.
9. Pond cross-sections. Pond cross sections shall, at a minimum, contain the following information: 2-, 10-, and 100-year water surface elevations, pond side- and bottom-slopes, and top of bank and bottom of pond elevations.

B. Storm sewers. For developments with proposed storm sewers, the following information is required:

1. Locations, types, sizes, finished grade elevations, and connecting pipe invert elevations of all collection basins and inlets;
2. Lengths, sizes, slopes, and materials of all pipes
3. Invert elevations at the outfall location of the storm sewer system.

## 6.6 Grading Plans

---

A. The Construction Plans shall include a minimum of, but not limited to, the following information:

1. Existing contours of the land (topography) at intervals no greater than one-foot.
2. Proposed contours of the land at intervals no greater than one-foot.
3. Grading spot elevations for all parking areas, sidewalks, and driveways at intervals no greater than every 100 feet. Spot elevations shall be provided at all property boundaries at intervals no greater than every 150 feet showing proposed grade matching existing conditions. Spot elevations shall also be provided at all drainage collection basin locations, high points, accessible ramps, and locations where driveways connect with existing streets. For driveway connections with existing streets, spot elevations shall be required at each curb return.
4. Single-family residential lot grading. For all single-family developments, an exhibit showing proposed lot grading shall be included in the Construction Plans. This exhibit shall include, but is not limited to: location and dimensions of lot lines and pads, front- and rear-yard slopes, swales, and finished pad elevations.
5. Slopes. Longitudinal and cross-slope information shall be provided on all walking paths at intervals not to exceed 100 feet. Slope information is also required in all areas where grade exceeds 15 percent.
6. Finished floor elevations. Finished floor elevations are required for all proposed buildings and shall be shown to the nearest hundredth of a foot (0.01').
7. House location, address, lot and block number and subdivision.
8. Limits of clearing and grading.
9. Easements (existing and proposed; for existing easements, provide deed book and page number).
10. Property boundaries with bearing and distance.
11. Floodplain limits, if present.
12. Two printed copies of the grading plan and one portable documents format (pdf) copy of the plan shall be submitted to the designated official with the grading permit application. Five printed copies and one pdf copy of the approved grading plan shall be submitted before the grading permit is issued.

## 6.7 Erosion and Sediment Control Plans

---

A. The Construction Plans shall include a minimum of, but not limited to, the following information:

1. Existing contours of the land (topography) at intervals no greater than one-foot.
2. Proposed contours of the land at intervals no greater than one-foot.
3. Limits of clearing and grading.
4. Property lines with bearing and distance.
5. Proposed construction entrance and access road. Distance from structure corners to property lines (set back information).
6. A sequence of construction of the development site, including stripping and clearing; rough grading; construction of utilities, infrastructure, and buildings; and final grading and landscaping. Sequencing shall identify the expected date on which clearing will begin, the

estimated duration of exposure of cleared areas, areas of clearing, installation of temporary erosion and sediment control measures, and establishment of permanent vegetation.

7. All erosion and sediment control measures necessary to meet the objectives of this regulation throughout all phases of construction and after completion of development of the site. Depending upon the complexity of the project, the drafting of intermediate plans may be required at the close of each season.

8. Seeding mixtures and rates, types of sod, method of seedbed preparation, expected seeding dates, type, and rate of lime and fertilizer application, and kind and quantity of mulching for both temporary and permanent vegetative control measures.

9. Provisions for maintenance of control facilities, including easements and estimates of the cost of maintenance.

10. A concrete wash out shall be located within one hundred (100) feet of the construction entrance with a sign.

11. Modifications to the plan shall be processed and approved or disapproved in the same manner as according to the procedures in this document may be authorized by the designated official by written authorization to the permittee, and shall include:

12. Major amendments of the erosion and sediment control plan submitted to the designated official.

13. Field modifications of a minor nature.

14. Two printed copies of the erosion and sediment control plan and one Adobe portable documents format (pdf) copy of the plan shall be submitted to the designated official with the grading permit application. Five printed copies and one pdf copy of the approved grading plan shall be submitted before the grading permit is issued.

### **6.8 Plan and Profile Sheets**

---

A. Draw plan and profile sheets to the following scales:

1. Horizontal Scale: 1-inch to 40-feet
2. Vertical Scale: 1-inch to 4-feet

B. Show existing ground and proposed ground surfaces with labels Show flowlines of all pipes including labeled distances between crossing items.

### **6.9 Detail Plans**

---

A. Shall contain all design details accompanying the above set of construction plans. Such plans shall include City of Dayton Standard Details where applicable.



**PART 7: PERMITS**

**7.1 Construction Permits**

A. Permits are required for the following construction activities as described herein:

1. Public improvements (construction permit)
2. Retaining walls
3. Curb cuts or modification of existing curbs in any way.
4. Driveways
5. Private ponds
6. Floodplain reclamation
7. Site grading (grading permit)
8. Water wells
9. Screening walls
10. Sidewalks
11. Trench cuts and other construction in city rights-of-way
12. Road Use Agreement (Appendix A)

B. Permits applications shall be reviewed and approved by the designated official as described in various sections of this chapter. Construction of any of the above shall not begin until a permit has been obtained.

C. The City Council shall, from time to time, establish permit fees and such fees shall be paid by the owner before the permit is processed or approved.

D. The City Council has established impact fees and such fees shall be paid by the owner before the permit is processed or approved. Effective May 17, 2022, water and wastewater impact fees will be assessed as follows:

Meter Size	Service Unit Equivalent	Impact Fees	
		Water	Wastewater
3/4"	1.0	\$4,504	\$6,595
1"	1.7	\$7,507	\$10,992
1-1/2"	3.3	\$15,013	\$21,983
2"	5.3	\$24,021	\$35,173
3"	11.7	\$52,547	\$76,942
4"	20.0	\$90,080	\$131,900
6"	45.0	\$202,680	\$296,775
8"	53.3	\$240,213	\$351,733

## PART 8: CONSTRUCTION AND INSPECTION

### 8.1 General

- A. A preconstruction conference shall be required prior to start of any construction. The meeting shall include the Developer and/or Contractor(s), Director of Public Works, City Engineer, Developer's Engineer, and City Inspector(s). Only one preconstruction conference will be held.
- B. If the Developer has divided the construction of the public improvements among more than one contractor, the Developer shall designate one person to represent all the construction for the development.
- C. A I shall be submitted whenever traffic is disrupted as defined in the latest version of the Texas Manual on Uniform Traffic Control Devices. It shall be submitted and approved by the City Engineer prior to the start of any construction.
- D. Prior to beginning construction, Contractor shall submit the following to the Director of Public Works:
1. Construction Schedule
  2. Permits
  3. Shop Drawings and Material Submittals.

### 8.2 Inspection

- A. All construction, such as street grading, street paving, drainage structures, curb and gutter, storm sewers, sanitary sewers, and water mains, shall be subject to inspection during the construction period by the proper authorities of the City, and shall be constructed in accordance with the approved Construction Plans and City Design Criteria.
- B. During the progress of the work, all materials, equipment and workmanship shall be subjected to such inspections and tests as will assure conformance with the City requirements. All testing shall be done by a testing laboratory approved by the City. The City shall select the location of all testing. The contractor shall pay for all testing. The Contractor shall furnish at its expense all necessary specimens and samples for testing. The Contractor is solely responsible for coordination with the testing laboratory, for scheduling of the tests, and for timely delivery of the results to the Director of Public Works. Any results not meeting the specifications will require additional tests and inspections paid for by the contractor. The City Inspectors and City Engineer will determine the additional testing and extra inspection required to ensure conformance with City requirements.
- C. The Contractor shall only be allowed to work on Saturdays when approved by the City. A written request must be submitted to the City three days in advance. If approved, work can only occur between 9:00 a.m. and 5:00 p.m. The Contractor shall pay the City's Inspector services at time and a half. No work will be allowed on Sundays.
- D. A traffic control plan shall be submitted whenever traffic is disrupted as defined in the latest version of the *Texas Manual of Uniform Traffic Control Devices for Streets and Highways* by the Texas Department of Transportation. It shall be held 72 hours prior to interruption.

### 8.3 Final Inspection

- A. Upon completion of the construction, the Developer shall request a final inspection of the work. The City Inspector, the Director of Public Works, the City Engineer, and a Contractor's Representative shall perform a final inspection. If the Developer has divided the construction of

the public improvements among more than one Contractor, the Developer shall designate one person to represent all of the construction for the development. There will be only one final inspection of the development. The cost for performing additional inspections shall be paid by the Developer.

B. The City Engineer shall prepare a list of items that need to be completed prior to the final acceptance of the project.

#### **8.4 Record Drawings**

---

A. The Developer shall provide two (2) sets of full-size 24" x 36" (hard copy) record drawings, one set of good quality full-size reproducible record drawings, and one (1) electronic copy as AutoCAD DWG file and one (1) Adobe PDF file. The record drawings must be revised by the Developer to reflect all revisions to the original plans during construction. The record drawings must be approved by the City Engineer prior to the final acceptance of the subdivision. The record drawings shall include a copy of the approved final plat.

#### **8.5 Acceptance By The City**

---

A. Project will not be accepted by the City until all bills, including review fees, have been paid.

B. Contractor will provide affidavit of final payment and release of liens.

C. Contractor will provide two-year maintenance bonds for all public infrastructure.

D. Once all the requirements of the City have been met, the City Engineer shall recommend acceptance of the subdivision in the form of a letter to the Director of Public Works.

E. Acceptance by the City shall be in the form of a letter from the City Engineer or other authorized City Official to the Developer. The letter must state that inspections were conducted, and the facilities were completed in accordance with the specifications and standards provided for herein or approved by the City Council at the time the final plat was approved for the said subdivision.

#### **8.6 Issuance of Building Permits**

---

A. No building permit, water, sanitary sewer, plumbing or electrical permit or service shall be issued or allowed to a Developer, Owner or any other person with respect to any property in any subdivision, except for model homes and construction offices, covered by this Ordinance until such time as all of the applicable requirements of this Ordinance have been satisfactorily completed and the construction accepted by the City and the final plat is filed with the County.

**PART 9: LIST OF APPROVED EQUIPMENT MANUFACTURERS**

A. The City of Dayton’s Standard Product List has been developed to minimize the submittal review of products which meet the city’s Design Standards and Details during development and construction projects. When Technical Specifications for specific products are included as part of the Construction Contract Documents, the requirements of the Technical Specification will override. Requests for substitution must be evaluated and approved by the committee prior to material purchase.

B. Reference on this list does not relieve the sealing engineer of the responsibility to select the equipment appropriate for the specific design or approved equal.

C. The following table represents the manufacturers and equipment models which have been pre-qualified:

Category	Item	Manufacturer	Model	Note	Date Approved
Roadway	General Concrete Repair	FlexKrete Technologies		Vinyl Polyester Repair Product Misc. Use	8 2019
Wastewater	Composite MH Frame & Cover	Composite Access Products (McCain Waterworks)		24", 26", 32.5", & 39". H-20 Rated, AASHTO M-306-10	8 2019
Wastewater	DI Manhole Ring and Cover	East Jordan Iron Works	V1432-2 and V1483 Designs	30" Dia., AASHTO M306-04	8 2019
Wastewater	DI MH Ring and Cover (Hinged & Lockable)	East Jordan Iron Works	ERGO XL Assembly with Cam Lock/MPIC/T-Gasket	30" Dia., ASSHTO M105 & ASTM A536	8 2019
Wastewater	Precast Concrete Manhole	Park Equipment			8 2019
Wastewater	Precast Concrete Manhole	Oldcastle Precast Inc		I.D. Manhole w/ 24" Cone 48" Dia. w/ 24" Ring, ASTM C 478	8 2019
Wastewater	Precast Concrete Manhole	Forterra		48" Dia., ASTM C 478	8 2019
Wastewater	Manhole Rehab System (Liner)	Sewper Coat		Protective lining for new and existing structures	8 2019

Category	Item	Manufacturer	Model	Note	Date Approved
Wastewater	Manhole Rehab System (Liner)	Poly-triple Technologies		ASTM D5813 MH repair product to stop infiltration	8 2019
Wastewater	Manhole Rehab Systems	Sprayroq	Spray Wall Polyurethane Coating	ASTM D639/D790	8 2019
Wastewater	Coating for Corrosion Protection (Exterior)	Sherwin Williams	RR&C Dampproofing Non-Fibered Spray Grade (Asphatic Emulsion)	For Exterior Coating of Concrete Structures Only	8 2019
Wastewater	Manhole Insert	Knutson			8 2019
Wastewater	Manhole Insert	Southwestern Packing & Seals, Inc	LifeSaver – Stainless Steel	For 24" Dia., ASTM D 1248	8 2019
Wastewater	Manhole Adjustment Rings	Ladtech, Inc (McCain Waterworks)	HPDE Adjustment Ring	Non-traffic area	8 2019
Wastewater	Interior Ductile Iron Pipe Coating	Induron	Protecto 401	Ductile Iron Pipe Only, ASTM B-117	8 2019
Wastewater	Air Release Valve	A.R.I. USA, Inc. (McCain Waterworks)	D025LTP02	2" Composite Body	8 2019
Wastewater	Combination Air Valve	A.R.I. USA, Inc. (McCain Waterworks)	D-023	2"-6" Flanged 3 – 250 psi	8 2019
Wastewater	Concrete Pipe, Reinforced	Wall Concrete Pipe Co. Inc		ASTM C 76	8 2019
Wastewater	Concrete Pipe, Reinforced	Hydro Conduit Corporation	Class III T&G. SPL Item #77	ASTM C 76	8 2019
Wastewater	Concrete Pipe, Reinforced	Hanson Concrete Products		ASTM C 76	8 2019
Wastewater	Concrete Pipe, Reinforced	Concrete Pipe & Products Co. Inc		ATM C 76	8 2019
Wastewater	PVC Sewer Pipe	J-M Manufacturing Co, Inc (JM Eagle)		4" – 15", ASTM D 3034	8 2019

Category	Item	Manufacturer	Model	Note	Date Approved
Wastewater	PVC Sewer Pipe	Diamond Plastics Corporation	SDR-26 and SD-35	4" – 15", ASTM F 789, ASTM D 3034	8 2019
Wastewater	PVC Sewer Pipe	J-M Manufacturing Co, Inc (JM Eagle)		18" – 27", ASTM F 679	8 2019
Wastewater	PVC Solid Wall Pipe	Diamond Plastics Corporation		18" – 48", PS 46 ASTM F 679	8 2019
Wastewater	Gasketed Fittings (PVC)	GPK Products, Inc	SDR 26	4"-15", ASTM D 3034 ASTM F 679	8 2019
Wastewater	Submersible Pumps and Control Panels	Flygt	Varies by design	Varies by design	8 2019
Wastewater	City's mobile generator	Ingersol-Rand Kohler	Varies by design	Varies by design	8 2019
Water	Fire Hydrant, Dry Barrel	American AVK	AVK 2780	2.5" & 4.5" nozzle	8 2019
Water	Fire Hydrant, Dry Barrel	AFC (American-Darling Valve)		AWWA C-502	8 2019
Water	Fire Hydrant, Dry Barrel	Mueller	A-423 Centurion	AWWA C-502	8 2019
Water	Fire Hydrant, Dry Barrel	Mueller	A-423 Super Centurion 200	AWWA C-502	8 2019
Water	Gate Valve, Resilient Wedged w/ no gears	American Flow Control	Series 2530 & Series 2536	30" & 36", AWWA C515	8 2019
Water	Gate Valve, Resilient Wedged	American Flow Control	Series 2520 & Series 2524 (SD 94-20247)	20" & 24", AWWA C515	8 2019
Water	Gate Valve, Resilient Wedged	American Flow Control	Series 2516 (SD 94-20247)	16", AWWA C515	8 2019
Water	Gate Valve, Resilient Wedged	American Flow Control	Series 2500 (Ductile Iron)	4" – 12", AWWA C515	8 2019
Water	Gate Valve, Resilient Wedged	American Flow Control	42" & 48" AFC 2500	42" & 48", AWWA C515	8 2019
Water	Gate Valve, Resilient Seated	Mueller Co.	3. 4.	4" -12"	8 2019

LIST OF APPROVED EQU



Category	Item	Manufacturer	Model	Note	Date Approved
Water	Gate Valve, Resilient Seated	Mueller Co.	Series A2361 (SD 6647)	16", AWWA C515	8 2019
Water	Gate Valve, Resilient Seated	Mueller Co.	Series A2360 for 18"-24" (SD 6709)	24" & smaller, AWWA C515	8 2019
Water	Gate Valve, Resilient Seated	Mueller Co.	Mueller 30" & 36", C-515	30" & 36", AWWA C515	8 2019
Water	Gate Valve, Resilient Seated	Mueller Co.	Mueller 42" & 48", C-515	42" & 48", AWWA C515	8 2019
Water	Meter Accessory	Badger	ORION Water Endpoints ORI-DS-02957-EN-06	Cellular LTE-M Endpoint	12 2021
Water	Meter	Badger	E-Series Ultrasonic ESM-DS-00675-EN-09	5/8", 5/8" X 3/4", 3/4", 1"	12 2021
Water	Meter	Badger	E-Series Ultrasonic Plus Meter with Integrated Valve	5/8" X 3/4", 3/4", 1"	12 2021
Water	Meter	Badger	E-Series Ultrasonic ESM-DS-00672-EN-09	1-1/2", 2"	12 2021
Water	Meter	Badger	E-Series G2 Ultrasonic Meters ESM-DS-02781-EN-10	3", 4"	12 2021
Water	Meter	Badger	M-Series M5000 – Electromagnetic Flow Meter	1/2" to 24"	12 2021
Water	Meter	Badger	Recordall® Fire Series Assemblies (FSAA)	4", 6", 8", 10"	12 2021
Water	PVC Pressure Pipe	Diamond Plastics Corporation	DR 14	4"-12", AWWA C900	8 2019
Water	PVC Pressure Pipe	Diamond Plastics Corporation	Trans 21, DR 14, DR 18	16"-24", AWWA C900	8 2019
Water	PVC Pressure Pipe	JM Eagle	DR 14, "Blue Brute"	4"-12", AWWA C900, UL 1285, ANSI/NSF 61, FM 1612	8 2019

Category	Item	Manufacturer	Model	Note	Date Approved
Water	PVC Pressure Pipe	JM Eagle	DR 18, "Blue Brute"	16"-24", AWWA C900, UL 1285, ANSI/NSF 61, FM 1612	8 2019
Water	Ductile Iron Pipe	Griffin Pipe Products, Co	Super Bell-tite Ductile Iron Pressure Pipe	3" - 24", AWWA C150, C151	8 2019
Water	Ductile Iron Pipe	American Ductile Iron Pipe Co	American Fastite Pipe (Bell Spigot)	4" - 30", AWWA C150, C151	8 2019
Water	Ductile Iron Pipe	American Ductile Iron Pipe Co	American Flex Ring (Restrained Joint)	4" - 30", AWWA C150, C151	8 2019
Water	Ductile Iron Pipe	US Pipe Foundry Co		AWWA C150, C151	8 2019
Water	Ductile Iron Pipe	McWane Iron Pipe Co		AWWA C150, C151	8 2019
Water	Ductile Iron Fittings	Star Pipe Products, Inc.	Mechanical Joint Fittings	AWWA C153 & C110	8 2019
Water	Ductile Iron Pipe Mechanical Restrain Joint	EBAA Iron, Inc.	Megalug Series 1100 (for DI Pipe)	4" - 42", AWWA C111/C116/C153	8 2019
Water	Ductile Iron Pipe Mechanical Restrain Joint	EBAA Iron, Inc.	Megalug Series 2000 (for DI Pipe)	4" - 24", AWWA C111/C116/C153	8 2019
Water	Mechanical Joint Retainer Glands	Star Pipe Products, Inc.	PVC Stargrip Series 4000	ASTM A536 AWWA C111	8 2019
Water	Mechanical Joint Retainer Glands	Star Pipe Products, Inc.	DIP Stargrip Series 3000	ASTM A536 AWWA C111	8 2019
Water	Double Strap Saddle	Romac	202NS Nylon Coated	AWWA C800 1" - 2" SVC, up to 24" Pipe	8 2019
Water	Double Strap Saddle	Smith Blair	# 317 Nylon Coated Double Strap Saddle		8 2019
Water	Double Strap Service Saddle	Mueller Company	DR2S Double (SS) Strap DI Saddle	AWWA C800 1" - 2" SVC, up to 24" Pipe	8 2019

Category	Item	Manufacturer	Model	Note	Date Approved
Water	Curb Stops-Ball Meter Valves	Ford Meter Box Co., Inc	FB600-7-NL, FB1600-7-NL, FV23-777-W-NL, L22-77NL	AWWA C800 2"	8 2019
Water	Curb Stops-Ball Meter Valves	Ford Meter Box Co., Inc	FB600-6-NL, FB1600-6-NL, FV23-666-W-NL, L22-66NL	AWWA C800 1-1/2"	8 2019
Water	Curb Stops-Ball Meter Valves	Ford Meter Box Co., Inc	FB600-4-NL, FB1600-4-NL, B11-444-WR-NL, B22-444-WR-NL, L28-44NL	AWWA C800 1"	8 2019
Water	Curb Stops-Ball Meter Valves	Mueller Co., Ltd.	B-25000N, B-24277N-3, B-20200N-3, H-15000N, H-1552N, H142276N	AWWA C800, ANSF 61, ANSI/NSF 372 2"	8 2019
Water	Curb Stops-Ball Meter Valves	Mueller Co., Ltd.	B-25000N, B-20200N-3, B-24277N-3, H-15000N, H-14276N, H15525N	AWWA C800, ANSF 61, ANSI/NSF 372 1-1/2"	8 2019
Water	Curb Stops-Ball Meter Valves	Mueller Co., Ltd.	B-25000N, B-20200N-3, H-15000N, H-15530N	AWWA C800, ANSF 61, ANSI/NSF 372 1"	8 2019
Water	Coated Tapping Saddle with Double SS Straps	Smith & Blair	#406 Double Band SS Saddle	1"-2" Taps up to 12"	8 2019
Water	Rectangular Black Box w/ Black Polymer Lid	DFW Plastics. Inc.	DFW1600X.12.E1M QF2 DAY		12 2021
Water	Combination Air Release Valve	GA Industries, Inc.	Empire Air and Vacuum Valve, Model 935	1" & 2", ASTM A 126 Class B, ASTM A 240 – float, ASTM A 307 – Covered Bolts	8 2019
Water	Water Sampling Station	Water Plus	B20 Water Sampling Station		8 2019

## **PART 10: STANDARD CONSTRUCTION DETAILS**

Including the City of Dayton Standard Construction Detail in plans does not relieve the sealing engineer of the responsibility for the specific design. These details should be considered minimum standards which the sealing engineer may modify to meet site specific design requirements.

Sheet Number	Sheet Title		
		S12	Sanitary Manhole Cover
		S13	Sewer Sentry Device
G00	Detail Index	D01	Curbed Flume
G01	Project Sign	D02	Storm Drain Curb Inlet Sheet1
G02	General Notes	D03	Storm Drain Curb Inlet Sheet 2
P01	Paving Curb & Gutter	D04	Recessed Inlet Sheet 1
P01B	Paving Curb & Gutter – 6–inch	D05	Recessed Inlet Sheet 2
P02	Valley Gutter	D06	Center Support Beam
P03	Residential Driveway	D07	Square Storm Manhole
P04	Existing Concrete Pavemenet Widening	D08	Storm Drain Inlet Lid
P05	Concrete Sidewalk	D09	Embedment Storm
P06	Construction Joint	D10	Standard Drop Inlet
P07	Expansion Joint	T01	Pavment Markings 1 of 2
P08	Rollover Curb and Gutter	T02	Pavement Markings 2 of 2
P09	Monolithic Median Type 1	T03	Road Closed Barricade
P10	Monolithic Median Type 2	T04	Sign Post
P11	Concrete Pavement Jointing Layout	T05	Stop Signs and Stop Bars
P12	Median Nose	T06	Street Name Blade_Notes
P13	Concrete Street Headers	T07	Street Name Blade
P14	Commercial Driveway Approach	W01	Thrust Block Sheet 1
P15	Typical Curb Ramp	W02	Thrust Block Sheet 2
S01	Sanitary Manhole	W03	Thrust Block Sheet 3
S02	Embedment Wastewater	W04	Vertical Thrust Block
S03	Sanitary Sewer Pressure Manhole Lid	W05	Thrust Block General Notes
S04	Sanitary Sewer Service	W06	Gate Valve
S05	Sanitary Manhole Drop Connection	W07	Fire Hydrant
S06	Waste Water Manhole Line Intersection	W08	Water Lowering at Wastewater Main
S07	Vented Type S Manhole	W09	Embedment Water
S08	Sanitary Manhole Abandonment	W10	Waterline Service Connection
S09	Wastewater Main Cleanout	W11	Waterline Fittings
S10	Sanitary Sewer Lateral	W12	Concrete Encasement
S11	Offsite Wastewater Marker	W13	Backside Tap
		W14	Reduced Pressure Zone Assembly



DAYTON TEXAS

## STANDARD CONSTRUCTION DETAIL

### DETAIL INDEX

REVISED:  
JANUARY 2022

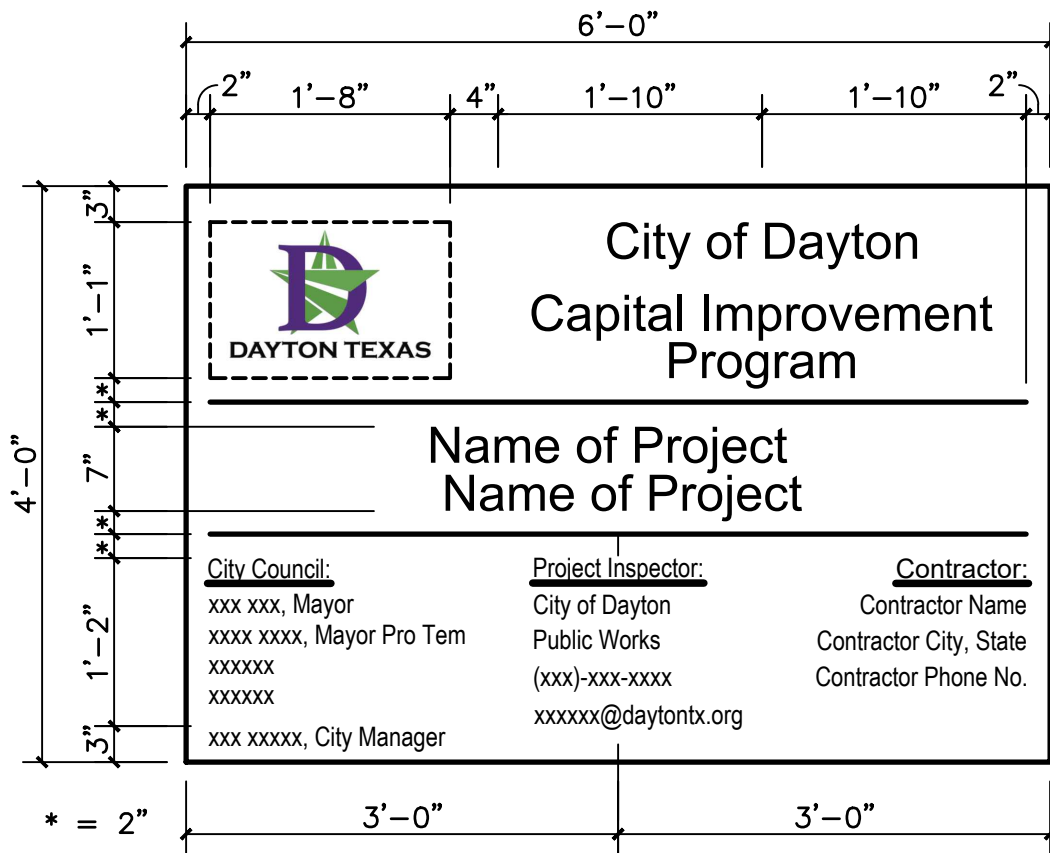

**NOTES:**

1. THIS IS A GUIDE FOR BIDDING PURPOSES
2. LOGO AVAILABLE FROM CITY OF DAYTON BY REQUEST.
3. SIGN SHALL HAVE A WHITE BACKGROUND WITH BLACK LETTERING. LETTERING (EXCEPT LOGO) SHALL BE ARIAL FONT.
4. SIGN LAYOUT SHALL BE APPROVED BY CITY PRIOR TO FABRICATION.
5. SIGN MAY BE SKID MOUNTED OR POST MOUNTED. CONTRACTOR IS RESPONSIBLE FOR REMOVING SIGN STRUCTURE AND RESTORING GROUND PRIOR TO FINAL ACCEPTANCE.

	<p><b>STANDARD CONSTRUCTION DETAIL</b></p> <p><b>PROJECT SIGN</b></p>	<p>SCALE: 3/4"=1'-0"</p> <p>REVISED: JANUARY 2022</p> <p>G01</p>
---	---	--

INCLUDING THE CITY OF DAYTON STANDARD CONSTRUCTION DETAIL IN PLANS DOES NOT RELIEVE THE SEALING ENGINEER OF THE RESPONSIBILITY FOR THE SPECIFIC DESIGN. THESE DETAILS SHOULD BE CONSIDERED MINIMUM STANDARDS WHICH THE SEALING ENGINEER MAY MODIFY TO MEET SITE SPECIFIC DESIGN REQUIREMENTS.





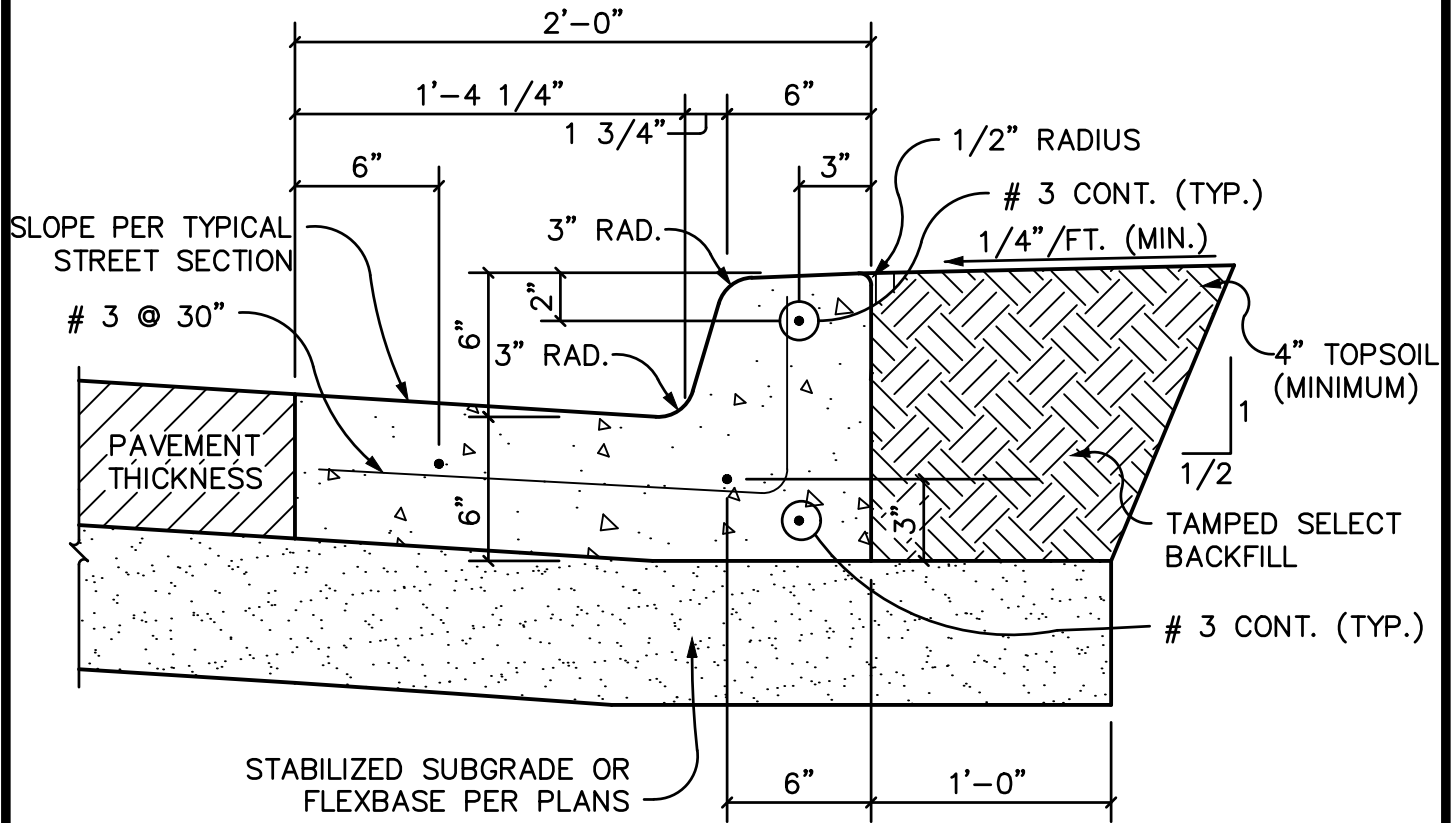

NOTE:

- 1) DEPENDING UPON CONSTRUCTION MEANS AND METHODS, L-BAR MAY BE OMITTED
- 2) PAVEMENT REINFORCEMENT SHALL BE #3 @ 18" OCEW.



STANDARD CONSTRUCTION DETAIL  
**6" CONCRETE CURB AND 18" GUTTER**

SCALE: 1"=1'-0"

REVISED:  
 JANUARY 2022

P01A

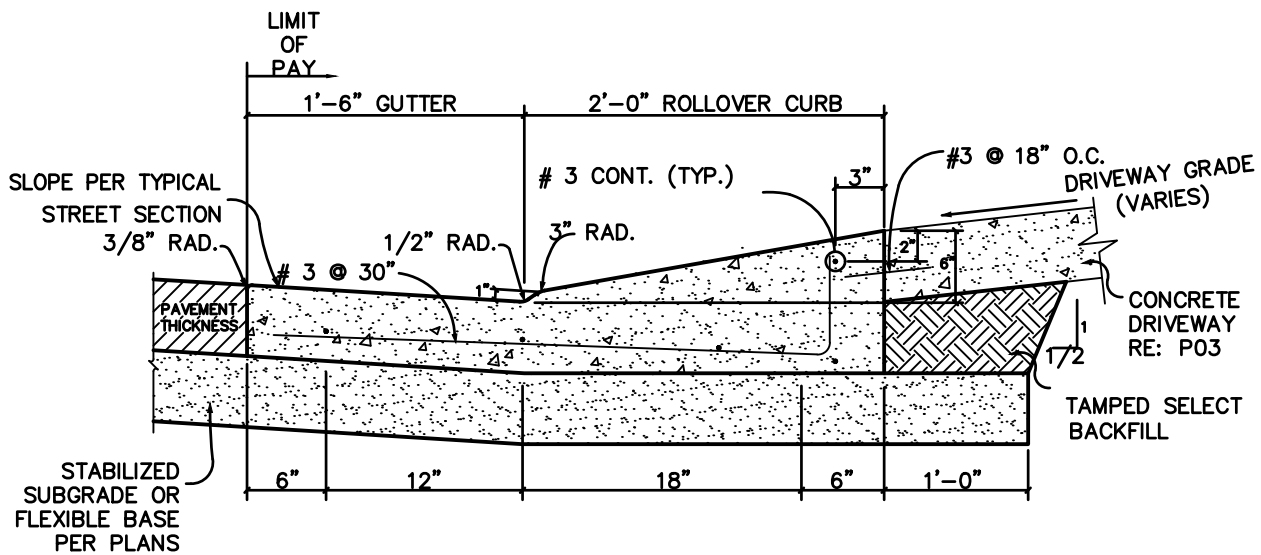

NOTES:

PAVING REINFORCEMENT SHALL BE #3 @ 18 OCEW.



STANDARD CONSTRUCTION DETAIL

6" ROLLED/LAY DOWN CURB

SCALE: 1"=1'-0"

REVISED:  
JANUARY 2022

P01B

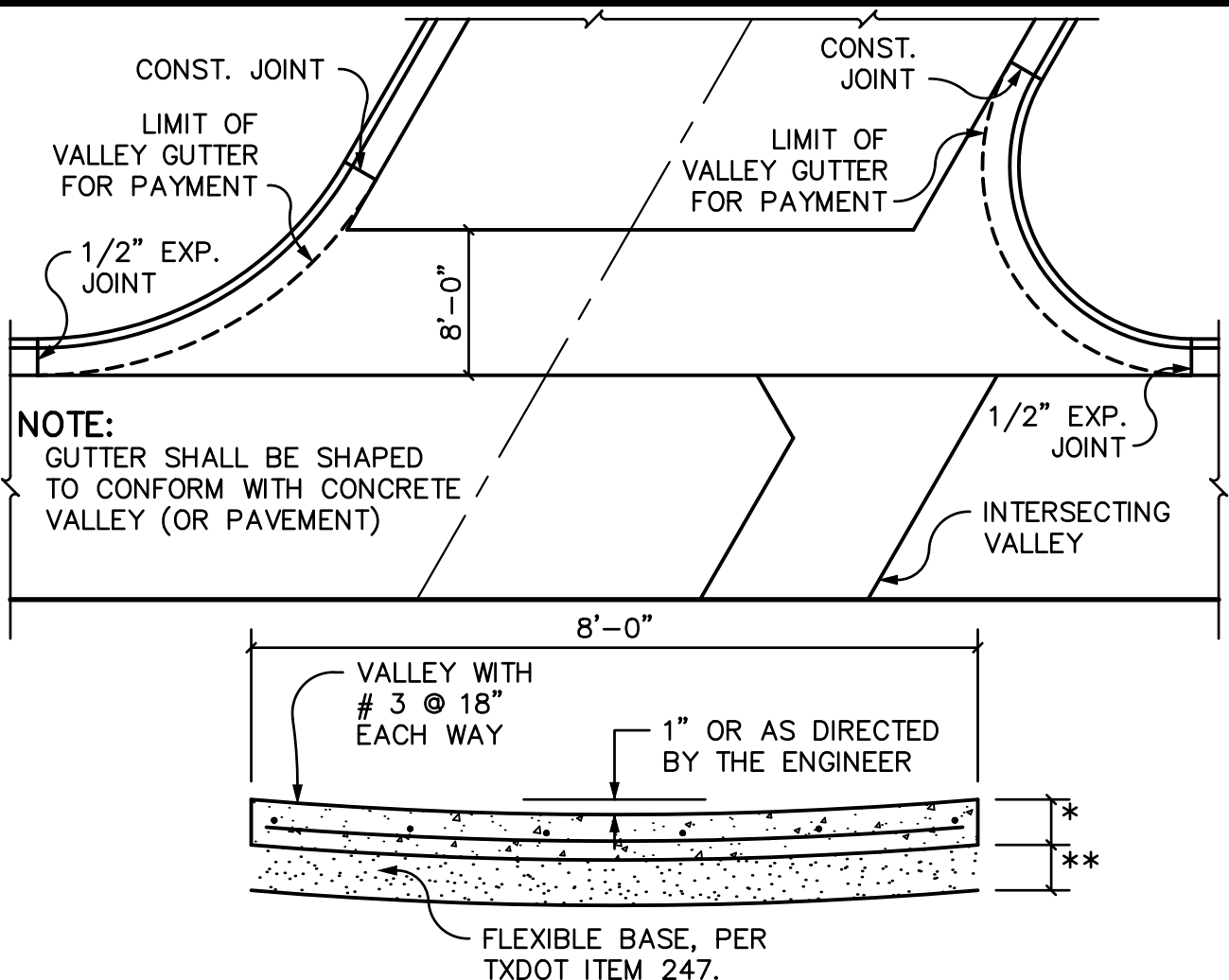

THE REINFORCED CONCRETE VALLEY SHALL REPLACE THE TOP OF THE PAVEMENT WITH THE REMAINING PORTION OF THE PAVEMENT TO BE CONSTRUCTED INCLUDING SUBGRADE TREATMENT, IN ACCORDANCE WITH THE TYPICAL PAVING SECTION. THE CONCRETE VALLEY WILL BE GOVERNED ACCORDING TO CITY STANDARDS FOR CONCRETE CURB AND GUTTER.

TRANSITION SECTION FOR VALLEYS CROSSING MAJOR STREETS	
DIST. FROM C/L OF DIP	CROWN
0 FT	0.000 FT
5 FT	0.041 FT
10 FT	0.083 FT
20 FT	0.208 FT
30 FT	0.333 FT
40 FT	0.458 FT
50 FT	0.500 FT

\* 6" FOR LOCAL STREETS  
 7" FOR COLLECTOR STREETS  
 8" FOR ARTERIAL STREETS

\*\* 8" FOR LOCAL STREETS  
 10" FOR COLLECTOR STREETS  
 10" FOR ARTERIAL STREETS

INCLUDING THE CITY OF DAYTON STANDARD CONSTRUCTION DETAIL IN PLANS DOES NOT RELIEVE THE SEALING ENGINEER OF THE RESPONSIBILITY FOR THE SPECIFIC DESIGN. THESE DETAILS SHOULD BE CONSIDERED MINIMUM STANDARDS WHICH THE SEALING ENGINEER MAY MODIFY TO MEET SITE SPECIFIC DESIGN REQUIREMENTS.

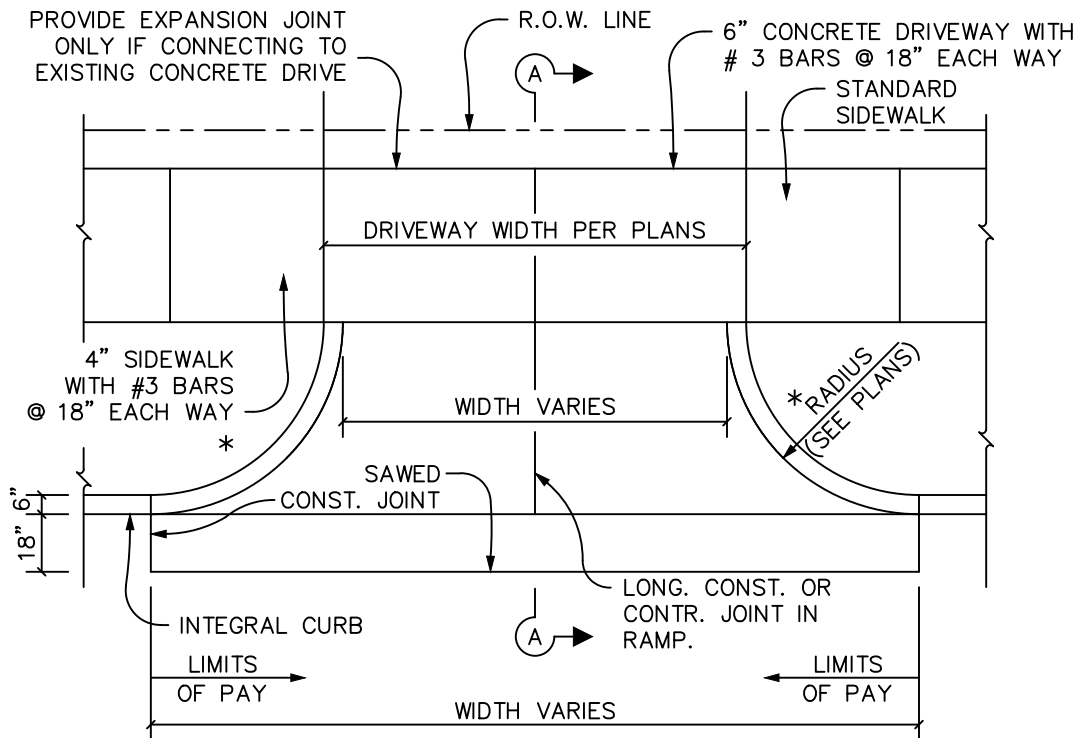

NOTE: EXISTING CURB AND GUTTER SHALL BE VERTICALLY SAWCUT. HORIZONTAL SAWCUTTING OF CURB NOT ALLOWED. REDWOOD OR FELT SHALL BE PLACED ON BOTH SIDES OF SAWED CONST. JOINT.

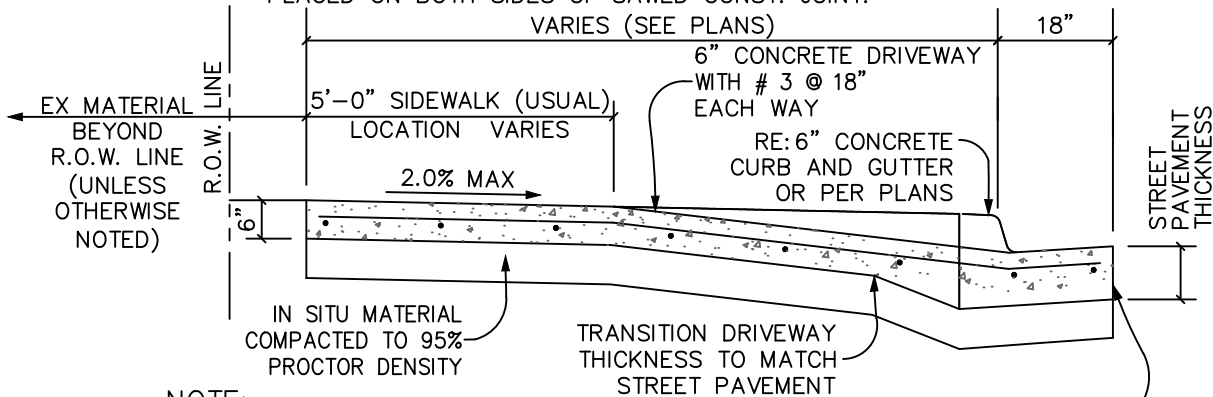

NOTE: SIDEWALK SECTION THROUGH DRIVEWAY SHALL BE POURED SAME THICKNESS AS DRIVEWAY APPROACH (EXISTING SIDEWALK, IF ANY, SHALL BE REMOVED AND REPLACED)

SECTION A-A

\* ADJUST CURB RETURN BASED UPON STANDARD CURB OR LAY-DOWN CURB.



## STANDARD CONSTRUCTION DETAIL

### RESIDENTIAL DRIVEWAY

SCALE: N.T.S.

REVISED:  
JANUARY 2022

P03

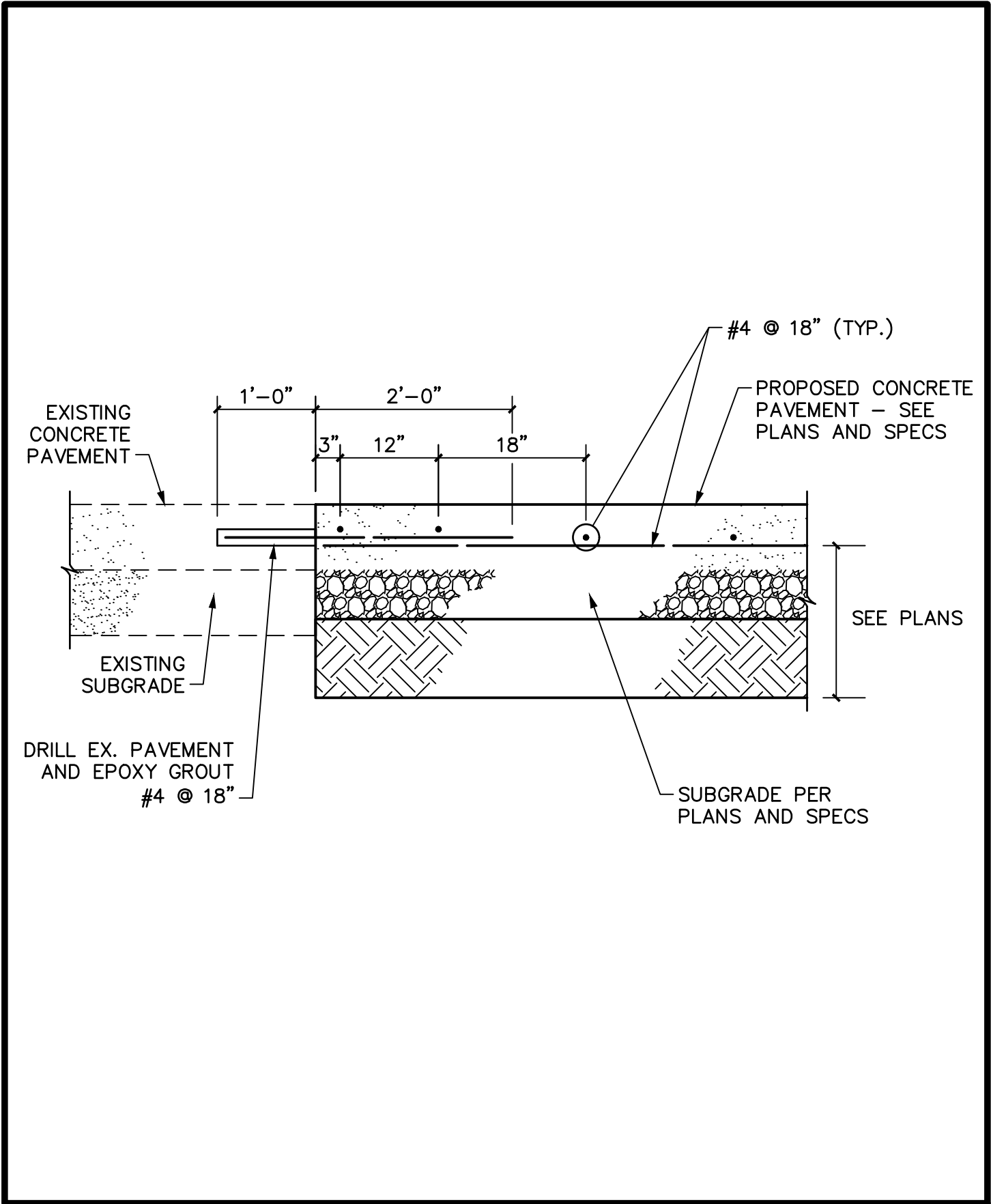

**STANDARD CONSTRUCTION DETAIL**  
**EXISTING CONCRETE PAVEMENT WIDENING**

SCALE: 3/4"=1'-0"  
 REVISED:  
 JANUARY 2022  
 P04

INCLUDING THE CITY OF DAYTON STANDARD CONSTRUCTION DETAIL IN PLANS DOES NOT RELIEVE THE SEALING ENGINEER OF THE RESPONSIBILITY FOR THE SPECIFIC DESIGN. THESE DETAILS SHOULD BE CONSIDERED MINIMUM STANDARDS WHICH THE SEALING ENGINEER MAY MODIFY TO MEET SITE SPECIFIC DESIGN REQUIREMENTS.



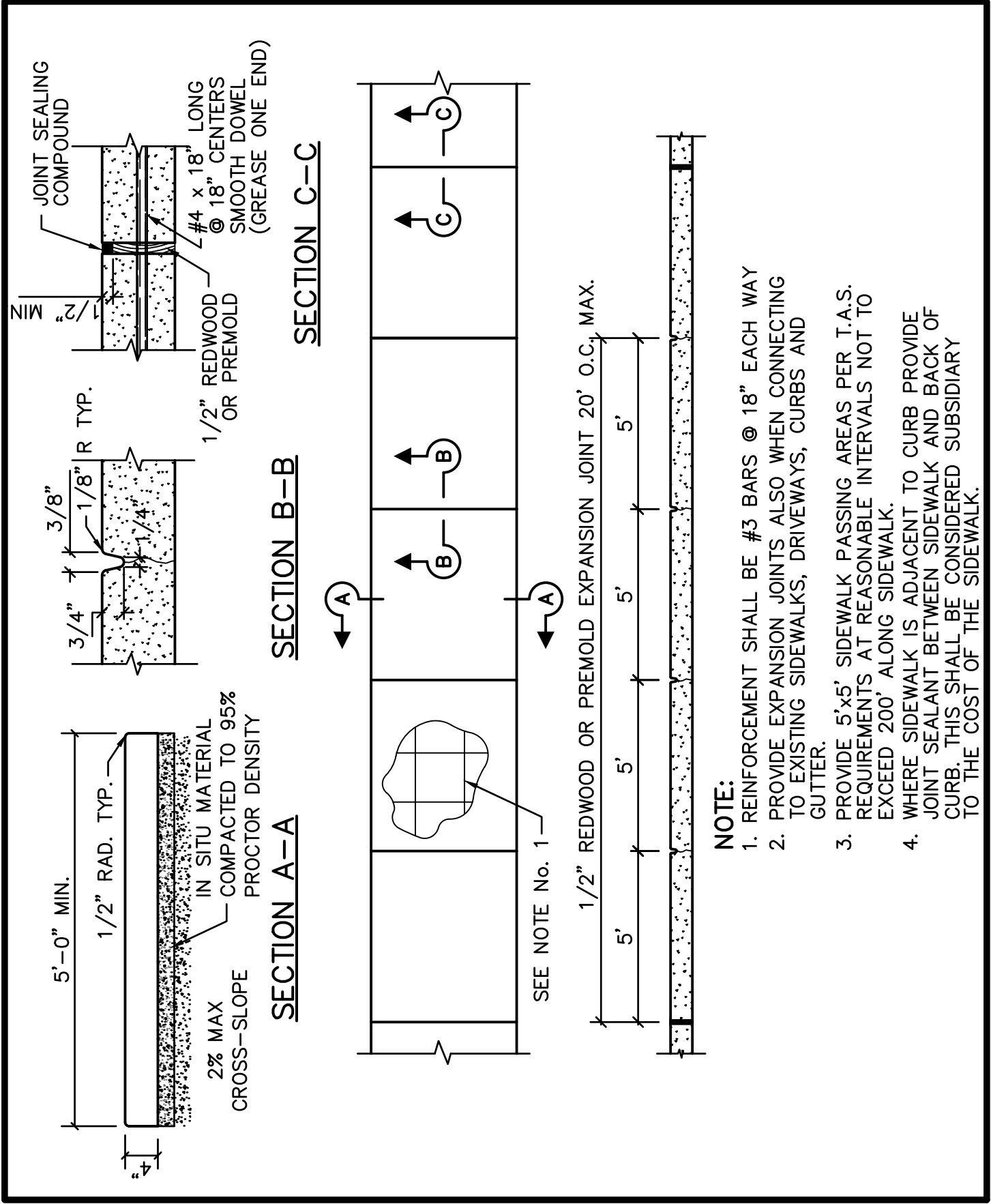

INCLUDING THE CITY OF DAYTON STANDARD CONSTRUCTION DETAIL IN PLANS DOES NOT RELIEVE THE SEALING ENGINEER OF THE RESPONSIBILITY FOR THE SPECIFIC DESIGN. THESE DETAILS SHOULD BE CONSIDERED MINIMUM STANDARDS WHICH THE SEALING ENGINEER MAY MODIFY TO MEET SITE SPECIFIC DESIGN REQUIREMENTS.

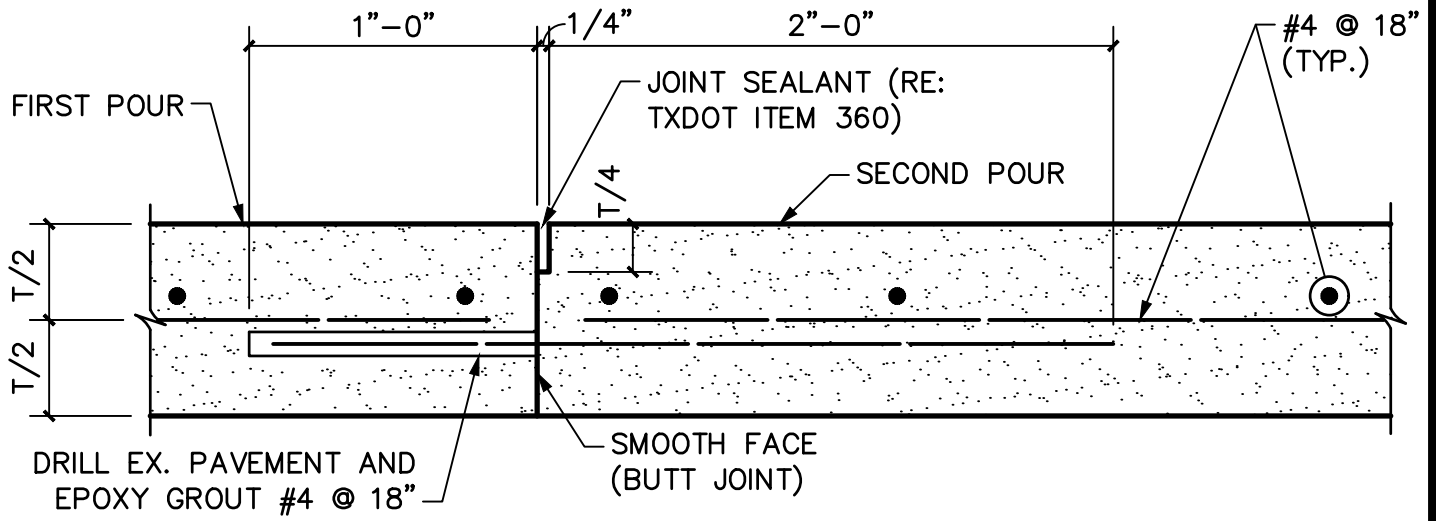

## OPTION 1

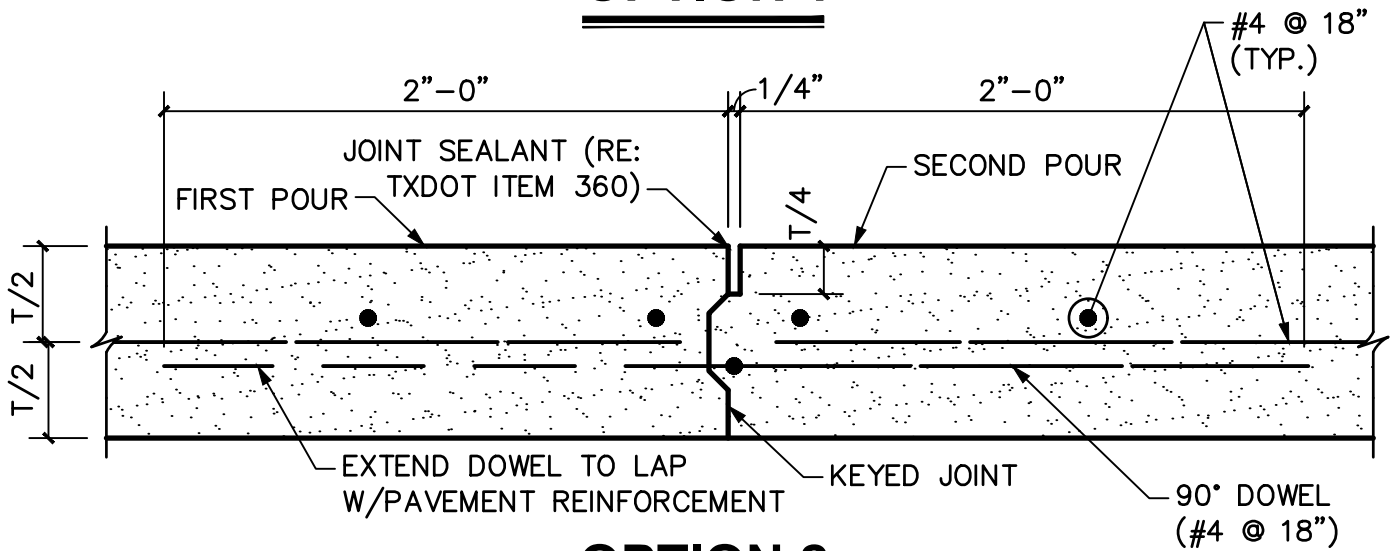

## OPTION 2

### NOTES:

1. REFER TO TXDOT ITEM 360 FOR CONCRETE PAVEMENT
2. DOWELS MUST BE INSTALLED IN THE PAVEMENT PARALLEL TO THE PAVEMENT SURFACE.
3. DOWELS IN TRANSVERSE JOINTS MUST BE INSTALLED IN THE PAVEMENT PARALLEL TO THE PAVEMENT CENTERLINE.
4. DOWELS IN LONGITUDINAL JOINTS MUST BE INSTALLED IN THE PAVEMENT NORMAL TO THE PAVEMENT CENTERLINE.
5. BACKER ROD MATERIAL MAY BE USED IN CONJUNCTION WITH SEALANT IF THE JOINT SEALANT RESERVOIR MAINTAINS AT LEAST A 1:1 WIDTH/DEPTH RATIO, BUT IN NO CASE SHALL THE RATIO BE GREATER THAN 1:15. THE BACKER ROD DIAMETER SHALL BE 1/8" GREATER THAN THE JOINT WIDTH.



## STANDARD CONSTRUCTION DETAIL CONCRETE PAVEMENT CONSTRUCTION JOINTS

SCALE: 1 1/2"=1'-0"

REVISED:  
JANUARY 2022

P06

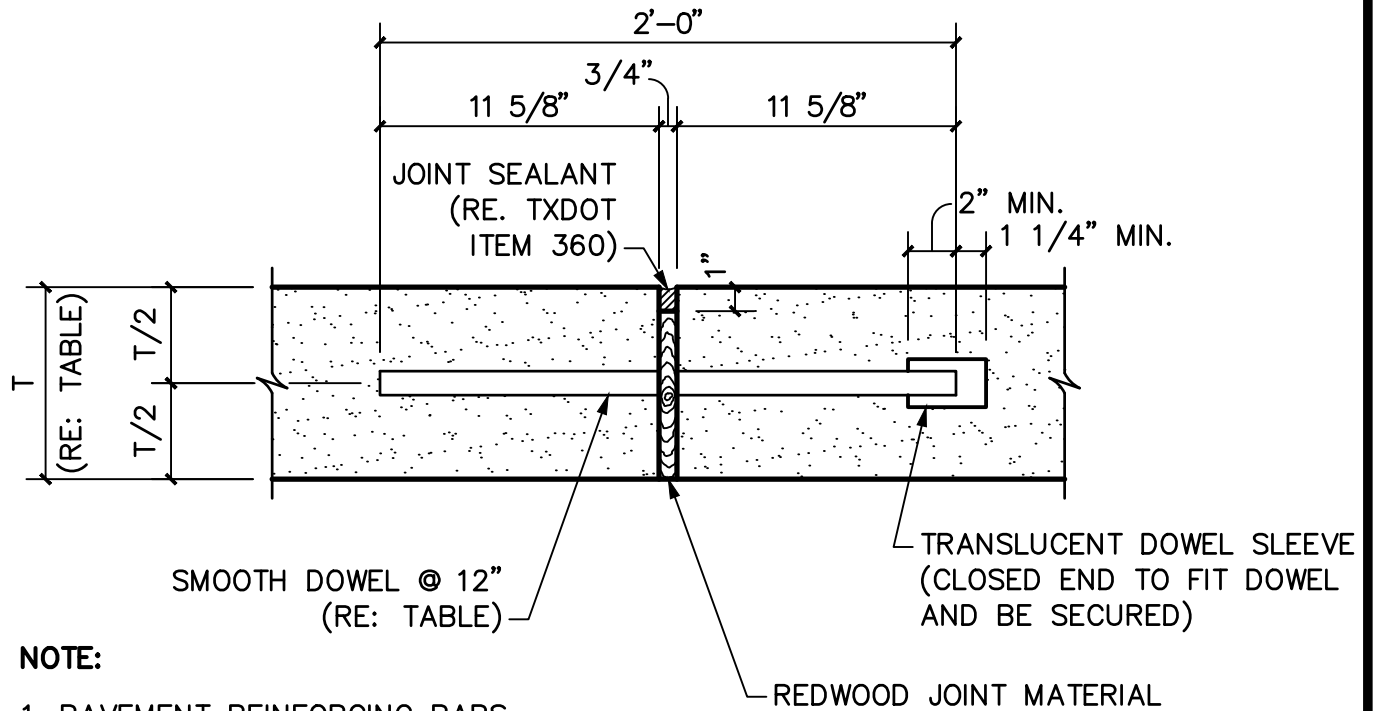

**NOTE:**

1. PAVEMENT REINFORCING BARS NOT SHOWN FOR CLARITY.

TABLE			
STREET CLASS	T (IN.)	DOWEL SIZE (IN.)	DOWEL LENGTH (L) (IN.)
A	9	1.0	24
B	8	1.0	24
C	7	0.75	24
D	6	0.75	24
E	6	0.75	24
F	6	0.75	24
G	6	0.75	24

**NOTES:**

1. REFER TO TXDOT ITEM 360 FOR CONCRETE PAVEMENT.
2. CAPPED AND UNCAPPED ENDS SHALL ALTERNATE.
3. DOWEL SUPPORT MATERIALS AND LAYOUT SHALL BE SUBMITTED TO THE CITY FOR REVIEW AND APPROVAL PRIOR TO ORDERING MATERIALS AND CONSTRUCTION.
4. ENTIRE LENGTH OF DOWEL SHALL BE LUBRICATED.
5. DOWELS MUST BE INSTALLED IN THE PAVEMENT PARALLEL TO THE PAVEMENT SURFACE AND TO THE CENTERLINE.



**STANDARD CONSTRUCTION DETAIL  
CONCRETE PAVEMENT  
EXPANSION JOINT**

SCALE: 1 1/2"=1'-0"

REVISED:  
JANUARY 2022

P07

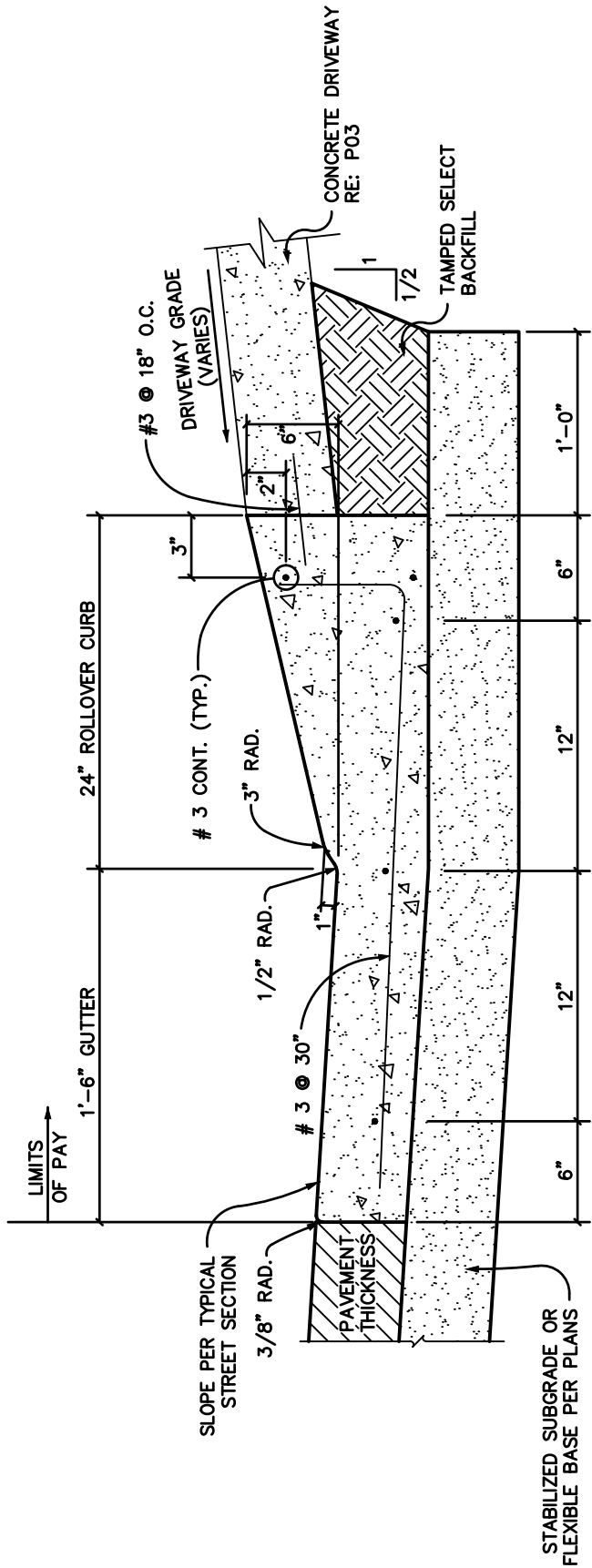

NOTES:  
PAVING REINFORCEMENT SHALL BE #3 @ 18" OCEW.



STANDARD CONSTRUCTION DETAIL  
6" ROLLOVER CURB AND 18" GUTTER

SCALE: 1"=1'-0"

REVISED:  
JANUARY 2022

P08

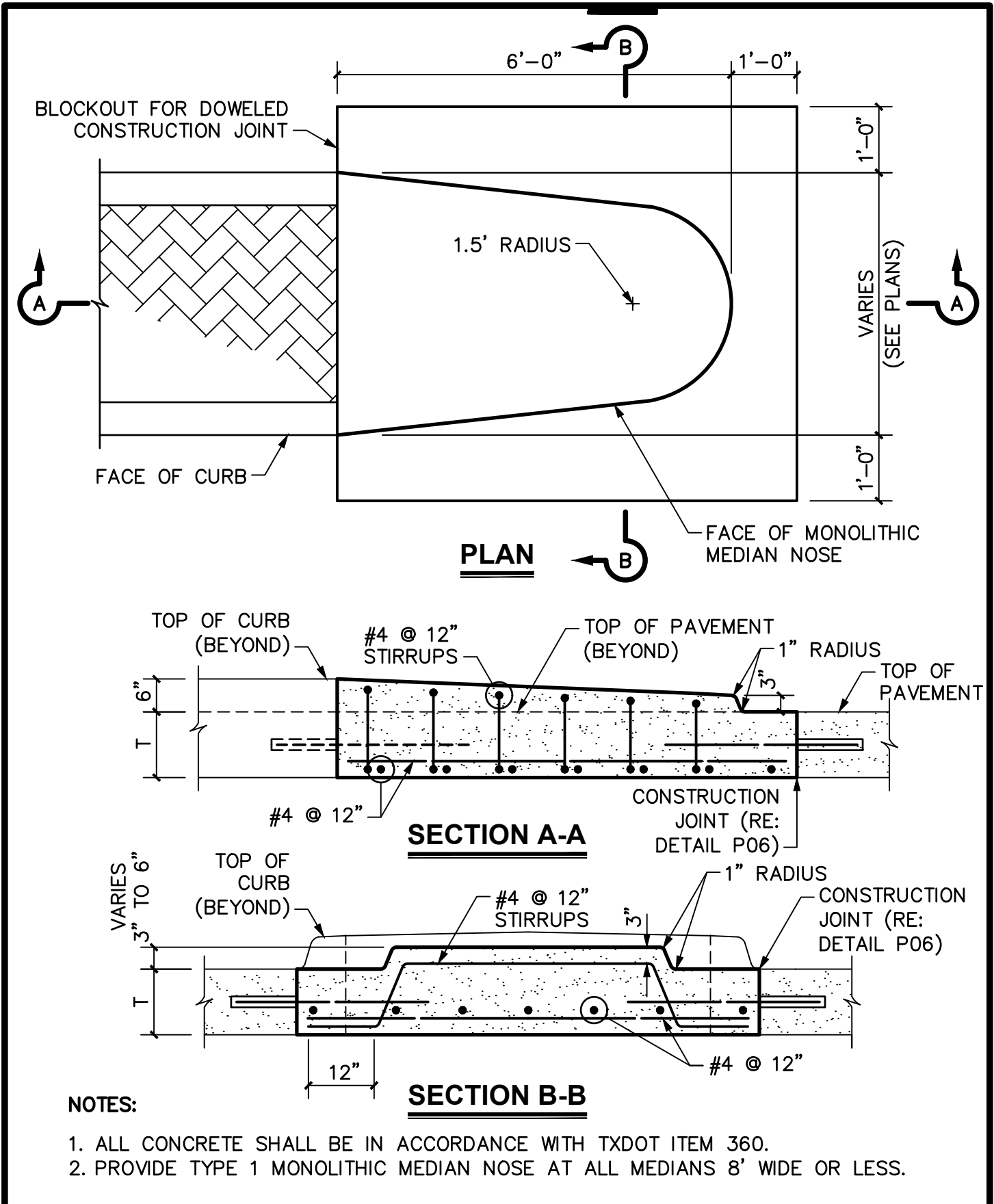

	<b>STANDARD CONSTRUCTION DETAIL</b> <b>MONOLITHIC MEDIAN NOSE</b> <b>TYPE 1</b>	SCALE: 1/2"=1'-0"
		REVISED: JANUARY 2022
		P09

INCLUDING THE CITY OF DAYTON STANDARD CONSTRUCTION DETAIL IN PLANS DOES NOT RELIEVE THE SEALING ENGINEER OF THE RESPONSIBILITY FOR THE SPECIFIC DESIGN. THESE DETAILS SHOULD BE CONSIDERED MINIMUM STANDARDS WHICH THE SEALING ENGINEER MAY MODIFY TO MEET SITE SPECIFIC DESIGN REQUIREMENTS.

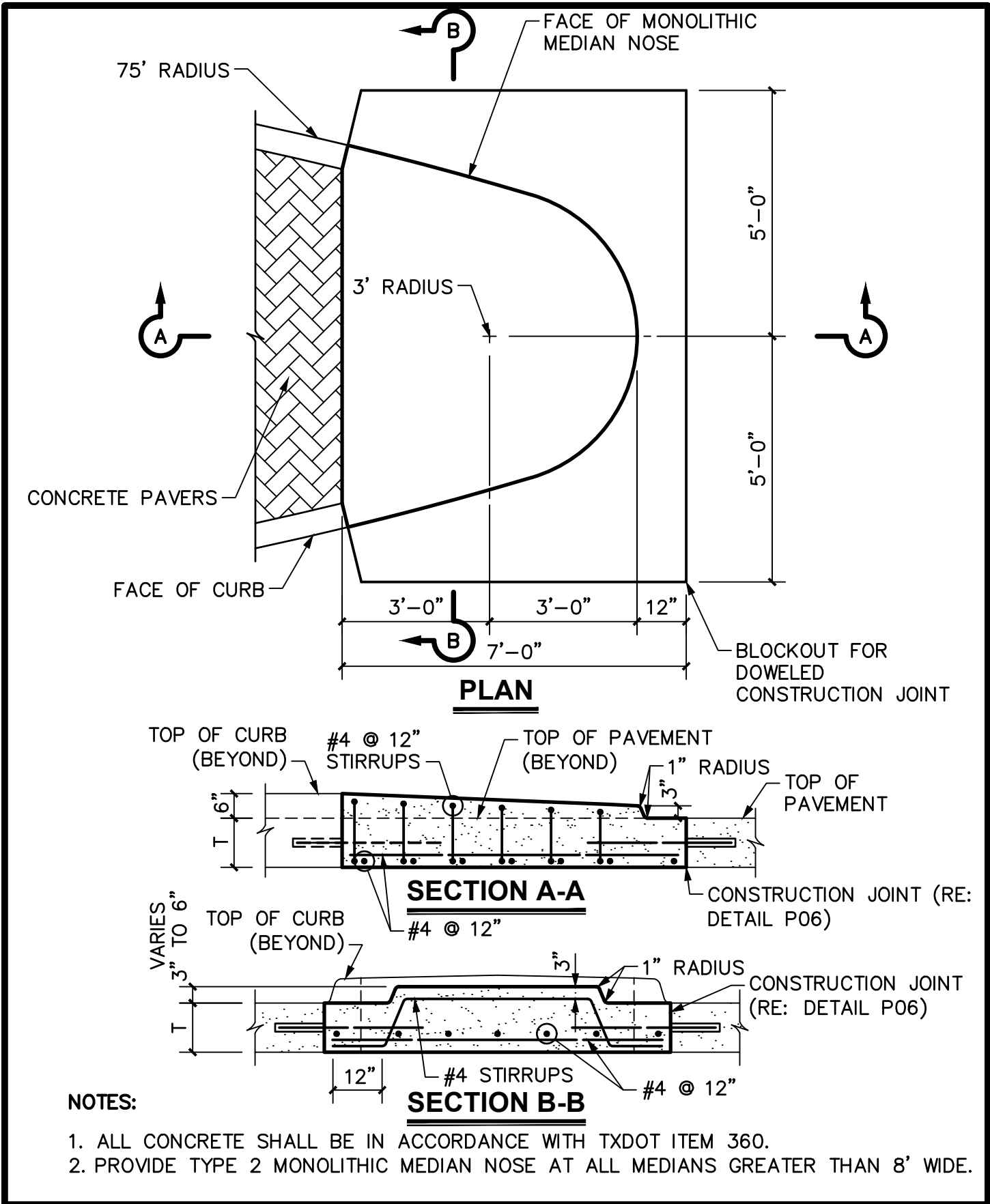

 <p>DAYTON TEXAS</p>	<p><b>STANDARD CONSTRUCTION DETAIL</b>  <b>MONOLITHIC MEDIAN NOSE</b>  <b>TYPE 2</b></p>	<p>SCALE: 3/8"=1'-0"          REVISED:          JANUARY 2022          P10</p>
---	--	---

INCLUDING THE CITY OF DAYTON STANDARD CONSTRUCTION DETAIL IN PLANS DOES NOT RELIEVE THE SEALING ENGINEER OF THE RESPONSIBILITY FOR THE SPECIFIC DESIGN. THESE DETAILS SHOULD BE CONSIDERED MINIMUM STANDARDS WHICH THE SEALING ENGINEER MAY MODIFY TO MEET SITE SPECIFIC DESIGN REQUIREMENTS.

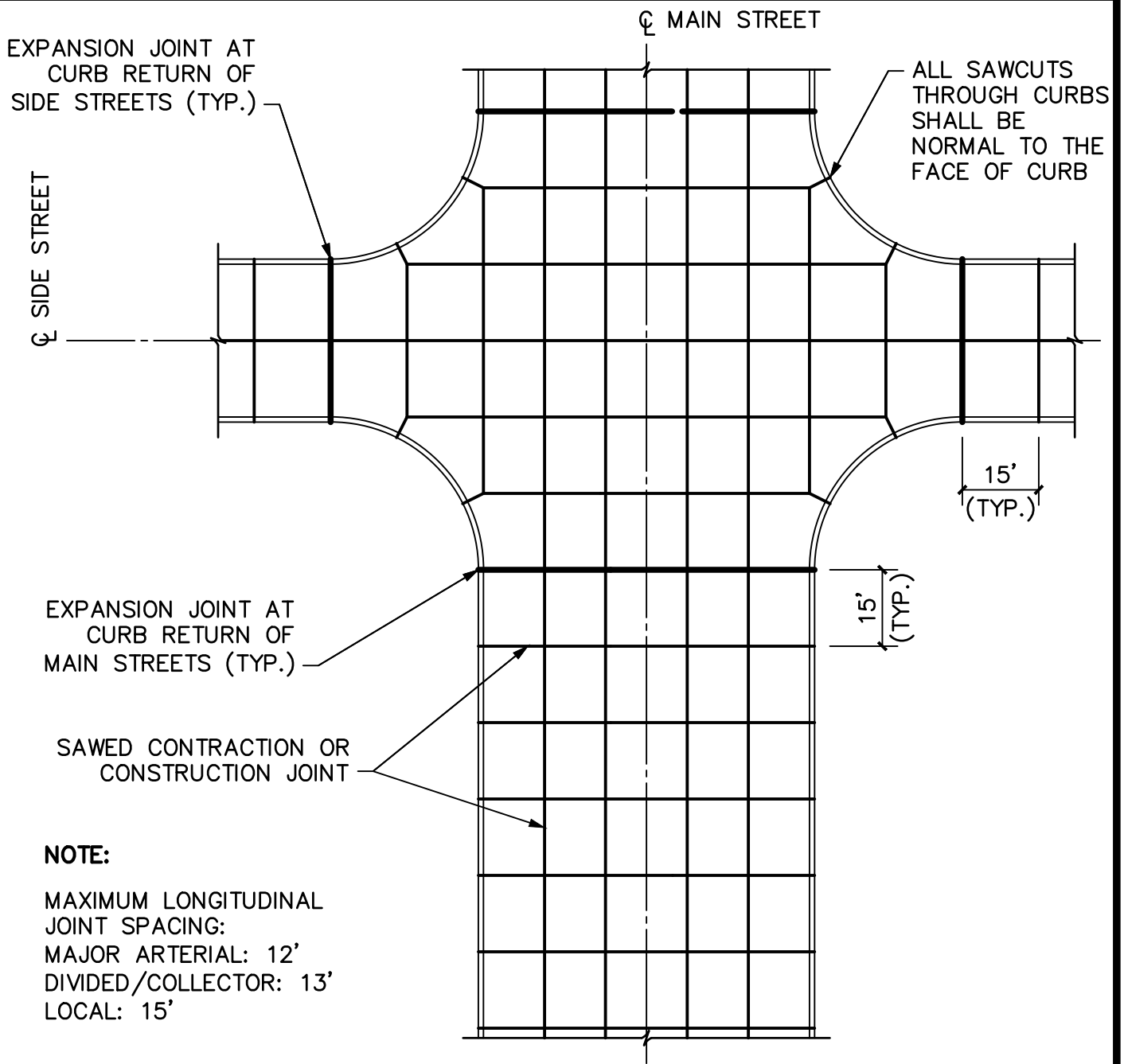

**NOTE:**

MAXIMUM LONGITUDINAL JOINT SPACING:  
 MAJOR ARTERIAL: 12'  
 DIVIDED/COLLECTOR: 13'  
 LOCAL: 15'

**NOTES:**

1. REFER TO TXDOT ITEM 360 FOR CONCRETE PAVEMENT.
2. ALL PAVEMENT JOINTS ARE EITHER SAWED CONTRACTION OR CONSTRUCTION JOINTS UNLESS NOTED OTHERWISE.
3. MAXIMUM TRANSVERSE JOINT SPACING IS 15'.
4. LONGITUDINAL JOINT SPACING SHALL MATCH LANE LINES UNLESS NOTED OTHERWISE.
5. ALL SAWCUTS SHALL BE 1/8" TO 3/16" WIDE AND ONE-FOURTH THE DEPTH OF THE ACTUAL SLAB THICKNESS.
6. ALL PAVEMENT JOINTS SHALL BE SEALED IN ACCORDANCE WITH TXDOT.

 <p>DAYTON TEXAS</p>	<p><b>STANDARD CONSTRUCTION DETAIL</b>  <b>CONCRETE PAVEMENT</b>  <b>JOINTING LAYOUT</b></p>	<p>SCALE: 1"=30'          REVISED:          JANUARY 2022          P11</p>
---	--	---

INCLUDING THE CITY OF DAYTON STANDARD CONSTRUCTION DETAIL IN PLANS DOES NOT RELIEVE THE SEALING ENGINEER OF THE RESPONSIBILITY FOR THE SPECIFIC DESIGN. THESE DETAILS SHOULD BE CONSIDERED MINIMUM STANDARDS WHICH THE SEALING ENGINEER MAY MODIFY TO MEET SITE SPECIFIC DESIGN REQUIREMENTS.



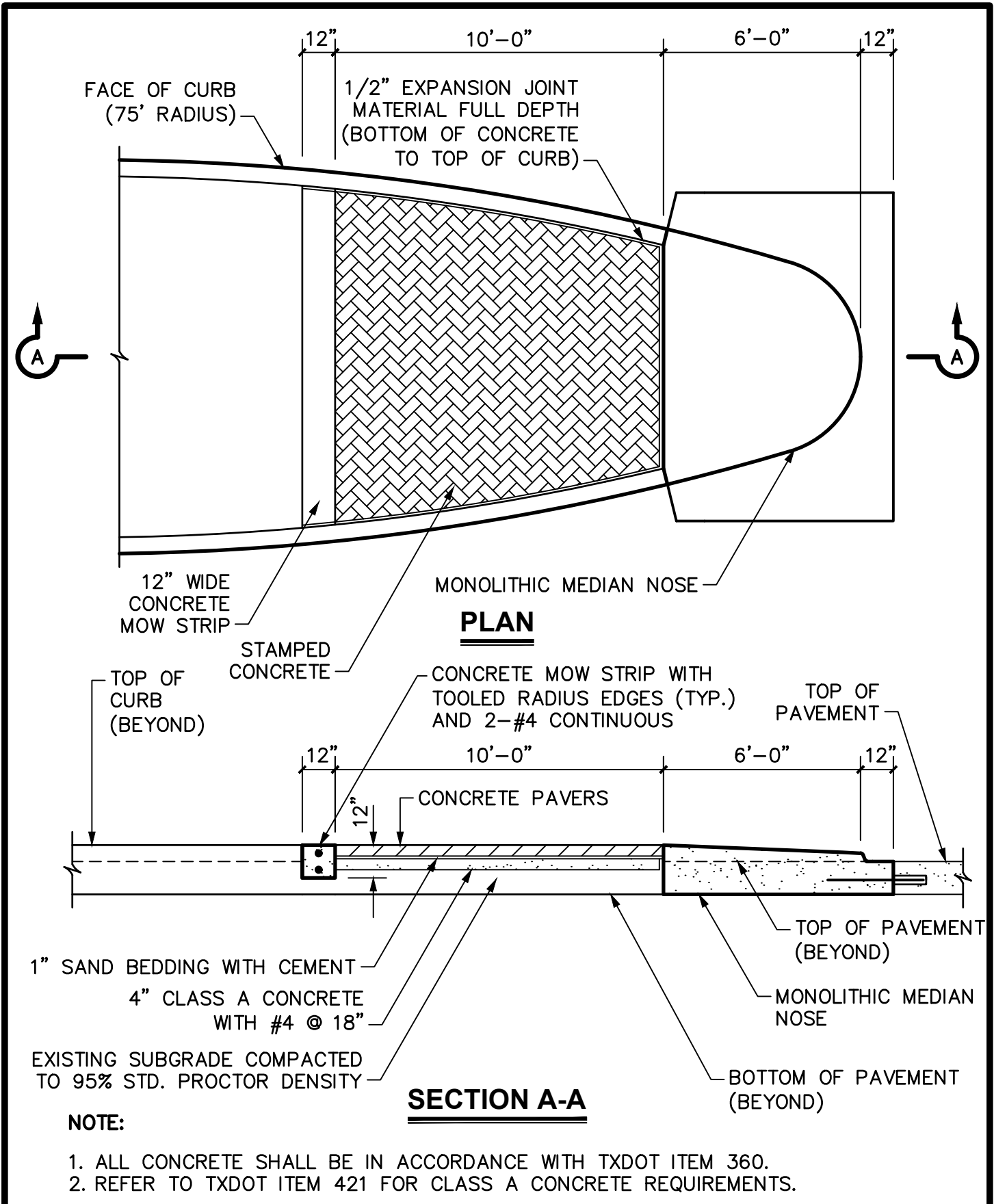

 <p>DAYTON TEXAS</p>	<p><b>STANDARD CONSTRUCTION DETAIL</b></p> <p><b>MEDIAN NOSE WITH PAVERS</b></p>	<p>SCALE: 1/4"=1'-0"</p> <p>REVISED: JANUARY 2022</p> <p>P12</p>
---	--	--

INCLUDING THE CITY OF DAYTON STANDARD CONSTRUCTION DETAIL IN PLANS DOES NOT RELIEVE THE SEALING ENGINEER OF THE RESPONSIBILITY FOR THE SPECIFIC DESIGN. THESE DETAILS SHOULD BE CONSIDERED MINIMUM STANDARDS WHICH THE SEALING ENGINEER MAY MODIFY TO MEET SITE SPECIFIC DESIGN REQUIREMENTS.

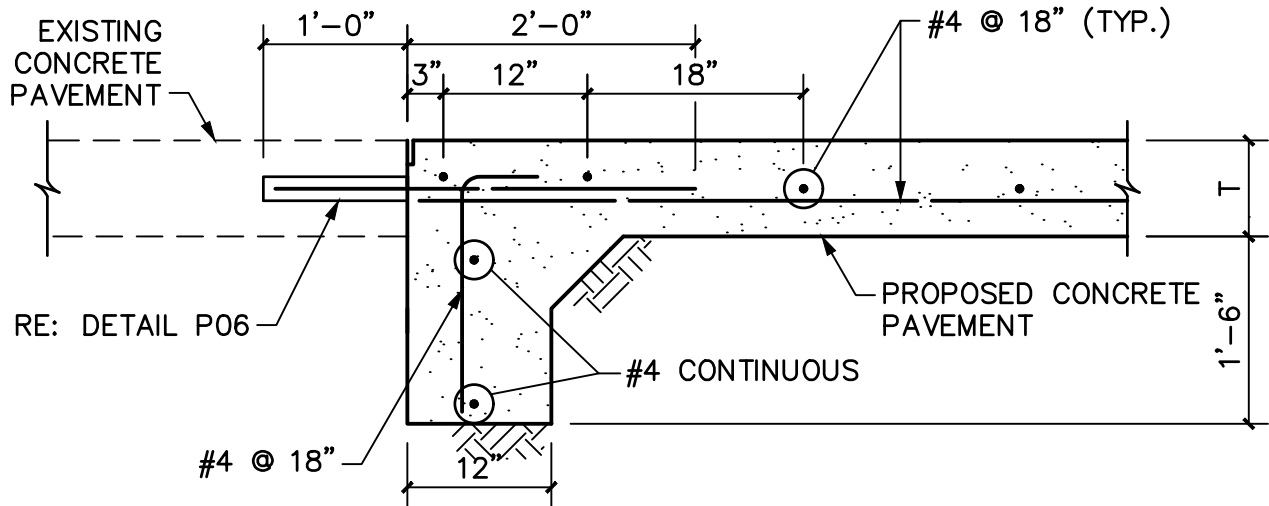

**STREET HEADER AT EXISTING PAVEMENT**

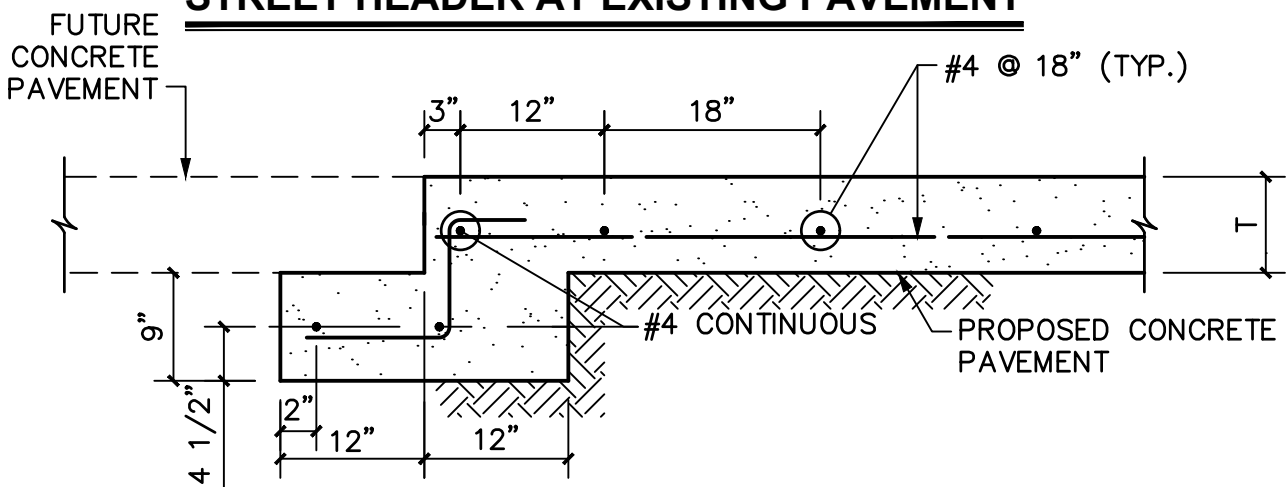

**STREET HEADER FOR FUTURE CONCRETE PAVEMENT**

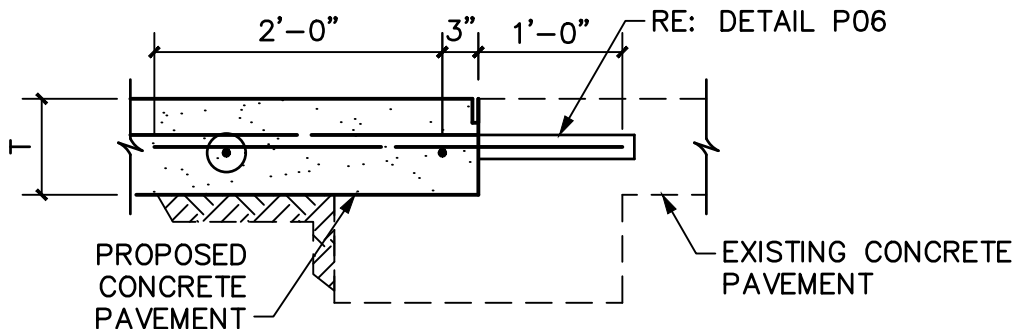

**CONCRETE PAVEMENT AT STREET HEADER**

**NOTES:**

1. REFER TO TXDOT ITEM 360 FOR CONCRETE PAVEMENT.
2. REFERENCE TYPICAL SECTIONS FOR PROPOSED CONCRETE PAVEMENT THICKNESS AND SUBGRADE TREATMENT.



STANDARD CONSTRUCTION DETAIL

CONCRETE STREET HEADERS

SCALE: 3/4"=1'-0"

REVISED:  
JANUARY 2022

P13

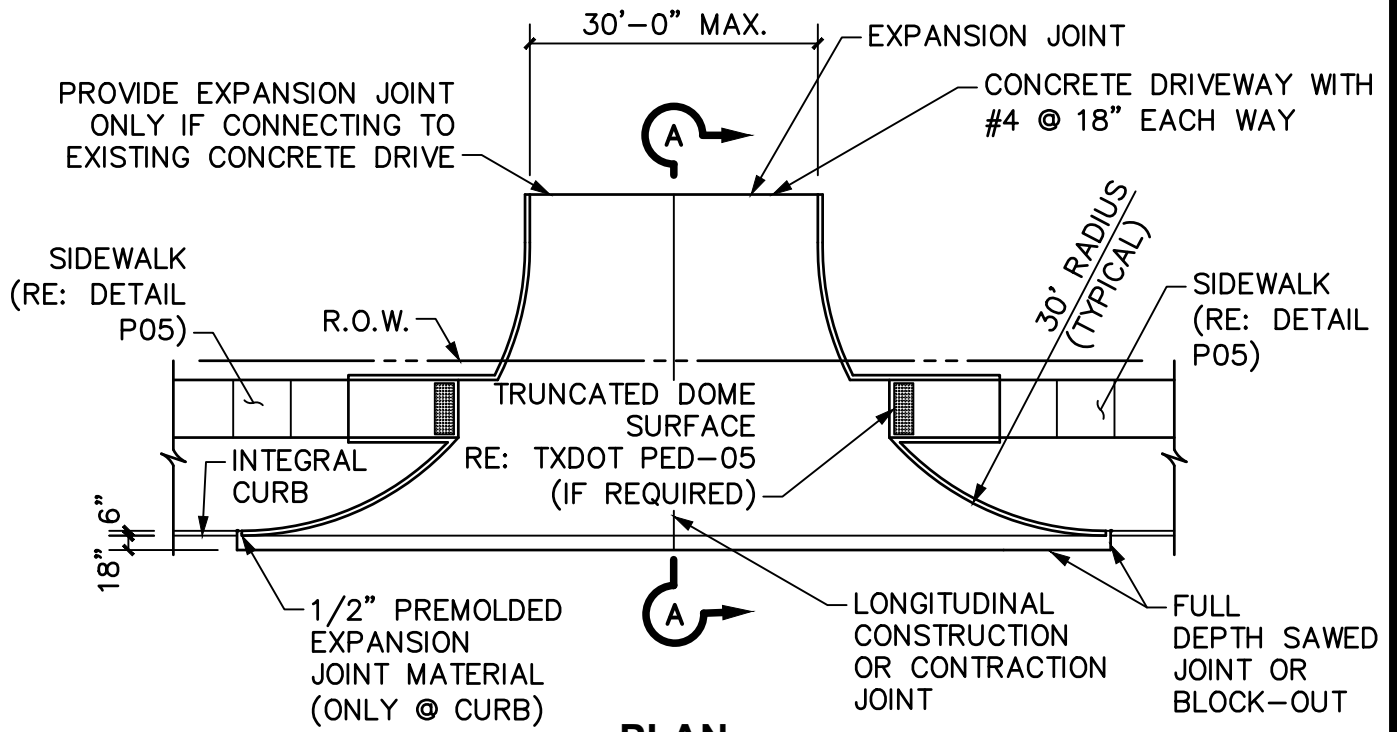

**PLAN**

SCALE: 1"=20'

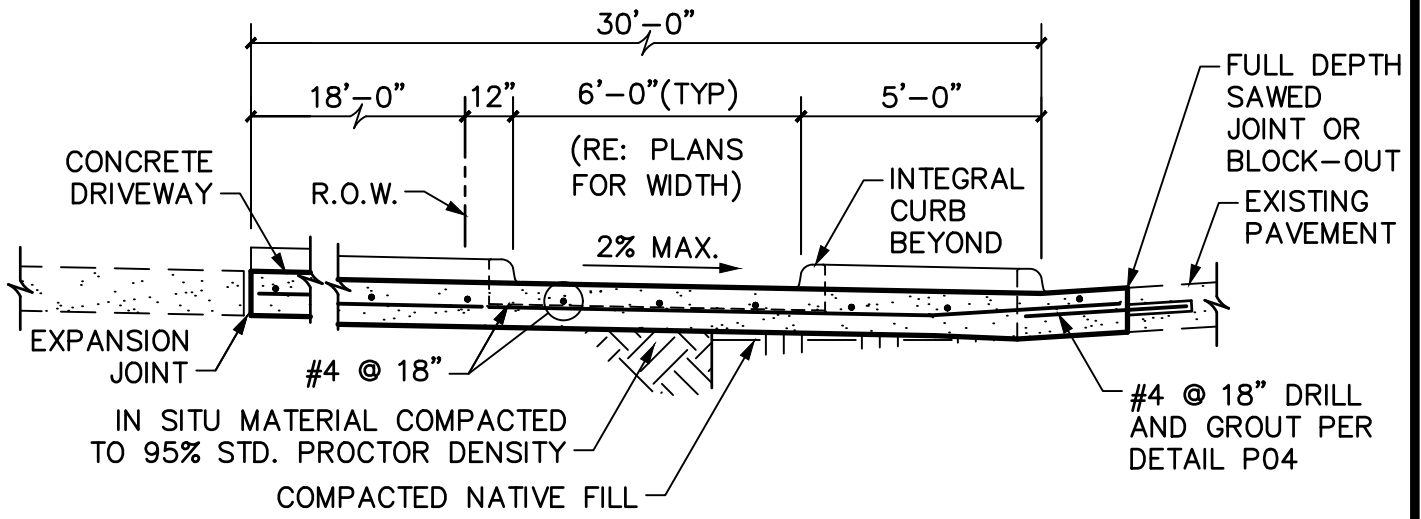

**SECTION A-A**

SCALE: 1/4"=1'-0"

**NOTES:**

1. ALL CONCRETE SHALL BE IN ACCORDANCE WITH TXDOT ITEM 360.
2. EXISTING CURB AND GUTTER SHALL BE VERTICALLY SAWCUT. HORIZONTAL SAWCUTTING OF CURB NOT ALLOWED.
3. SIDEWALK SECTION THROUGH DRIVEWAY SHALL BE POURED SAME THICKNESS AS DRIVEWAY APPROACH (EXISTING SIDEWALK, IF ANY, SHALL BE REMOVED).
4. DRIVEWAY THICKNESS TO MATCH STREET PAVEMENT THICKNESS (6" MINIMUM).



**STANDARD CONSTRUCTION DETAIL  
COMMERCIAL DRIVEWAY APPROACH**

SCALE: AS MARKED

REVISED:  
JANUARY 2022

P14

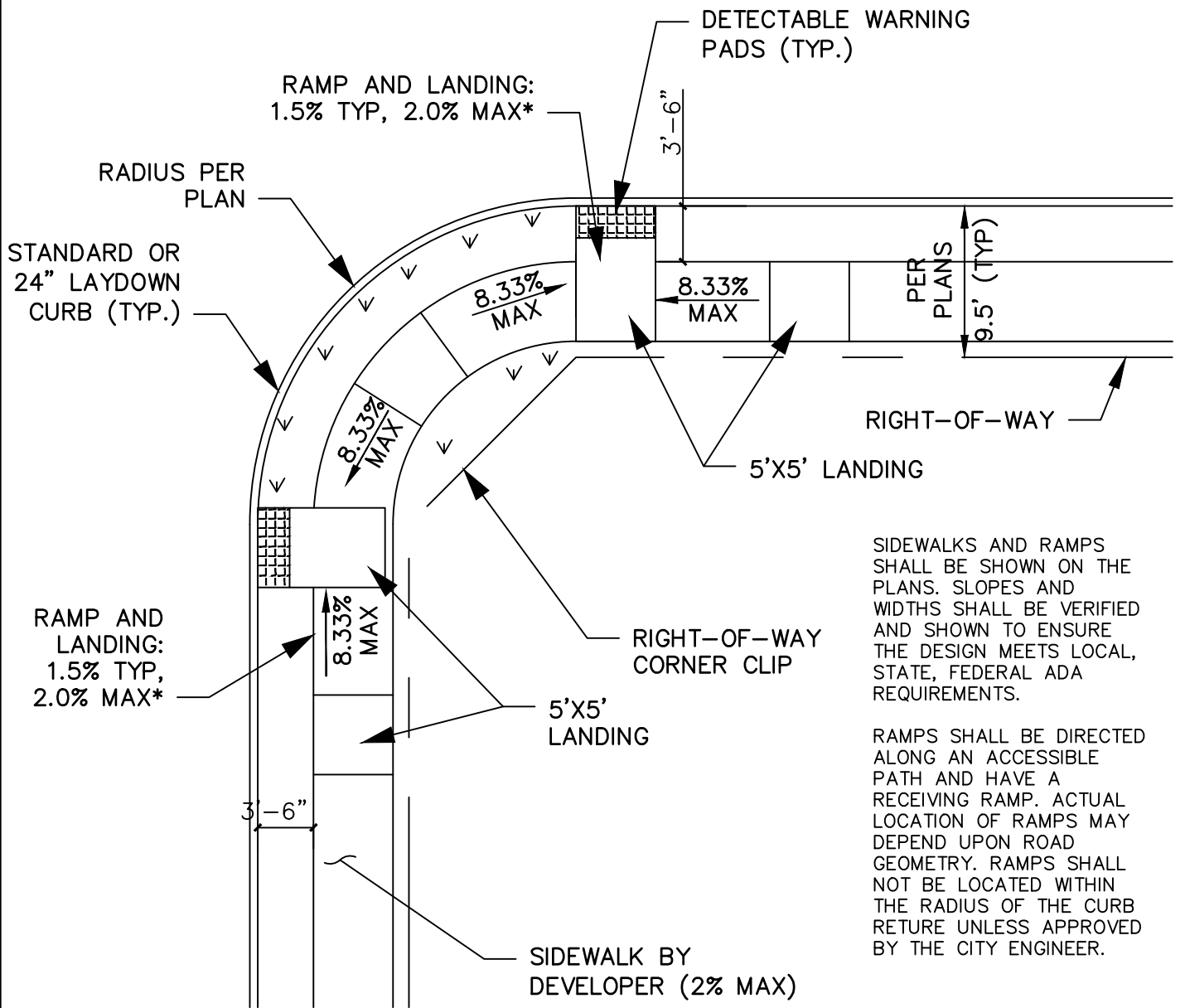

SIDEWALKS AND RAMPS SHALL BE SHOWN ON THE PLANS. SLOPES AND WIDTHS SHALL BE VERIFIED AND SHOWN TO ENSURE THE DESIGN MEETS LOCAL, STATE, FEDERAL ADA REQUIREMENTS.

RAMPS SHALL BE DIRECTED ALONG AN ACCESSIBLE PATH AND HAVE A RECEIVING RAMP. ACTUAL LOCATION OF RAMPS MAY DEPEND UPON ROAD GEOMETRY. RAMPS SHALL NOT BE LOCATED WITHIN THE RADIUS OF THE CURB RETURN UNLESS APPROVED BY THE CITY ENGINEER.

**NOTES:**

1. REFER TO TXDOT DETAIL PED-18 FOR ADDITIONAL DETAILS ON CURB RAMPS.
  2. RAMPS SHALL BE 4" 3000 PSI CONCRETE NO. 3 BARS 24" EACH WAY.
- \*LANDING MAY BE A PART OF THE RAMP DEPENDING ON DISTANCE BETWEEN THE CURB AND SIDEWALK. IF LANDING IS A PART OF THE RAMP, RAMP SLOPE MAY NOT EXCEED 2%. IN ALL OTHER SCENARIOS, RAMP SLOPE MAY NOT EXCEED 8.33%



**STANDARD CONSTRUCTION DETAIL**

**TYPICAL CURB RAMP**

SCALE: N.T.S.

REVISED:  
JANUARY 2022

P15

SEE DETAIL S03  
FOR PLACEMENT OF  
GRADE RINGS, FRAME,  
AND MANHOLE INSERT

NOTE:  
CONCRETE PAD SHALL  
BE PROVIDED IF  
MANHOLE IS NOT  
LOCATED IN PAVEMENT  
(SQUARE PAD SHALL  
EXTEND 6" ON ALL  
SIDE OF MANHOLE).

1. MAXIMUM HEIGHT ABOVE CONE SHALL BE 20". NO MORE THAN 4 GRADE RINGS.
2. MANHOLES SHALL BE CONCENTRIC UNLESS OTHERWISE APPROVED BY THE CITY.
3. 4'X4' PAVEMENT INSERTS OF 6" 3000 PSI CONCRETE SHALL BE PROVIDED FOR MANHOLE LIDS.
4. MANHOLES SHALL BE PER TXDOT ITEM 465.
5. MANHOLES SHALL BE LINED WITH SEWPERCOAT PER MANUFACTURER'S RECOMMENDATION

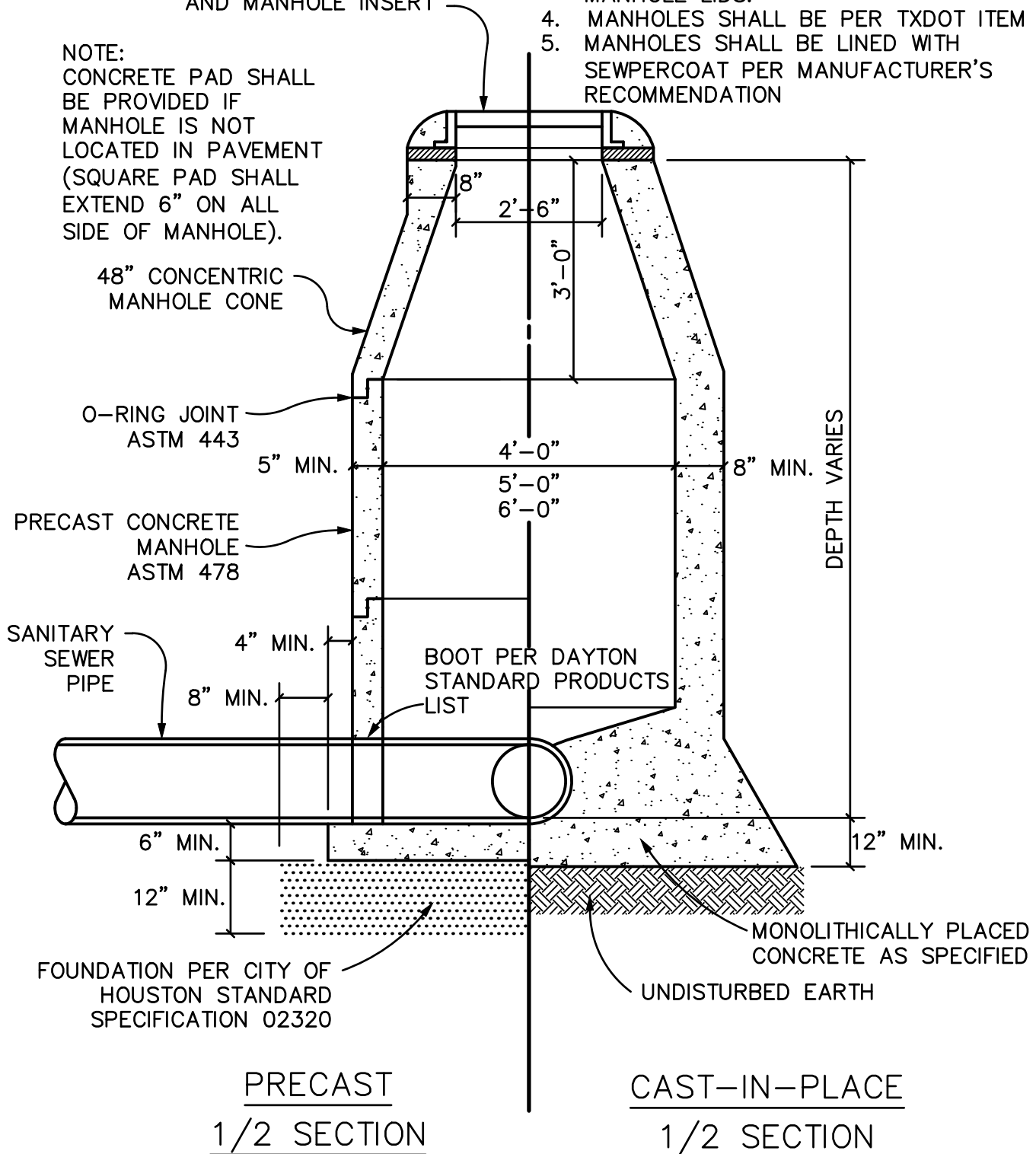

**STANDARD CONSTRUCTION DETAIL**  
**PRECAST AND CAST-IN-PLACE MANHOLE**

SCALE: 3/4"=1'-0"

REVISED:  
JANUARY 2022

S01

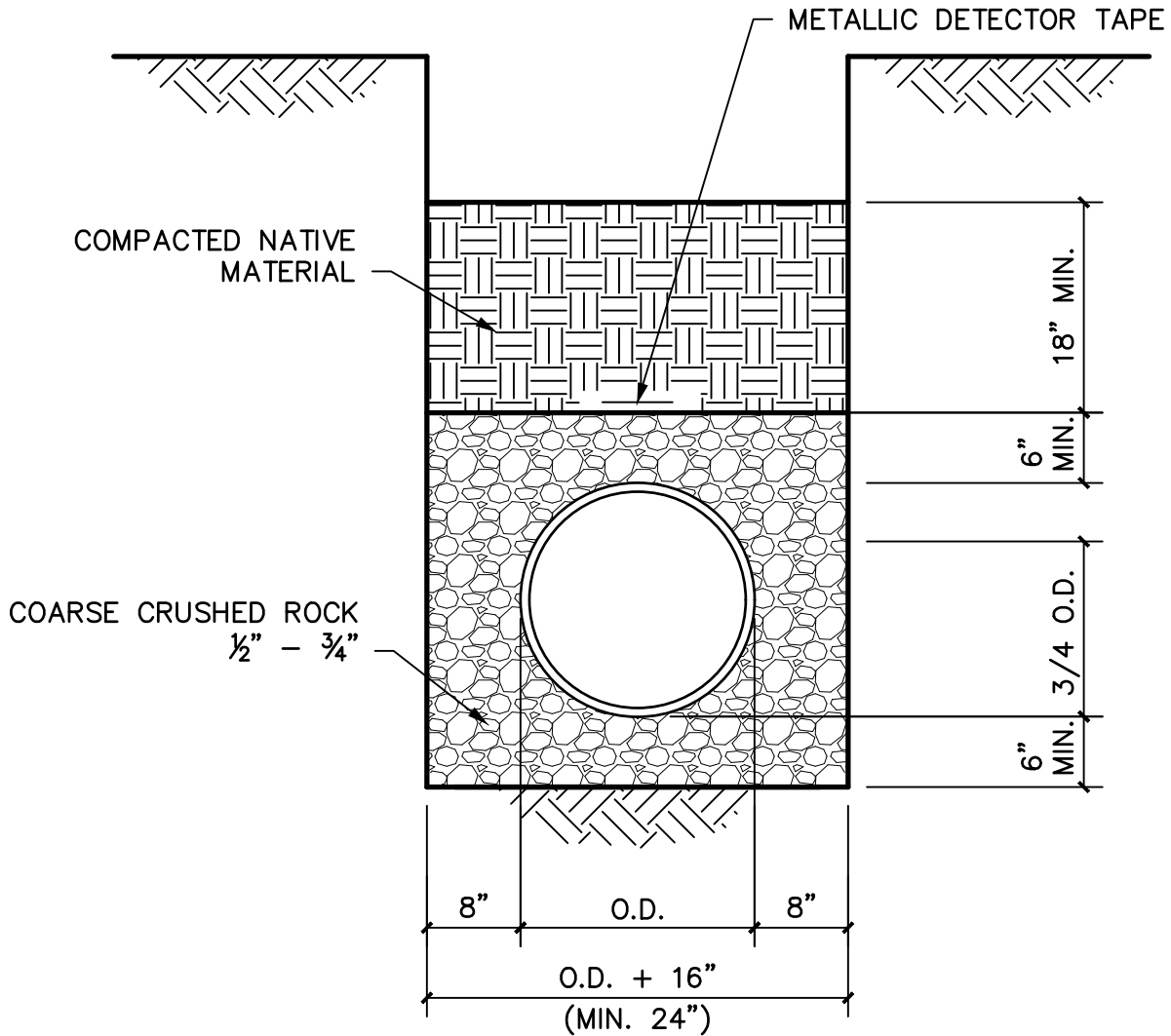

**CRUSHED STONE**

**NOTES:**

1. UTILIZE CRUSHED STONE EMBEDMENT FOR PVC (SDR-26) WASTEWATER LINE INSTALLATIONS.
2. INSTALLATION SHALL BE IN ACCORDANCE WITH CITY OF HOUSTON STANDARD SPECIFICATION 02320.
3. BEDDING DEPTH MEASURED FROM OUTSIDE THE PIPE BELL.



**STANDARD CONSTRUCTION DETAIL**  
**EMBEDMENT (WASTEWATER)**

SCALE: 3/4"=1'-0"

REVISED:  
JANUARY 2022

S02

6-1/2" DIA. STAINLESS  
STEEL ANCHOR BOLTS IN  
5/8" DIA. HOLES

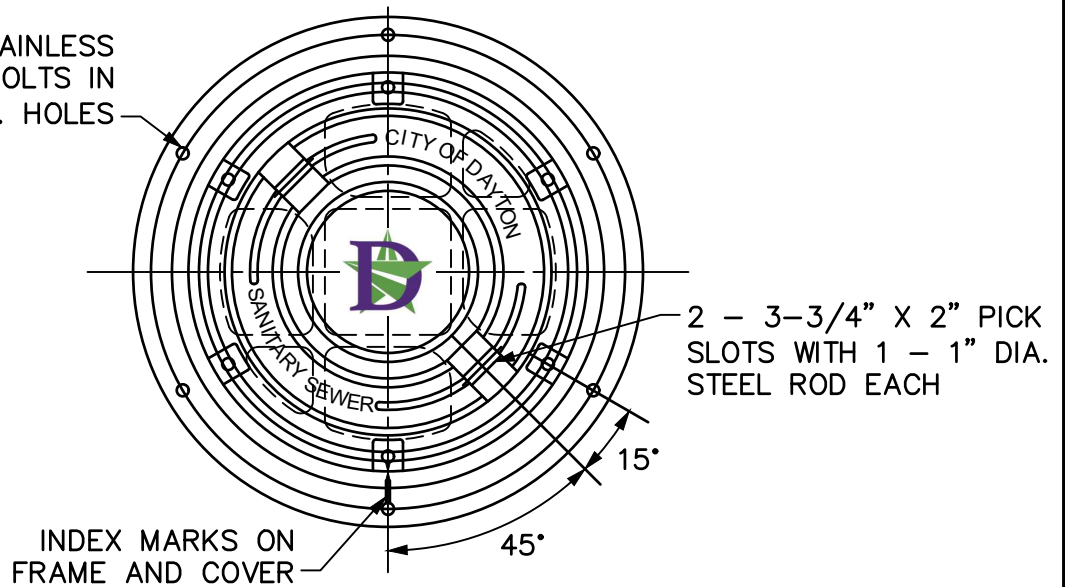

2 - 3-3/4" X 2" PICK  
SLOTS WITH 1 - 1" DIA.  
STEEL ROD EACH

**ASSEMBLY PLAN VIEW**

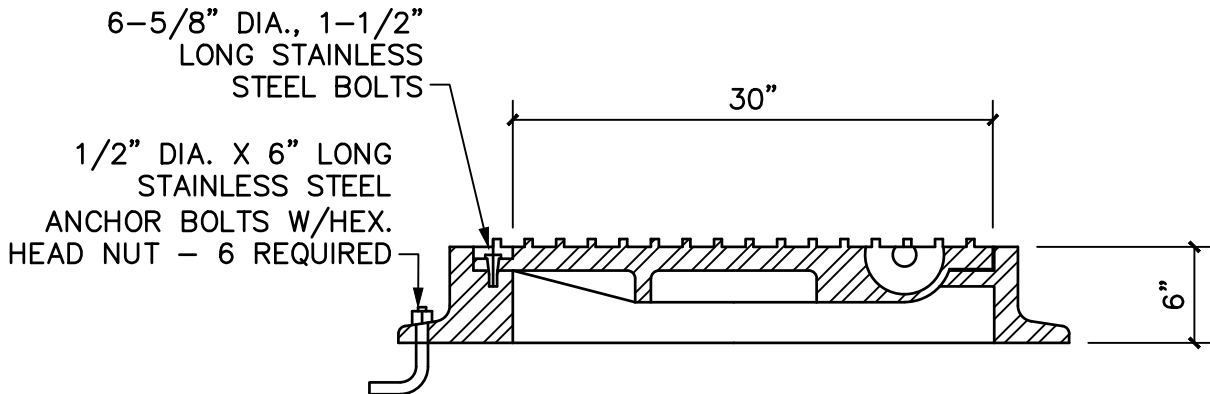

**ASSEMBLY CROSS SECTION**

**NOTES:**

1. MANHOLE LID AND FRAME SHALL BE CAST IRON.
2. THE HORIZONTAL BEARING SURFACES ARE TO BE MACHINE FINISHED.
3. FOR A SEAL BETWEEN THE RING FRAME AND COVER A 1/4" DIA. NEOPRENE "O-RING" GASKET SHALL BE INSTALLED BY THE MANUFACTURER. THE LOCATION SHALL BE AS PER THE MANUFACTURER'S STANDARDS BUT SHALL BE SUBJECT TO THE APPROVAL OF THE CITY.
4. THE SOLID LID WILL BE PROVIDED WITH MANUFACTURER'S STANDARD LETTERING SHOWING "SANITARY SEWER".
5. NOT ALLOWED IN TRAFFIC AREA.



**STANDARD CONSTRUCTION DETAIL**  
**PRESSURE MANHOLE LID AND FRAME**

SCALE: 1"=1'-0"

REVISED:  
JANUARY 2022

S03



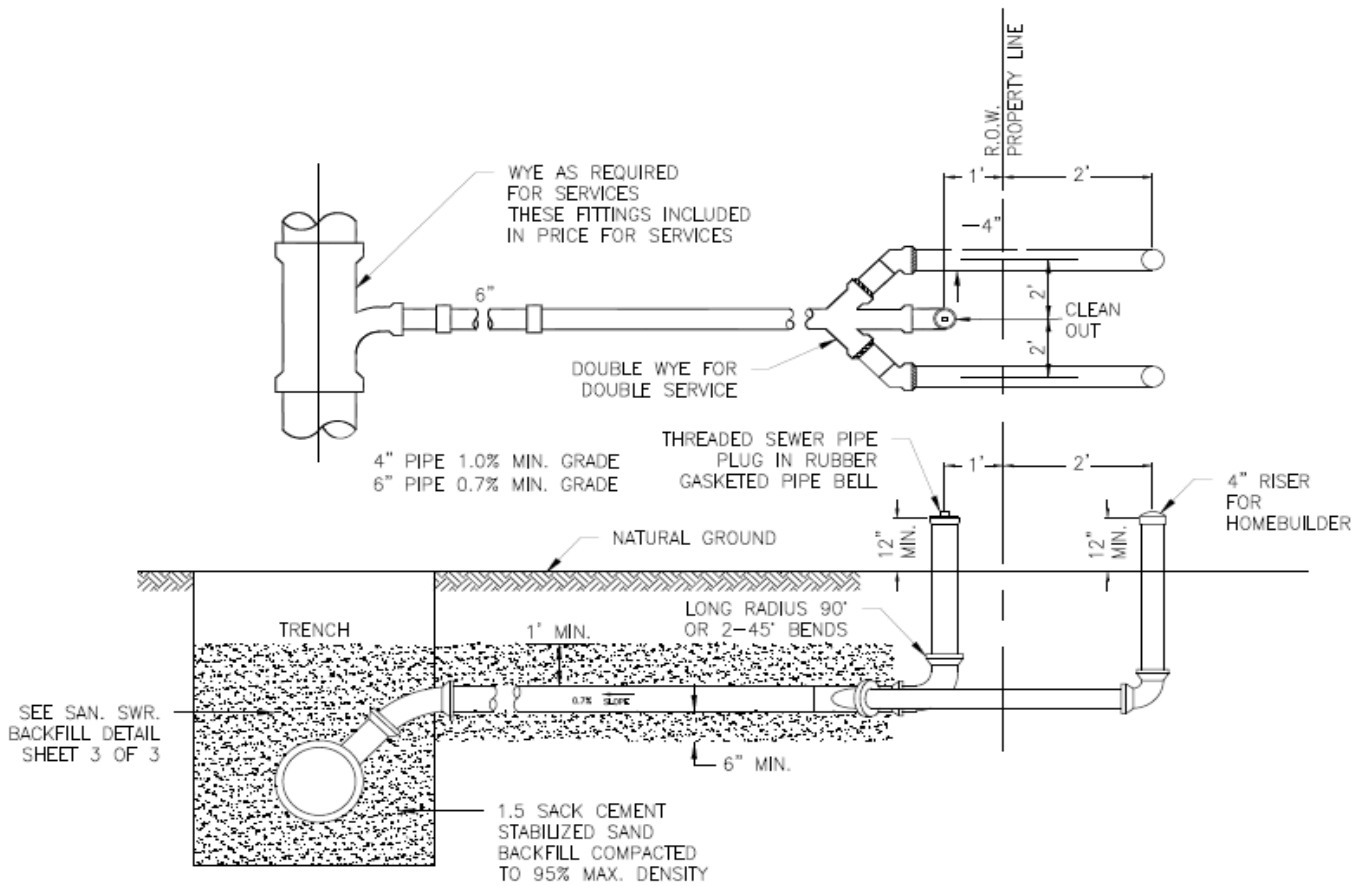

**DOUBLE SEWER SERVICE**

**NOTES:**

1. SANITARY SEWER LATERALS SHALL EXTEND TO A POINT 10' BEYOND RIGHT OF WAY LINE AND SHALL BE A MAXIMUM OF 5' DEEP.
2. SEWER SERVICES SHALL NOT BE BACKFILLED UNTIL VISUALLY INSPECTED BY CITY INSPECTOR.
3. SANITARY SEWER SERVICES SHALL NOT BE CONNECTED TO MANHOLE.
4. RESIDENTIAL SEWER LATERAL SHALL BE MINIMUM 4" PVC SDR 35 AT A 2% MINIMUM GRADE.
5. DURING INITIAL LATERAL INSTALLATION, A 4" CLEANOUT SHALL BE BROUGHT 3-4' ABOVE GRADE AT THE R-O-W LINE.
6. PRIOR TO FINAL GRADING, LATERAL LOCATION SHALL BE MARKED ON CURB AND CLEANOUT TO BE CUT 1' BELOW GRADE.

(MARK ACTUAL STATION AND FLOW LINE ELEVATION OF EACH SERVICE CONNECTION AT PLUG ON AS-BUILT DRAWINGS.)

STANDARD CONSTRUCTION DETAIL DOUBLE SEWER SERVICE		
DATE: 02/2023	DR. BY: GTG	SCALE: NTS
<b>LEAD</b>		
LEAVINS ENGINEERING & DESIGN, LLC TEXAS ENGINEERING FIRM NO. F-22257 3250 EASTER FWY, BEAUMONT, TEXAS 77705 409-892-0421   LEADLLC.COM		

Standard Construction Detail - Residential Sewer Service - LEAD, Inc.

 <p>DAYTON TEXAS</p>	<p><b>STANDARD CONSTRUCTION DETAIL RESIDENTIAL LATERAL W/ CLEANOUT AT PROPERTY LINE</b></p>	<p><b>SCALE: 3/4"=1'-0"</b></p>
		<p>REVISED: FEBRUARY 2023</p>
		<p>S04</p>

INCLUDING THE CITY OF DAYTON STANDARD CONSTRUCTION DETAIL IN PLANS DOES NOT RELIEVE THE SEALING ENGINEER OF THE RESPONSIBILITY FOR THE SPECIFIC DESIGN. THESE DETAILS SHOULD BE CONSIDERED MINIMUM STANDARDS WHICH THE SEALING ENGINEER MAY MODIFY TO MEET SITE SPECIFIC DESIGN REQUIREMENTS.

NOTE:  
 CONCRETE PAD SHALL BE PROVIDED IF MANHOLE IS NOT LOCATED IN PAVEMENT (SQUARE PAD SHALL EXTEND 6" ON ALL SIDE OF MANHOLE).

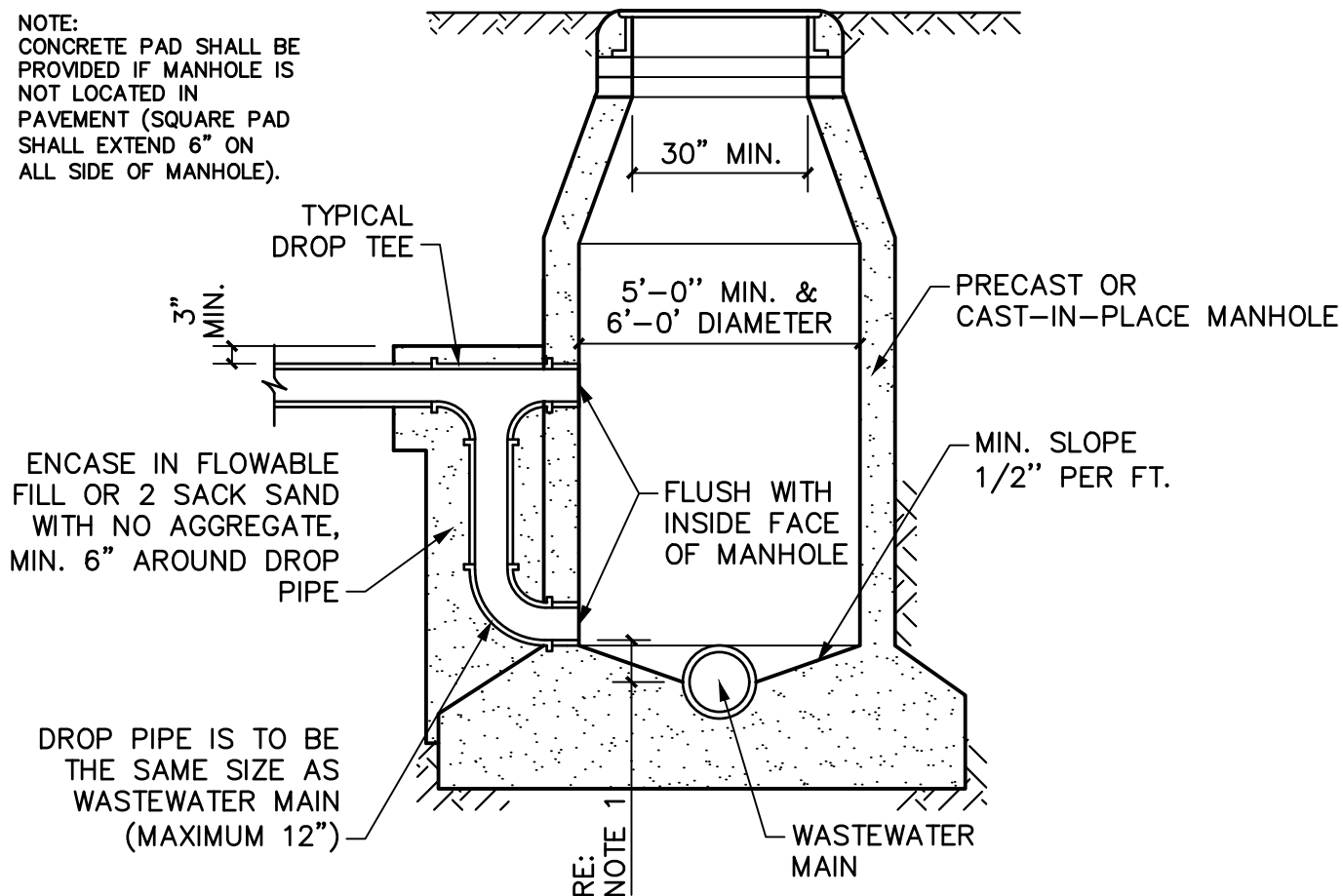

**NOTES:**

1. FLOWLINE OF DROP SHALL BE LOCATED BETWEEN THE CENTERLINE AND TOP OF WASTEWATER MAIN.
2. THERE SHALL BE A MINIMUM OF TWO-TENTHS OF A FOOT (0.1') DROP BETWEEN INVERTS OF PIPES IN AND OUT OF MANHOLES.
3. WHERE UNEQUAL PIPES ENTER A MANHOLE, THE CROWN OF THE PIPES SHALL BE SET AT THE SAME ELEVATION.
4. MATERIALS AND INSTALLATION SHALL BE IN ACCORDANCE WITH TXDOT ITEM 465.
5. RAVEN LINING OR APPROVED EQUAL SHALL BE PLACED ON ALL DROP MANHOLES.

	<p><b>STANDARD CONSTRUCTION DETAIL</b></p> <p><b>MANHOLE DROP CONNECTION</b></p>	<p>SCALE: 3/8"=1'-0"</p> <p>REVISED:          JANUARY 2022</p> <p>S05</p>
---	--	---

INCLUDING THE CITY OF DAYTON STANDARD CONSTRUCTION DETAIL IN PLANS DOES NOT RELIEVE THE SEALING ENGINEER OF THE RESPONSIBILITY FOR THE SPECIFIC DESIGN. THESE DETAILS SHOULD BE CONSIDERED MINIMUM STANDARDS WHICH THE SEALING ENGINEER MAY MODIFY TO MEET SITE SPECIFIC DESIGN REQUIREMENTS.

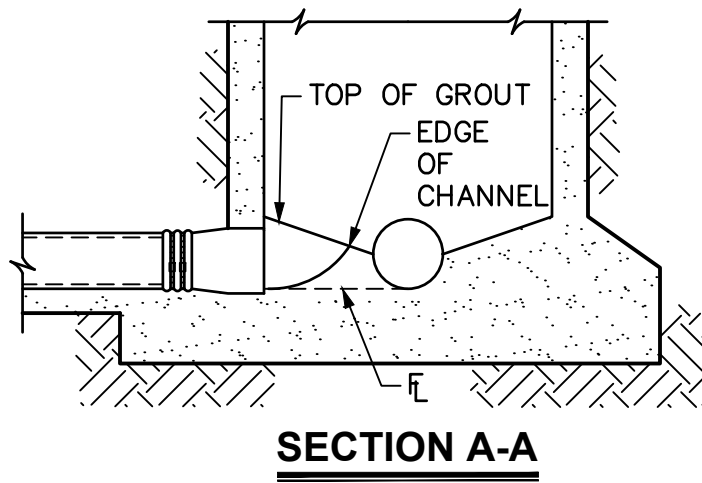
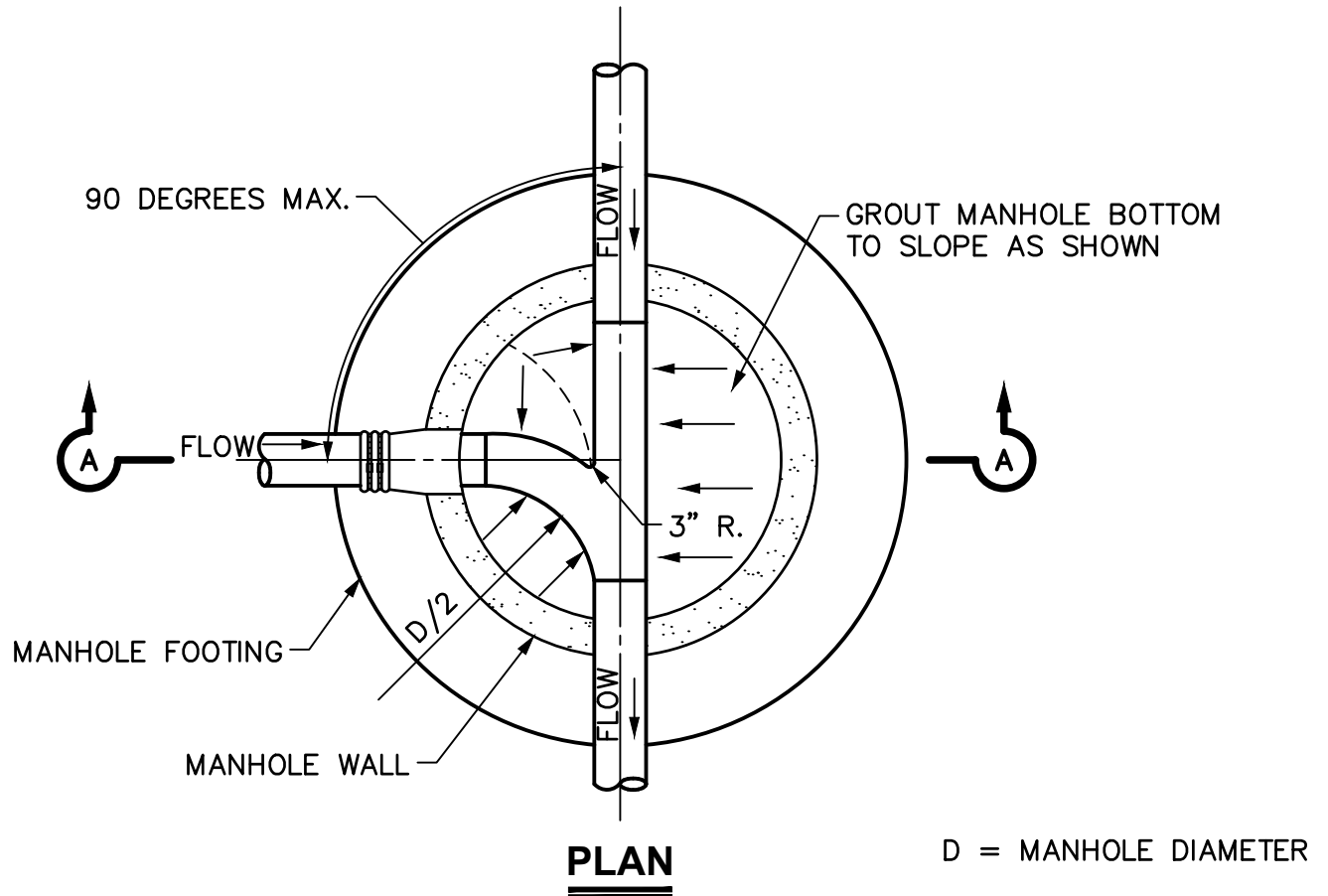

**NOTE:**

1. REFER TO MANHOLE STANDARD DRAWINGS FOR ADDITIONAL DETAIL OF MANHOLE (RE: DETAILS S01).



**STANDARD CONSTRUCTION DETAIL  
WASTEWATER MANHOLE  
LINE INTERSECTION**

SCALE: 3/8"=1'-0"

REVISED:  
JANUARY 2022

S06

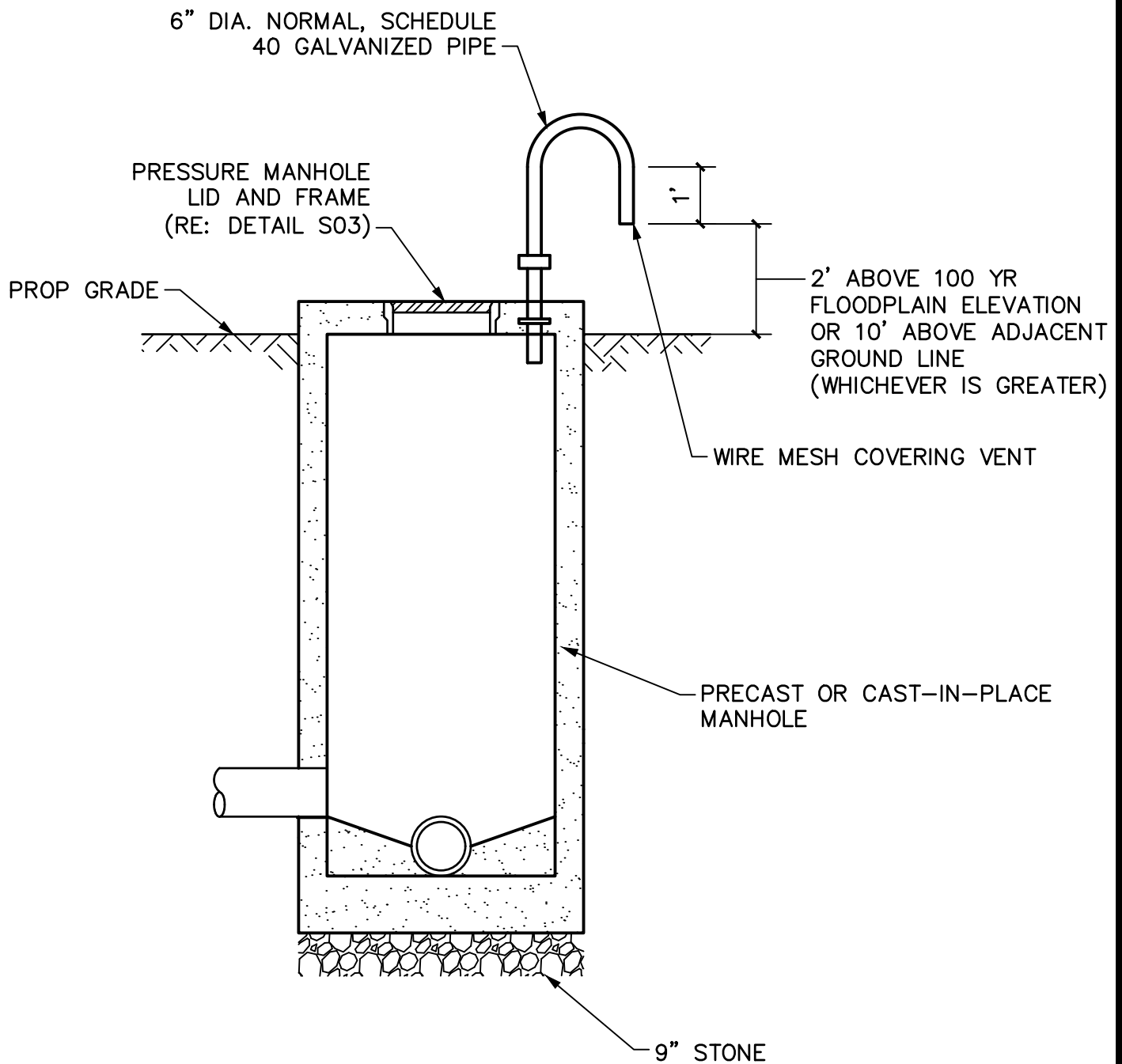

**NOTE:**

1. REFER TO STANDARD DETAIL S01 FOR MANHOLE DETAILS.
2. MANHOLES SHALL BE PER TXDOT ITEM 465.
3. S07B MAY BE USED AS DIRECTED BY THE CITY.



**STANDARD CONSTRUCTION DETAIL**

**VENTED TYPE S MANHOLE**

SCALE: 3/8"=1'-0"

REVISED:  
JANUARY 2022

S07A

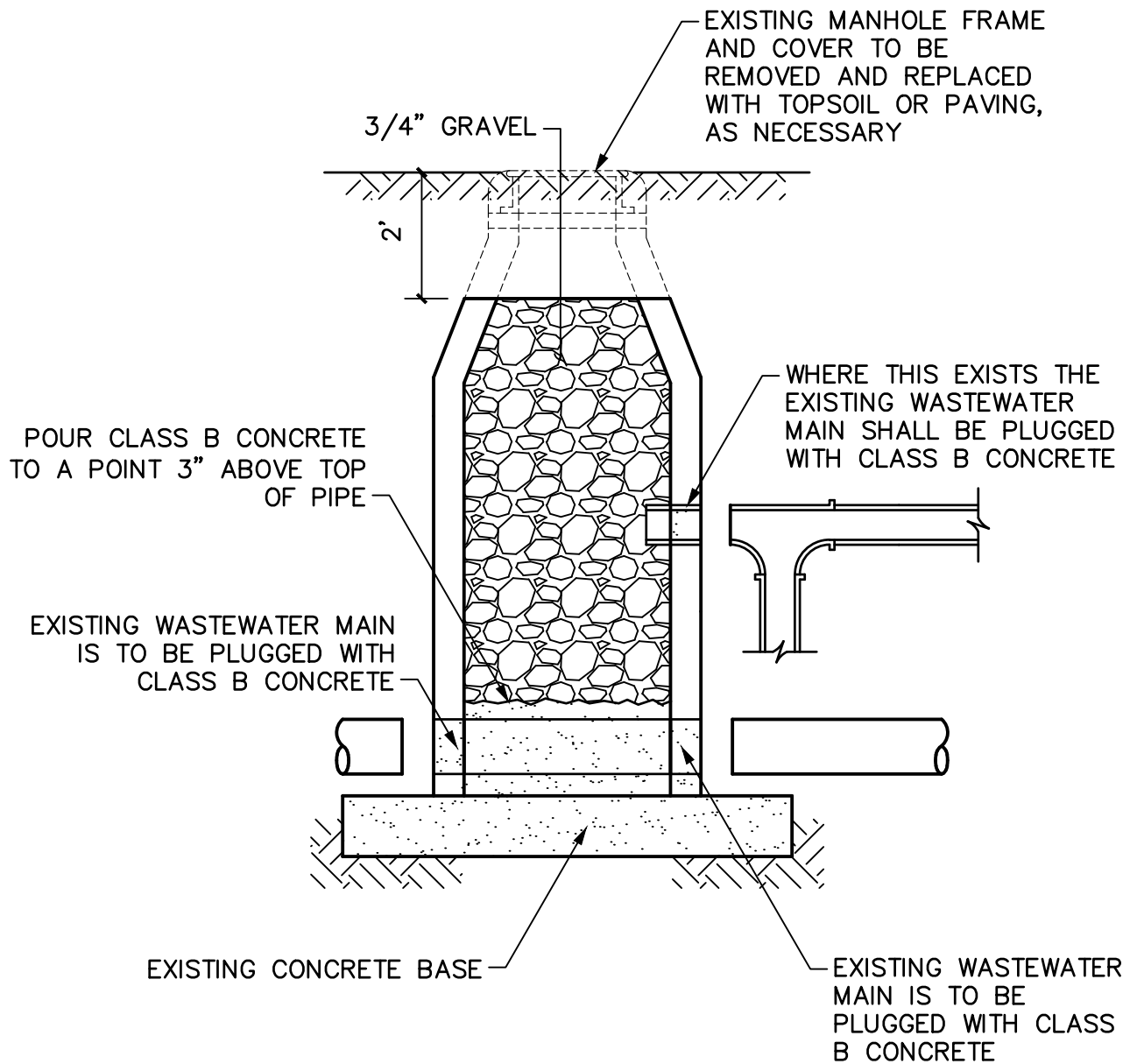

**NOTES:**

1. CITY MAY MODIFY DEPENDING UPON FIELD CONDITIONS. EXISTING LINES SHALL BE CUT AND PLUGGED AT CITY'S DIRECTION.
2. ALL MAIN LINES COMING INTO THE MANHOLE SHALL BE CUT AND PLUGGED.
3. REFER TO TXDOT ITEM 421 FOR CLASS B CONCRETE REQUIREMENTS.



**STANDARD CONSTRUCTION DETAIL**

**MANHOLE ABANDONMENT**

SCALE: N.T.S.

REVISED:  
JANUARY 2022

S08

H'	4	5	6	7	8	9	10	11	12	13	14	15	16	17	18	19	20	H'
Y'	10	12	14	17	19	22	24	27	29	31	34	36	39	41	43	46	48	Y'

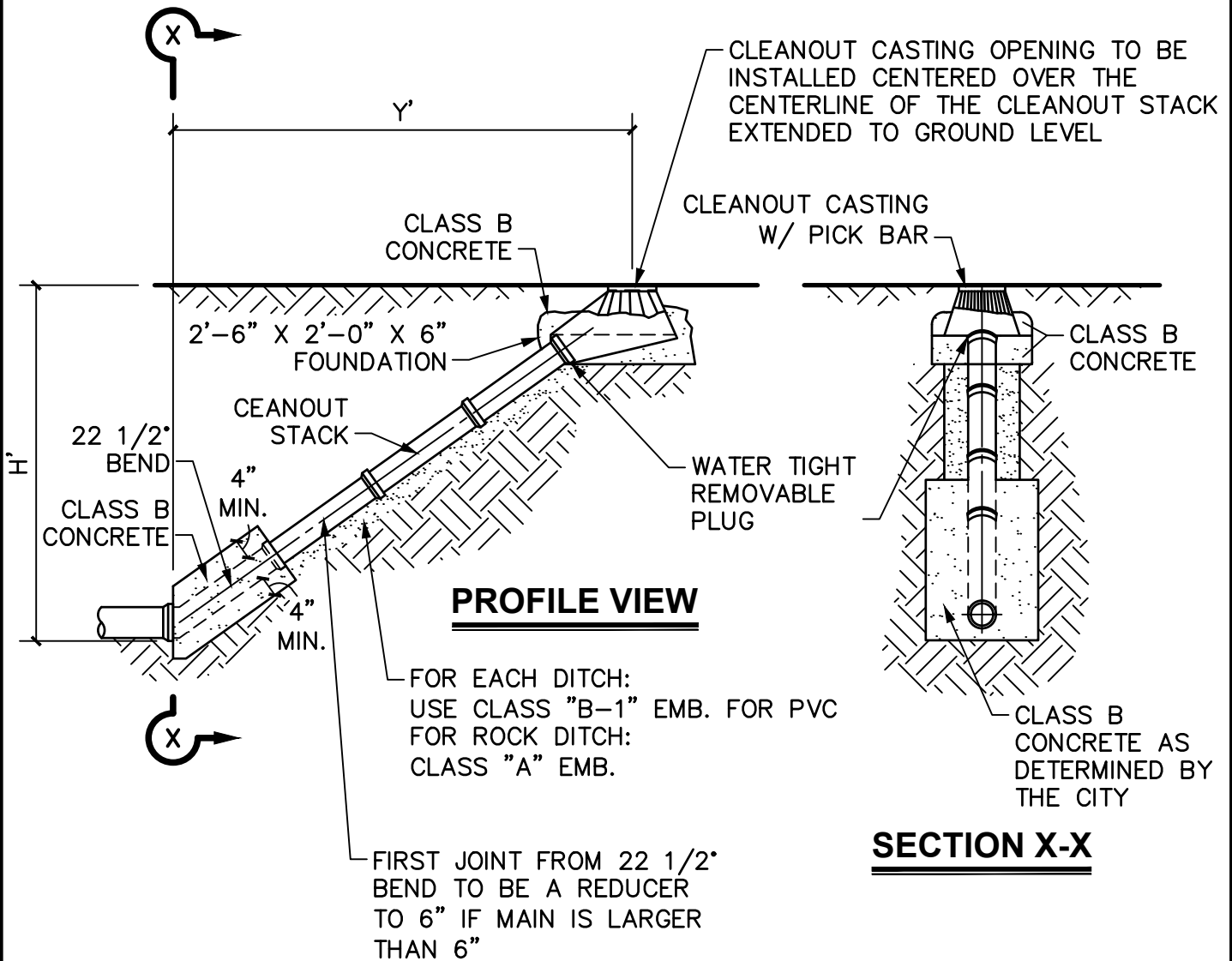

**NOTES:**

1. IF CLEANOUT IS PLACED IN ADVANCE OF PAVEMENT PLACE SAND AROUND CLEANOUT CASTING IN LIEU OF CLASS B CONCRETE.
2. IF CLEANOUT IS OUTSIDE OF PAVEMENT, CENTER CASTING IN 24" X 24" CLASS A CONCRETE PAD 6" THICK WITH FOUR #3 BARS.
3. REFER TO TXDOT ITEM 421 FOR CLASS A AND CLASS B CONCRETE REQUIREMENTS.

	<b>STANDARD CONSTRUCTION DETAIL</b> <b>WASTEWATER MAIN</b> <b>CLEANOUT</b>	SCALE: 3/8"=1'-0" REVISED: JANUARY 2022
		S09

INCLUDING THE CITY OF DAYTON STANDARD CONSTRUCTION DETAIL IN PLANS DOES NOT RELIEVE THE SEALING ENGINEER OF THE RESPONSIBILITY FOR THE SPECIFIC DESIGN. THESE DETAILS SHOULD BE CONSIDERED MINIMUM STANDARDS WHICH THE SEALING ENGINEER MAY MODIFY TO MEET SITE SPECIFIC DESIGN REQUIREMENTS.

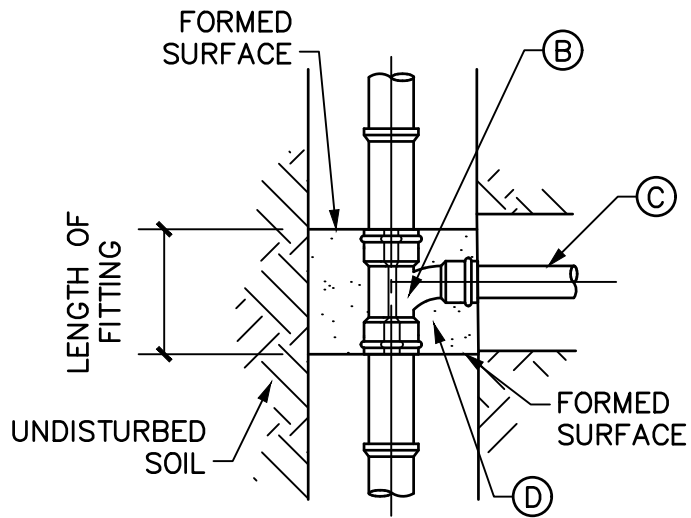

**PLAN VIEW**

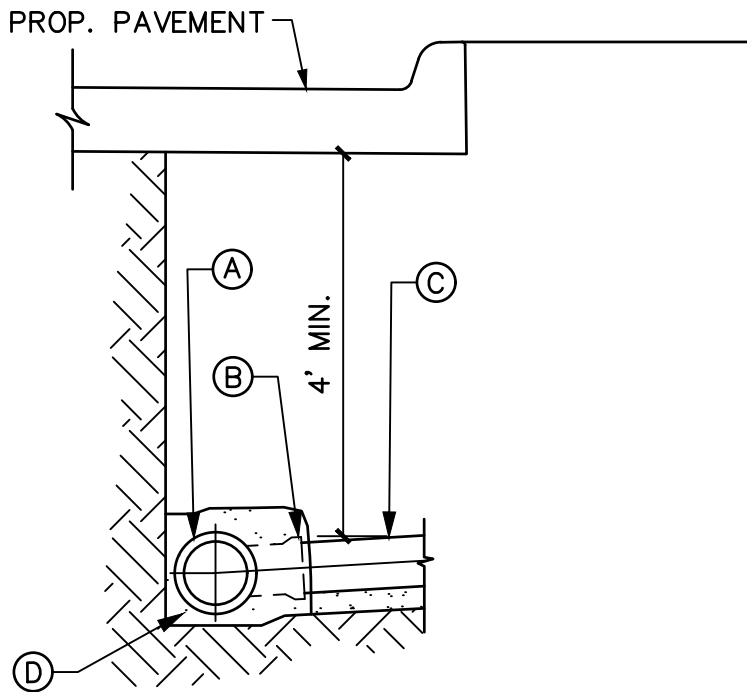

**SECTION VIEW**

**KEY:**

- (A) WASTEWATER MAIN
- (B) 4" WYE
- (C) 4" WASTEWATER LAT. (LENGTH VARIES)
- (D) CLASS B CONCRETE PER TXDOT ITEM 421



**STANDARD CONSTRUCTION DETAIL**

**WASTEWATER LATERAL**

SCALE: 1/2"=1'-0"

REVISED:  
JANUARY 2022

S10



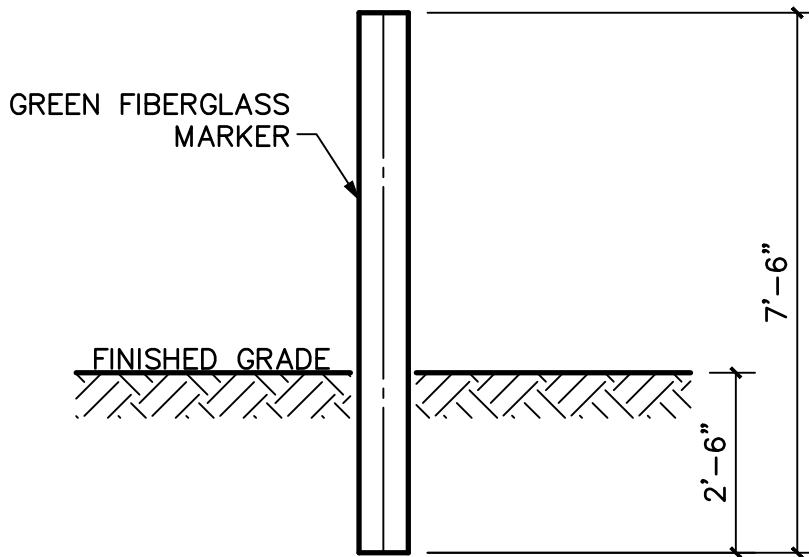

**ELEVATION**

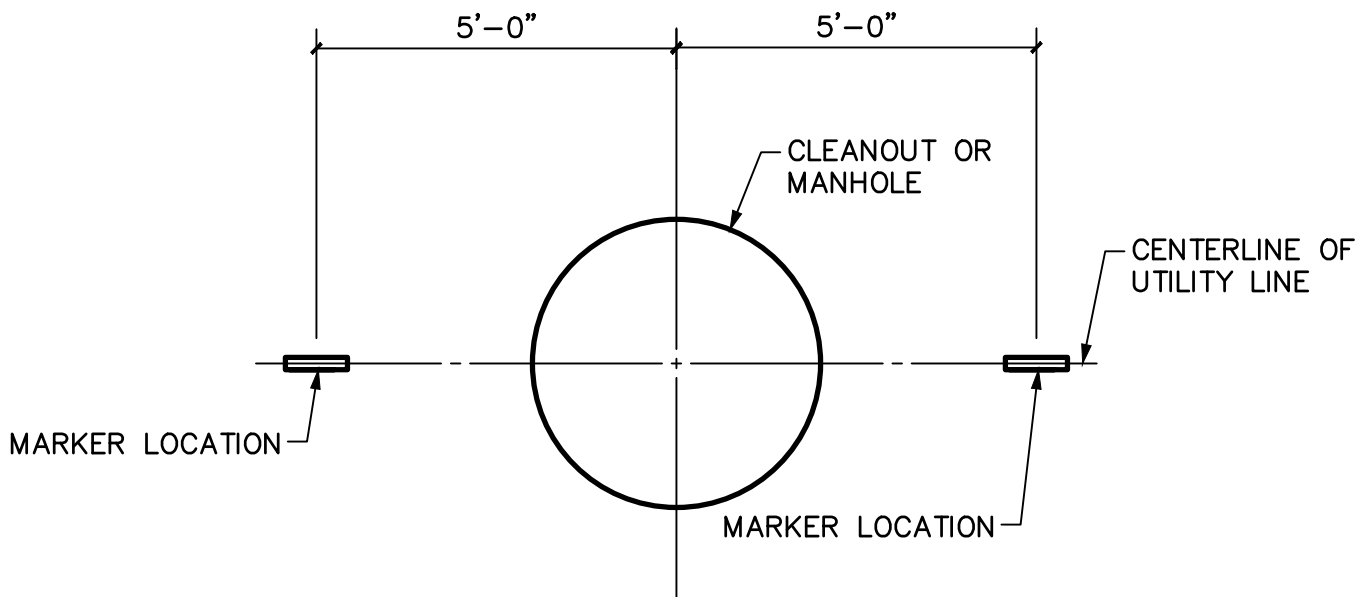

**FIELD INSTALLATION DETAIL**

**NOTES:**

1. ALL OFFSITE CITY MAINS WITH CLEANOUTS AND MANHOLES SHALL BE MARKED AS DETAILED ON THIS SHEET.
2. THE OFFSITE SANITARY SEWER MARKER SHALL HAVE THE FOLLOWING WRITING: "CITY SANITARY SEWER".



**STANDARD CONSTRUCTION DETAIL**

**OFFSITE WASTEWATER MARKER**

SCALE: 3/8"=1'

REVISED:  
JANUARY 2022

S11

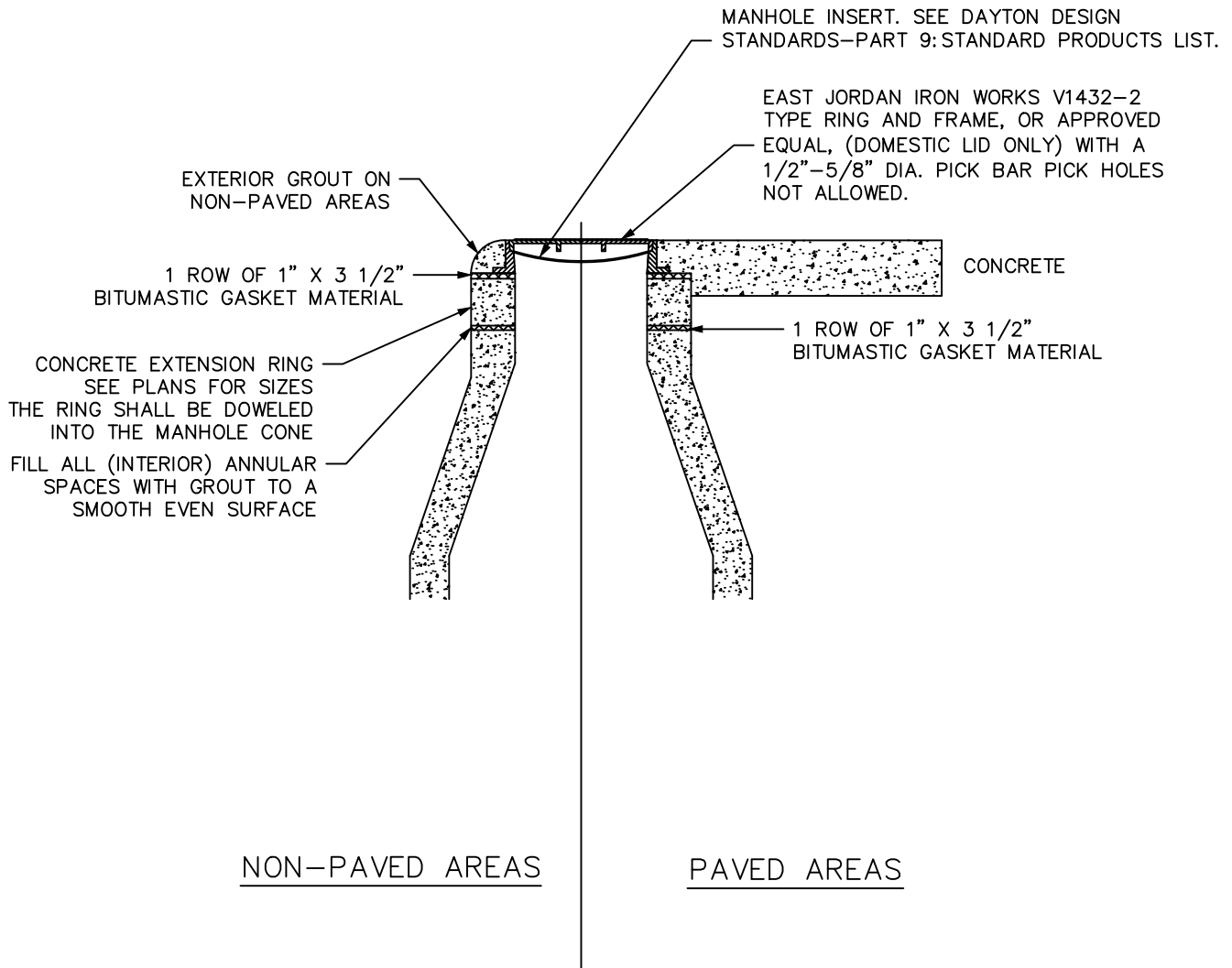

NOTES:

1. NO GAPS WILL BE ALLOWED IN BITUMASTIC GASKET.
2. ONLY DOMESTICALLY MADE MANHOLE FRAMES AND COVERS SHALL BE USED.
3. THERE SHALL BE A SMOOTH TRANSITION BETWEEN THE FRAME AND CONE OR GRADE RING, OR THE GRADE RING AND THE CONE.
4. MANHOLE INSERTS SHALL BE MADE OF HIGH-DENSITY POLYETHYLENE THAT MEETS ASTM D-1248, CLASS A, CATEGORY 5, TYPE 111 STANDARDS AND IS A UNIFORM THICKNESS OF 1/8" OR GREATER. AN ENVELOPE-STYLE GASKET, RIBBED ON ONE SIDE TO ENSURE A POSITIVE SEAL AND DESIGNED NOT TO SEPARATE FROM THE INSERT DURING INSTALLATION AND REMOVAL, SHALL BE FURNISHED. INSERTS SHOULD PROVIDE A GAS RELEASE HOLE (1/8") HAVING A WATER LEAKAGE RATE NOT TO EXCEED 1/2 GPH. TWO 1" WIDE NYLON LIFT STRAPS ATTACHED TO THE INSERT WITH TWO HIGH GRADE STAINLESS STEEL RIVETS WITH WASHERS ARE REQUIRED.



**STANDARD CONSTRUCTION DETAIL**  
**EXTENSION RING INSTALLATION**  
**FRAME/COVER PLACEMENT**

SCALE: 3/4"=1'-0"

REVISED:  
 JANUARY 2022

S12

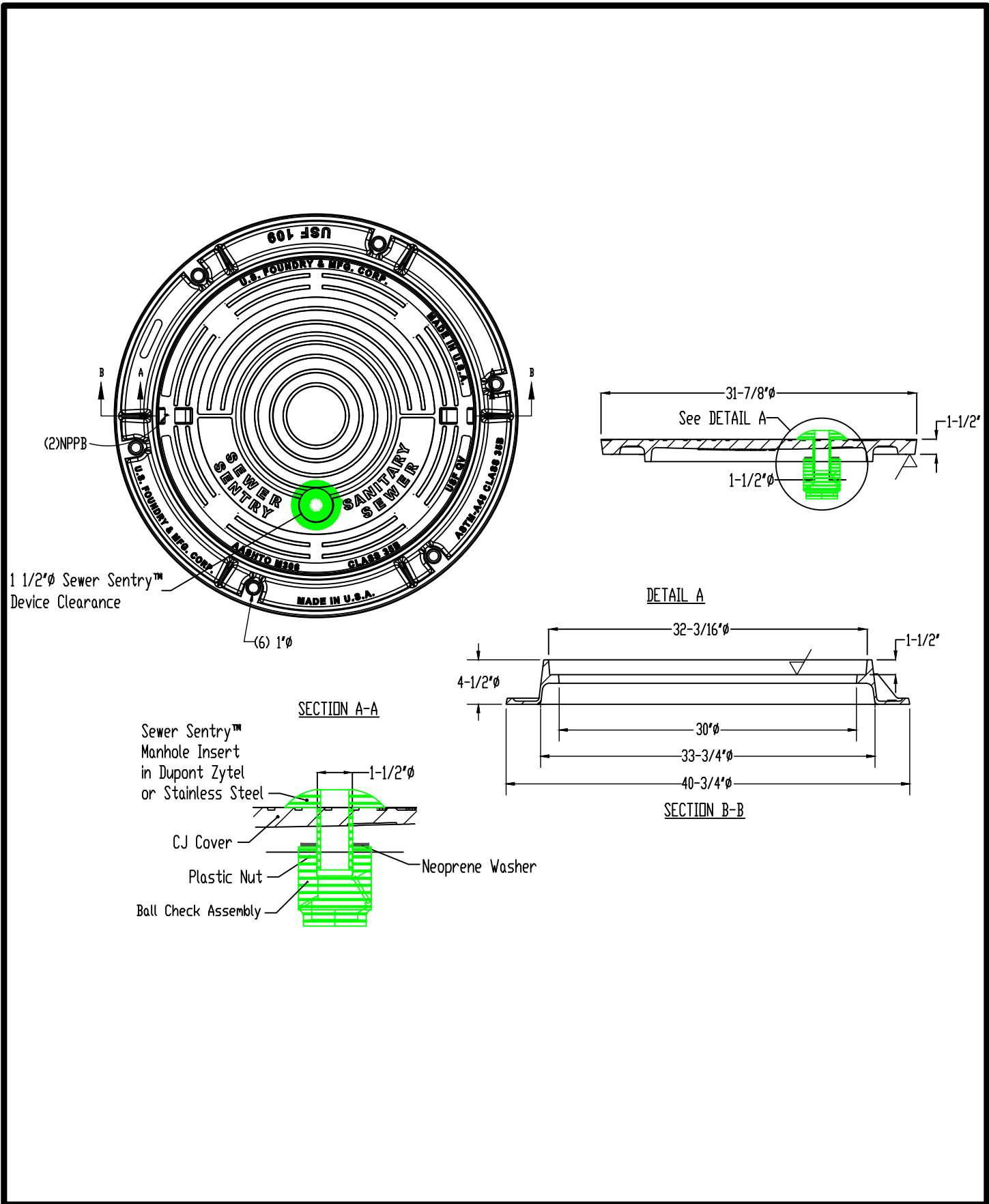

**STANDARD CONSTRUCTION DETAIL  
EXTENSION RING INSTALLATION  
FRAME/COVER PLACEMENT**

NOT TO SCALE  
REVISED:  
JANUARY 2022  
S13

INCLUDING THE CITY OF DAYTON STANDARD CONSTRUCTION DETAIL IN PLANS DOES NOT RELIEVE THE SEALING ENGINEER OF THE RESPONSIBILITY FOR THE SPECIFIC DESIGN. THESE DETAILS SHOULD BE CONSIDERED MINIMUM STANDARDS WHICH THE SEALING ENGINEER MAY MODIFY TO MEET SITE SPECIFIC DESIGN REQUIREMENTS.

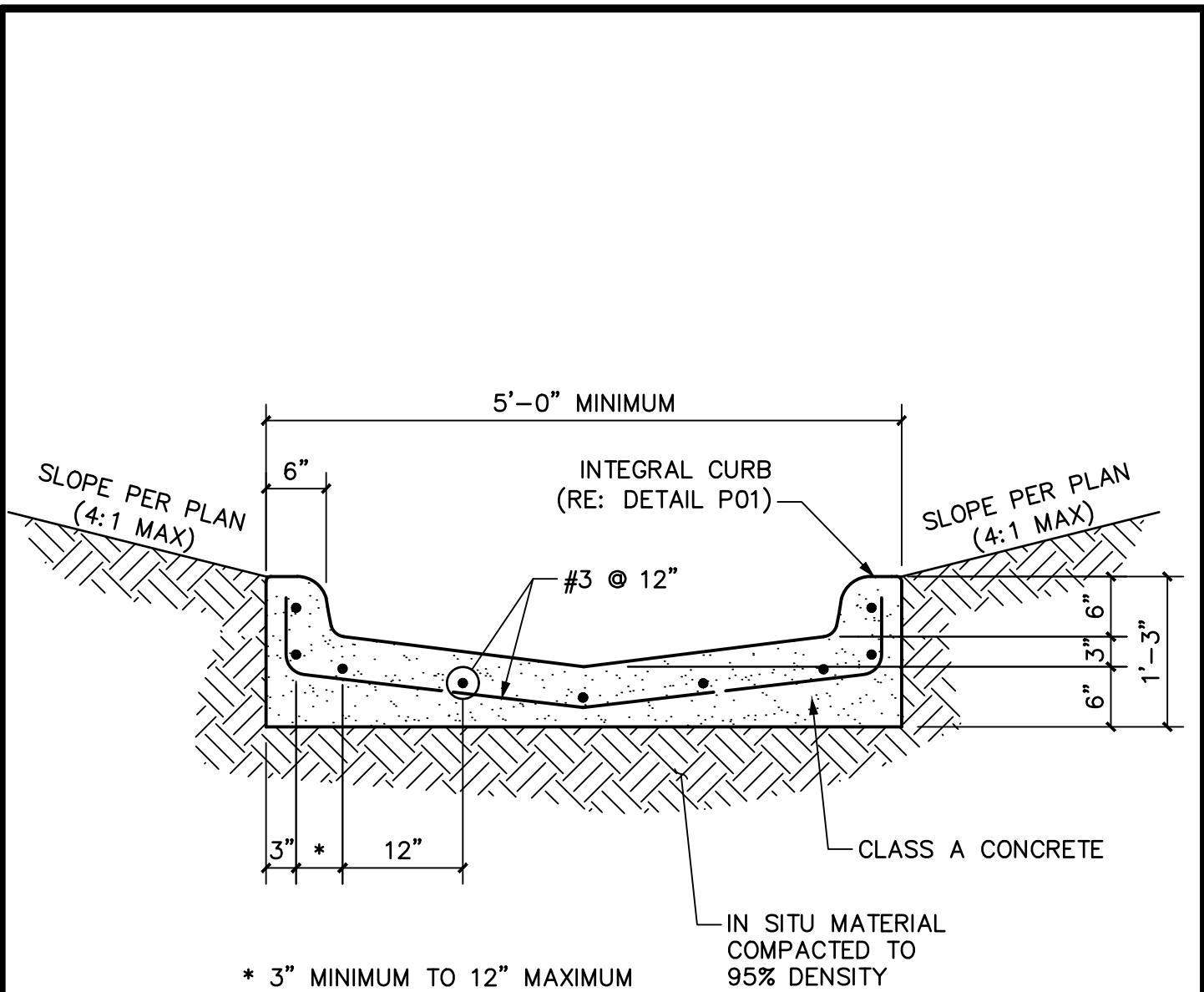

**NOTES:**

1. IF FLUME IS 7' OR WIDER, INSTALL 7' X 6" DIAMETER STEEL BOLLARDS (FILLED WITH CONCRETE) BURIED TO 4' DEPTH AT BOTH START AND END OF FLUME.
2. SLOPES SHALL BE STABILIZED WITH VEGETATION OR OTHER APPROVED METHODS.
3. THE WIDTH OF FLUME SHALL BE DETERMINED BASED UPON ENGINEERING CALCULATIONS.
4. ADEQUATE EROSION CONTROL MEASURES SHALL BE PROVIDED AT THE OUTFALL. CALCULATIONS SHALL BE PROVIDED.
5. REFER TO TXDOT ITEM 421 FOR CLASS A CONCRETE REQUIREMENTS.



**STANDARD CONSTRUCTION DETAIL**

**CURBED FLUME**

SCALE: 3/4"=1'-0"

REVISED:  
JANUARY 2022

D01

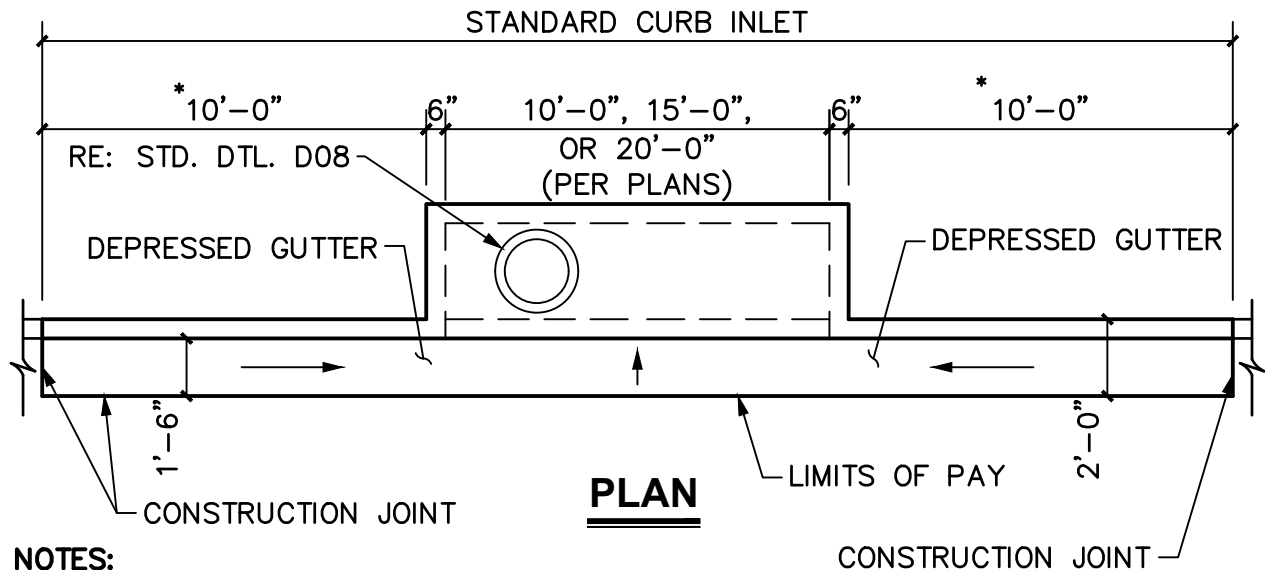

**NOTES:**

1. TOP OF INLET TO SLOPE 2% TOWARDS STREET OR PER PLAN.
2. CENTER SUPPORT BEAM REQUIRED FOR 15' AND 20' STANDARD CURB INLETS.
3. ADDITIONAL REINFORCING STEEL TO BE PLACED AROUND MANHOLE OPENING.
- \* 4. WING LENGTH MAY BE DECREASED BASED UPON SITE SPECIFIC CONDITIONS. CITY MUST APPROVE SHORTER LENGTH.
5. MANHOLE COVERS INSIDE OPENING SHALL BE 30". INLET TOP WILL NEED TO BE CAST IN PLACE IN ORDER TO ACCOMMODATE 30" OPENING/COVER.

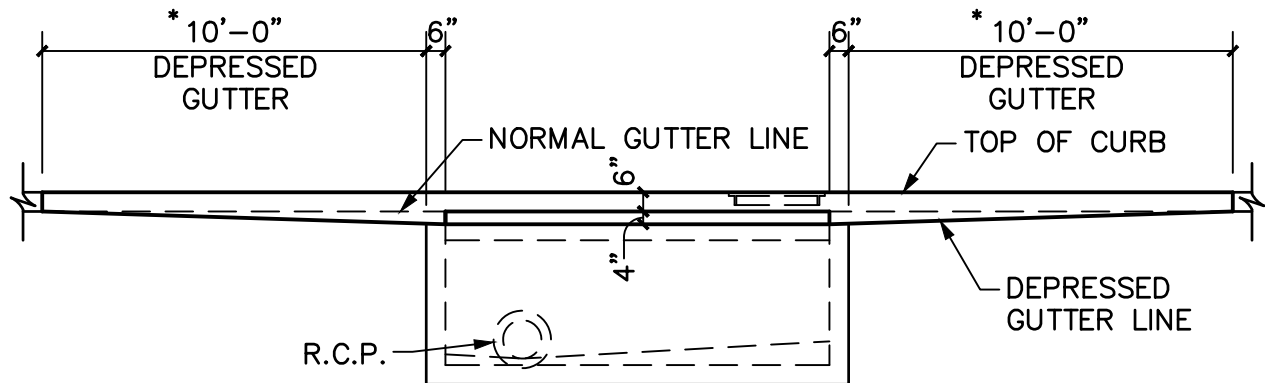

**NOTE:**

1. MANHOLE TO BE PLACED AT HIGH END OF INLET. TWO MANHOLES ARE REQUIRED ON 15' AND 20' INLETS ONLY IF THE INSIDE HEIGHT OF THE INLET IS LESS THAN 4 FEET. INLET DEPTH SHALL BE 4' OR 4.5' FEET FROM TOP OF CURB.

 DAYTON TEXAS	<b>STANDARD CONSTRUCTION DETAIL</b> <b>STANDARD CURB INLET</b> <b>SHEET 1 OF 2</b>	SCALE: 1"=5' REVISED: JANUARY 2022 D02
---	--	---

INCLUDING THE CITY OF DAYTON STANDARD CONSTRUCTION DETAIL IN PLANS DOES NOT RELIEVE THE SEALING ENGINEER OF THE RESPONSIBILITY FOR THE SPECIFIC DESIGN. THESE DETAILS SHOULD BE CONSIDERED MINIMUM STANDARDS WHICH THE SEALING ENGINEER MAY MODIFY TO MEET SITE SPECIFIC DESIGN REQUIREMENTS.

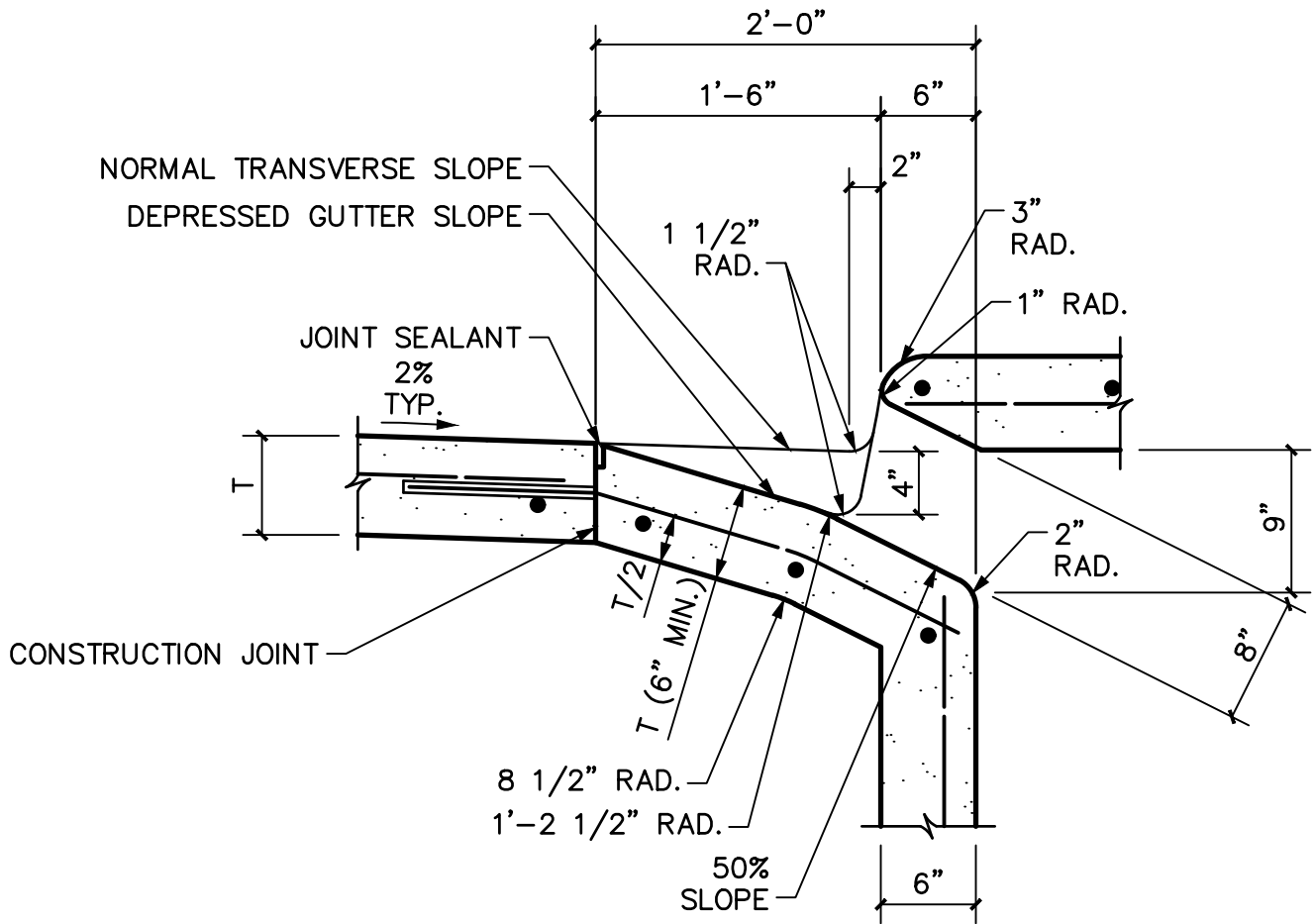

**THROAT SECTION**



**STANDARD CONSTRUCTION DETAIL**  
**STANDARD CURB INLET**  
**SHEET 2 OF 2**

SCALE: 1"=1'-0"

REVISED:  
 JANUARY 2022

D03

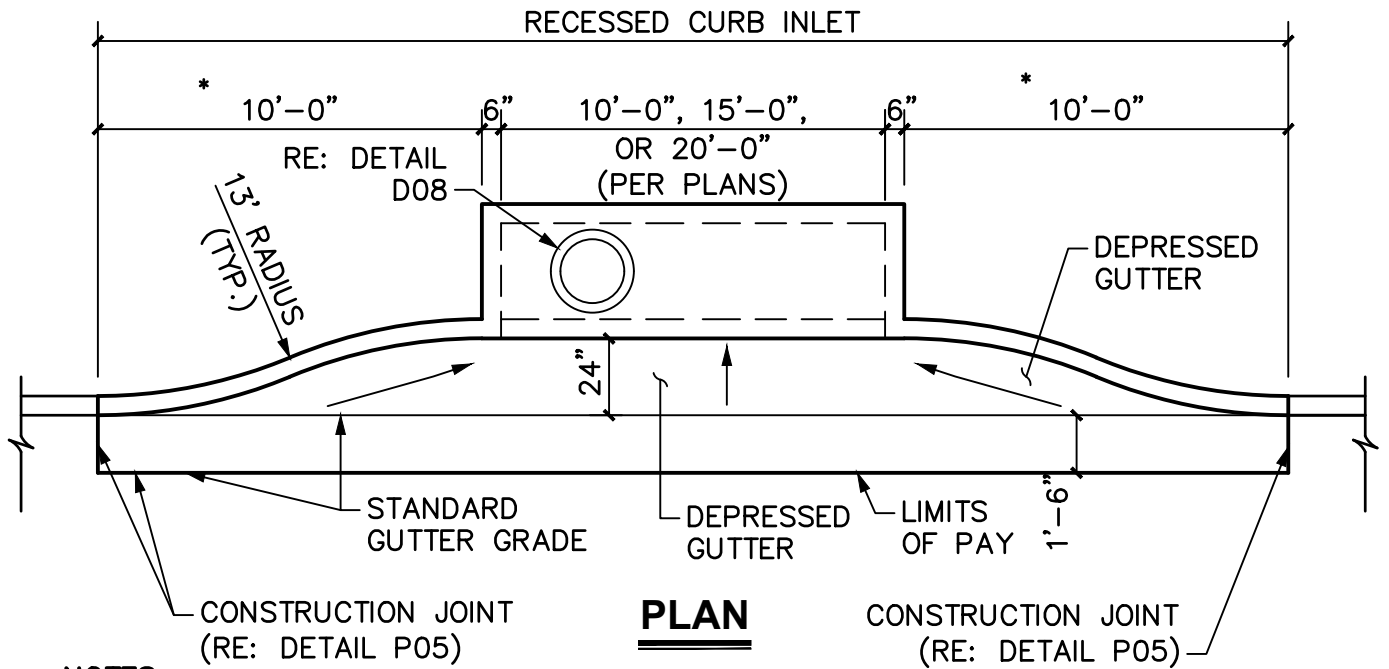

**NOTES:**

1. TOP OF INLET TO SLOPE 2% TOWARDS STREET OR PER PLAN.
2. CENTER SUPPORT BEAM REQUIRED FOR 15' AND 20' STANDARD CURB INLETS.
3. ADDITIONAL REINFORCING STEEL TO BE PLACED AROUND MANHOLE OPENING.
4. WING LENGTH MAY BE DECREASED BASED UPON SITE SPECIFIC CONDITIONS. CITY MUST APPROVE SHORTER LENGTH.
5. MANHOLE COVERS INSIDE OPENING SHALL BE 30". INLET TOP WILL NEED TO BE CAST IN PLACE IN ORDER TO ACCOMMODATE 30" OPENING/COVER.

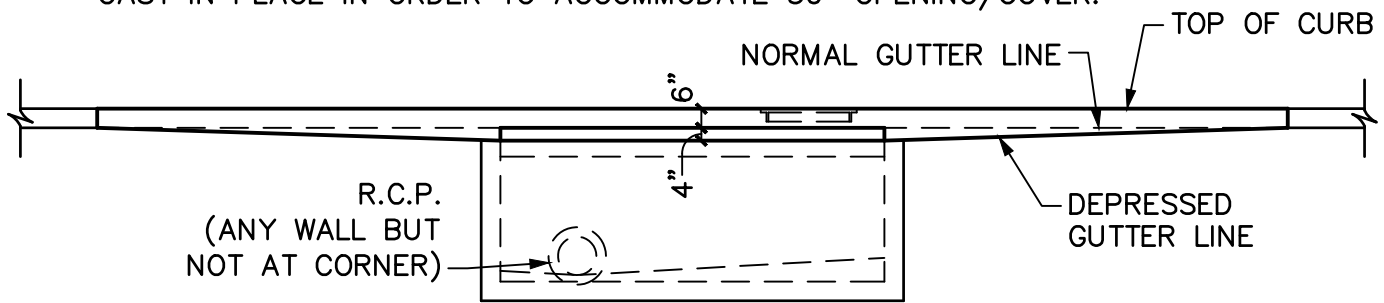

**NOTE:**

1. MANHOLE TO BE PLACED AT HIGH END OF INLET. TWO MANHOLES ARE REQUIRED ON 15' AND 20' INLETS ONLY IF THE INSIDE HEIGHT OF THE INLET IS LESS THAN 4 FEET. INLET DEPTH SHALL BE 4' OR 4.5' FEET FROM TOP OF CURB.

	<b>STANDARD CONSTRUCTION DETAIL</b> <b>RECESSED CURB INLET</b>	SCALE: 1"=5' REVISED: JANUARY 2022
	<b>SHEET 1 OF 2</b>	D04

INCLUDING THE CITY OF DAYTON STANDARD CONSTRUCTION DETAIL IN PLANS DOES NOT RELIEVE THE SEALING ENGINEER OF THE RESPONSIBILITY FOR THE SPECIFIC DESIGN. THESE DETAILS SHOULD BE CONSIDERED MINIMUM STANDARDS WHICH THE SEALING ENGINEER MAY MODIFY TO MEET SITE SPECIFIC DESIGN REQUIREMENTS.



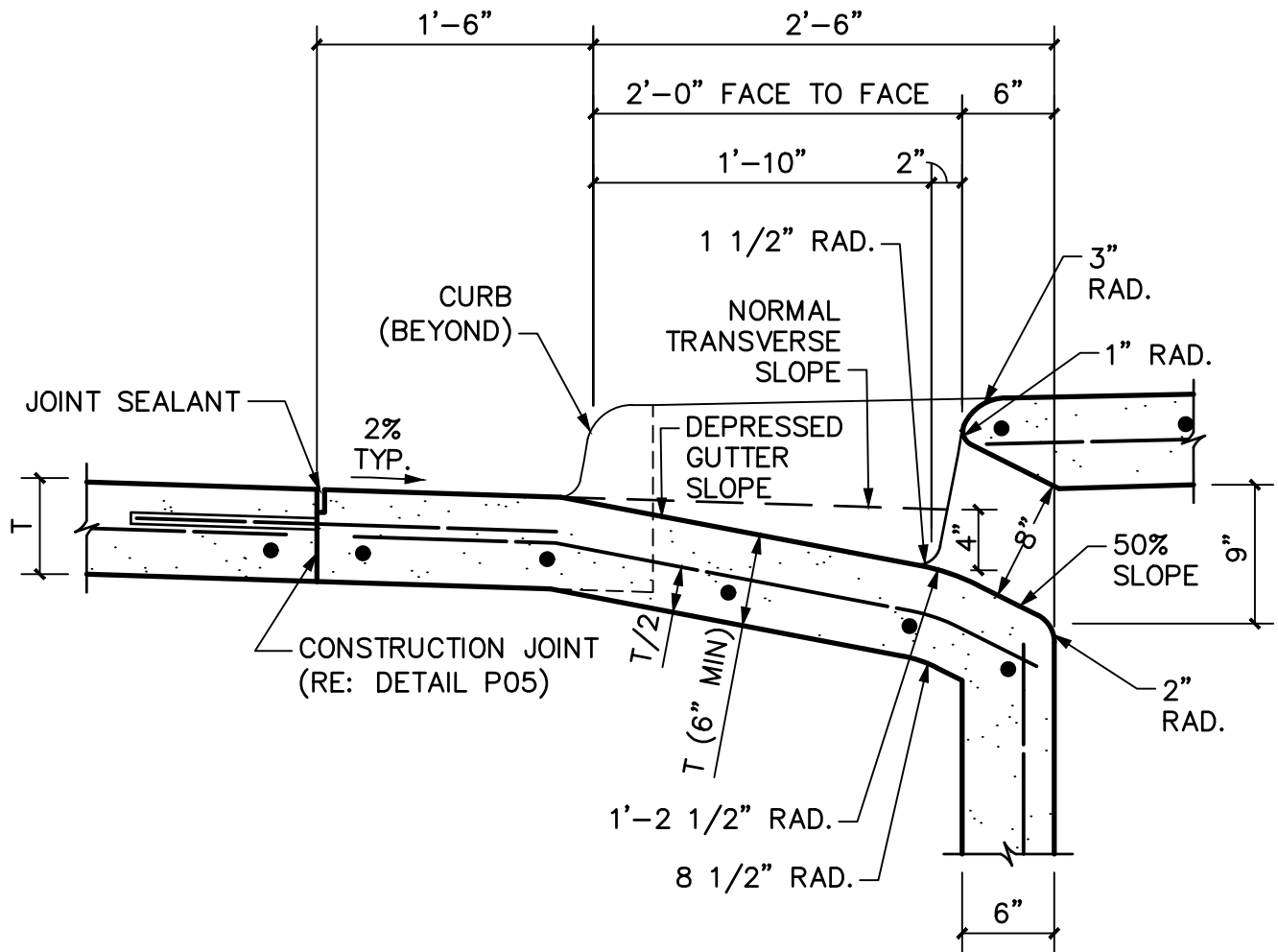

**THROAT SECTION**



**STANDARD CONSTRUCTION DETAIL  
RECESSED CURB INLET  
SHEET 2 OF 2**

SCALE: 1"=1'-0"

REVISED:  
JANUARY 2022

D05

INCLUDING THE CITY OF DAYTON STANDARD CONSTRUCTION DETAIL IN PLANS DOES NOT RELIEVE THE SEALING ENGINEER OF THE RESPONSIBILITY FOR THE SPECIFIC DESIGN. THESE DETAILS SHOULD BE CONSIDERED MINIMUM STANDARDS WHICH THE SEALING ENGINEER MAY MODIFY TO MEET SITE SPECIFIC DESIGN REQUIREMENTS.

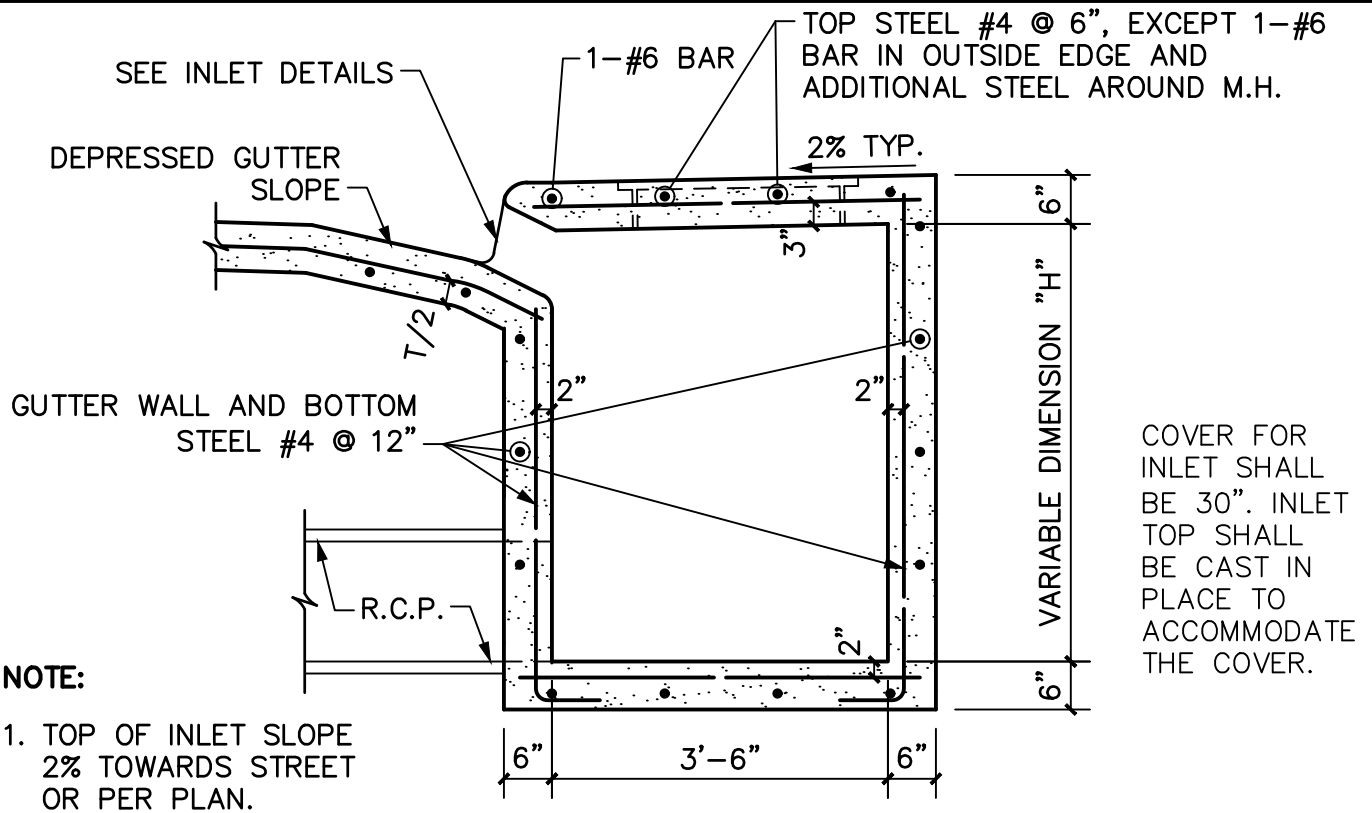

COVER FOR INLET SHALL BE 30". INLET TOP SHALL BE CAST IN PLACE TO ACCOMMODATE THE COVER.

## INLET SECTION FOR RECESSED AND STANDARD INLETS

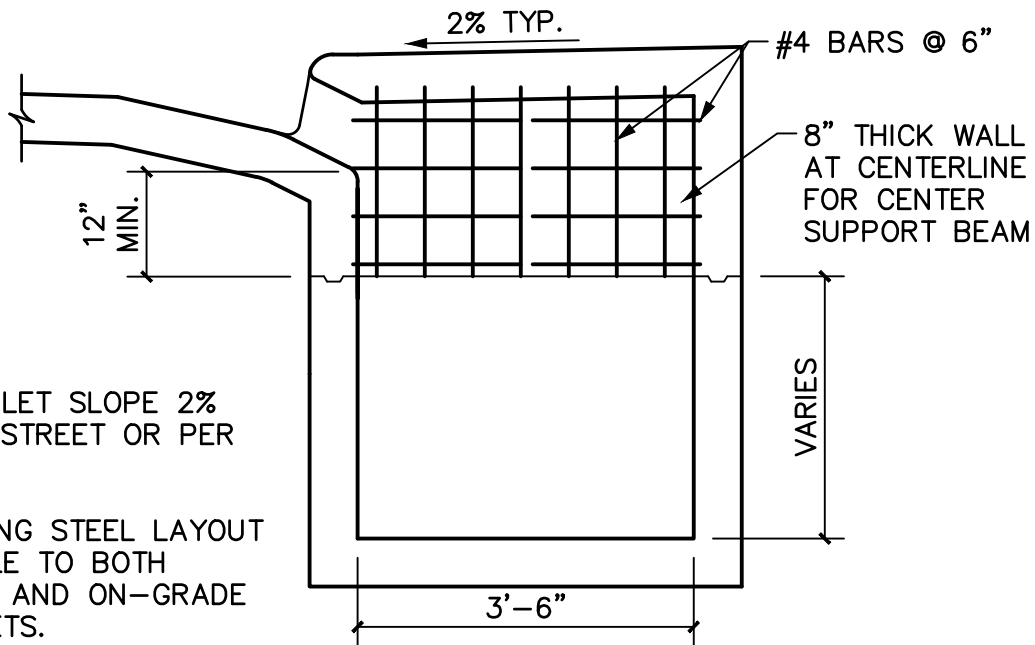

## CENTER SUPPORT BEAM FOR 15' & 20' RECESSED AND STANDARD INLETS



## STANDARD CONSTRUCTION DETAIL CENTER SUPPORT BEAM & INLET SECTION FOR RECESSED AND STANDARD INLETS

SCALE: 1/2"=1'-0"

REVISED:  
JANUARY 2022

D06

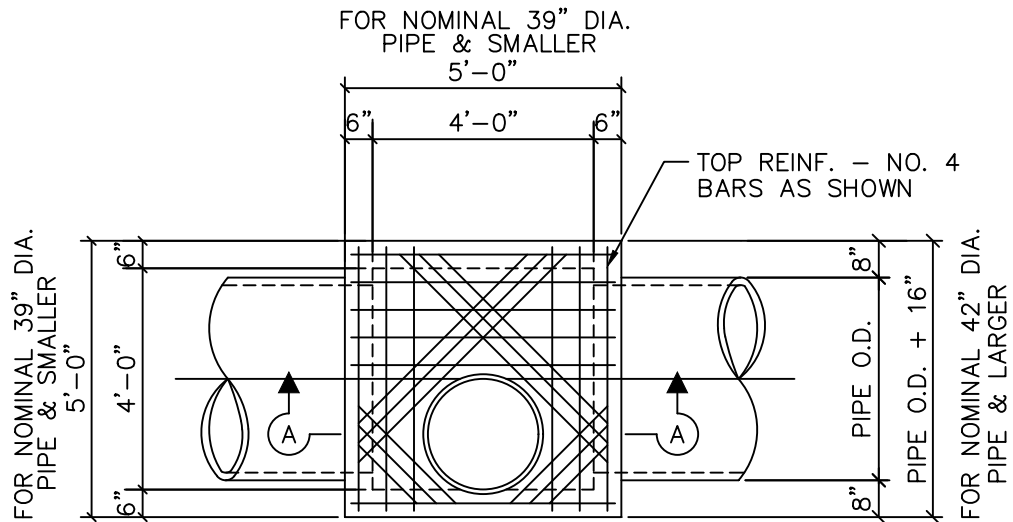

PLAN VIEW

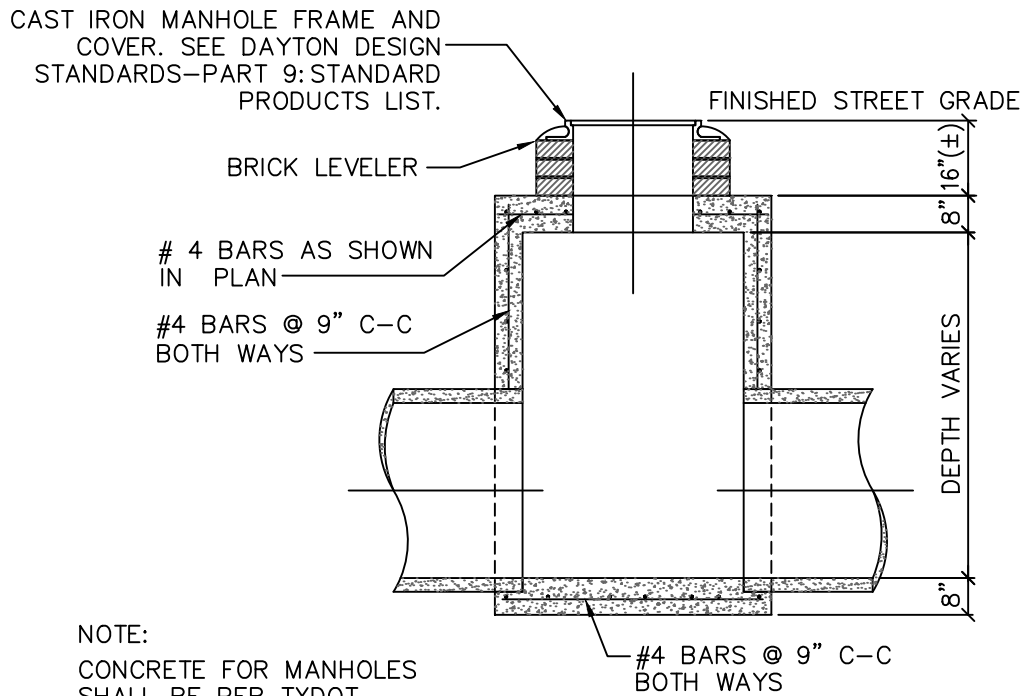

NOTE:  
CONCRETE FOR MANHOLES SHALL BE PER TXDOT ITEM 465.

SECTION A-A



STANDARD CONSTRUCTION DETAIL  
STANDARD SQUARE  
STORM DRAIN MANHOLE

SCALE: NTS

REVISED:  
JANUARY 2022

D07

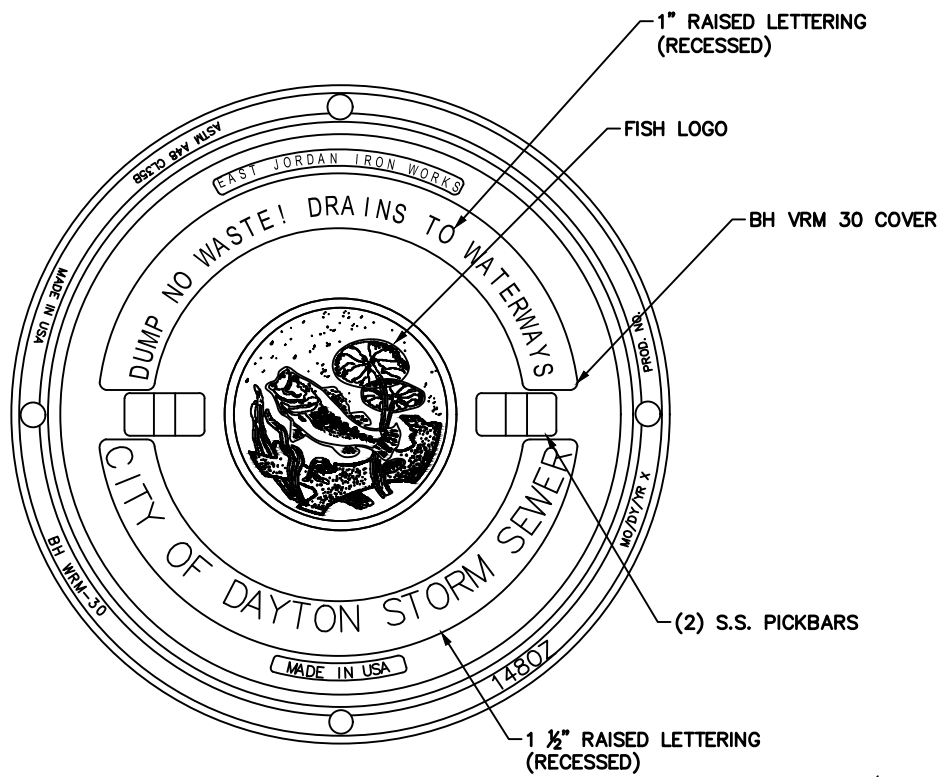

TOP VIEW

NO DUMPING LABELS/MEDALLIONS SHALL BE PLACED ON THE FRONT OF THE CURB INLET

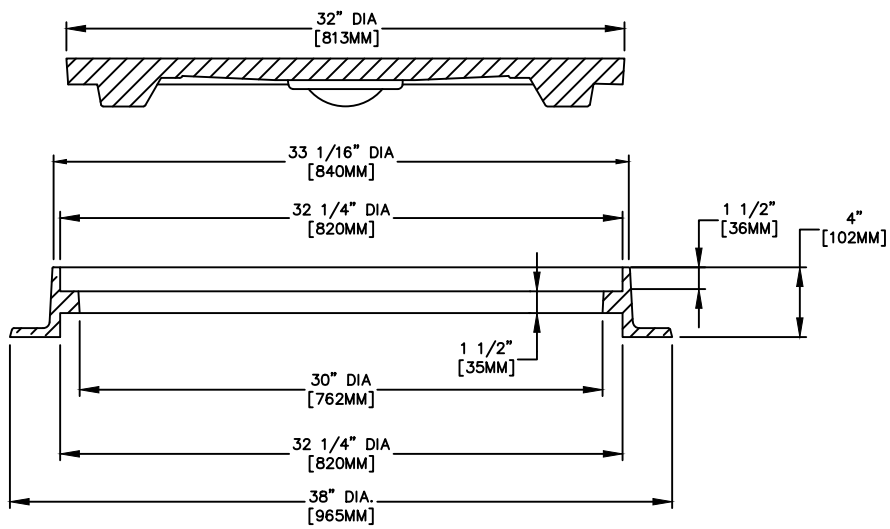

SECTION VIEW

- NOTES:**
1. MANHOLE LID AND FRAME SHALL BE CAST IRON.

	<p><b>STANDARD CONSTRUCTION DETAIL</b></p> <p><b>INLET LID DETAIL</b></p>	<p>SCALE: 1"=1'-0"</p> <p>REVISED: JANUARY 2022</p> <p>D08</p>
---	---	--

INCLUDING THE CITY OF DAYTON STANDARD CONSTRUCTION DETAIL IN PLANS DOES NOT RELIEVE THE SEALING ENGINEER OF THE RESPONSIBILITY FOR THE SPECIFIC DESIGN. THESE DETAILS SHOULD BE CONSIDERED MINIMUM STANDARDS WHICH THE SEALING ENGINEER MAY MODIFY TO MEET SITE SPECIFIC DESIGN REQUIREMENTS.

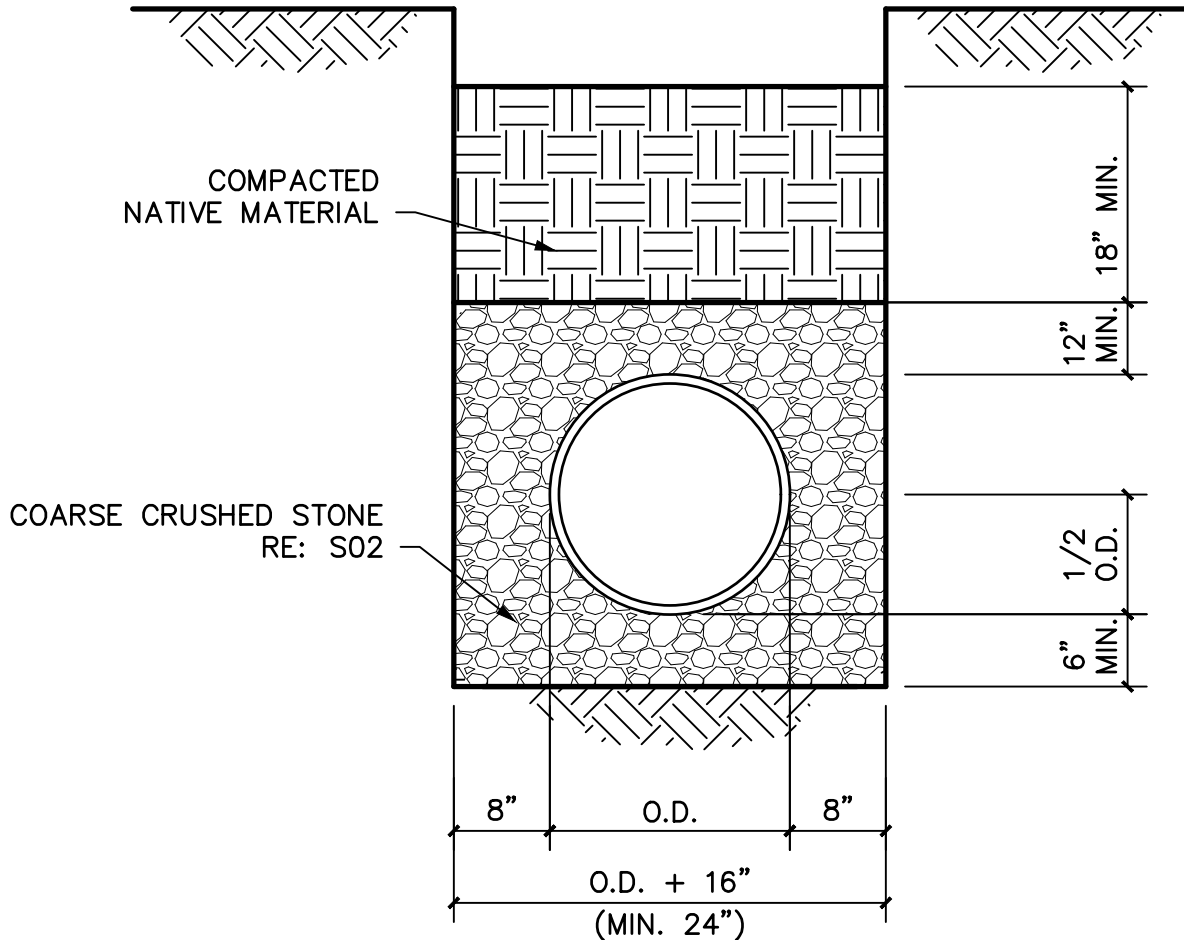

## CEMENT STABILIZED SAND

**NOTES:**

1. UTILIZE CEMENT STABILIZED SAND EMBEDMENT FOR RCP STORM DRAIN INSTALLATIONS. MINIMUM 2.5 SACK MIX.
2. MATERIALS AND INSTALLATION SHALL BE IN ACCORDANCE WITH CITY OF HOUSTON STANDARD SPECIFICATION 02320.
3. BEDDING DEPTH MEASURED FROM OUTSIDE THE PIPE BELL.



STANDARD CONSTRUCTION DETAIL

**EMBEDMENT (STORM)**

SCALE: 3/4"=1'-0"

REVISED:  
JANUARY 2022

D09

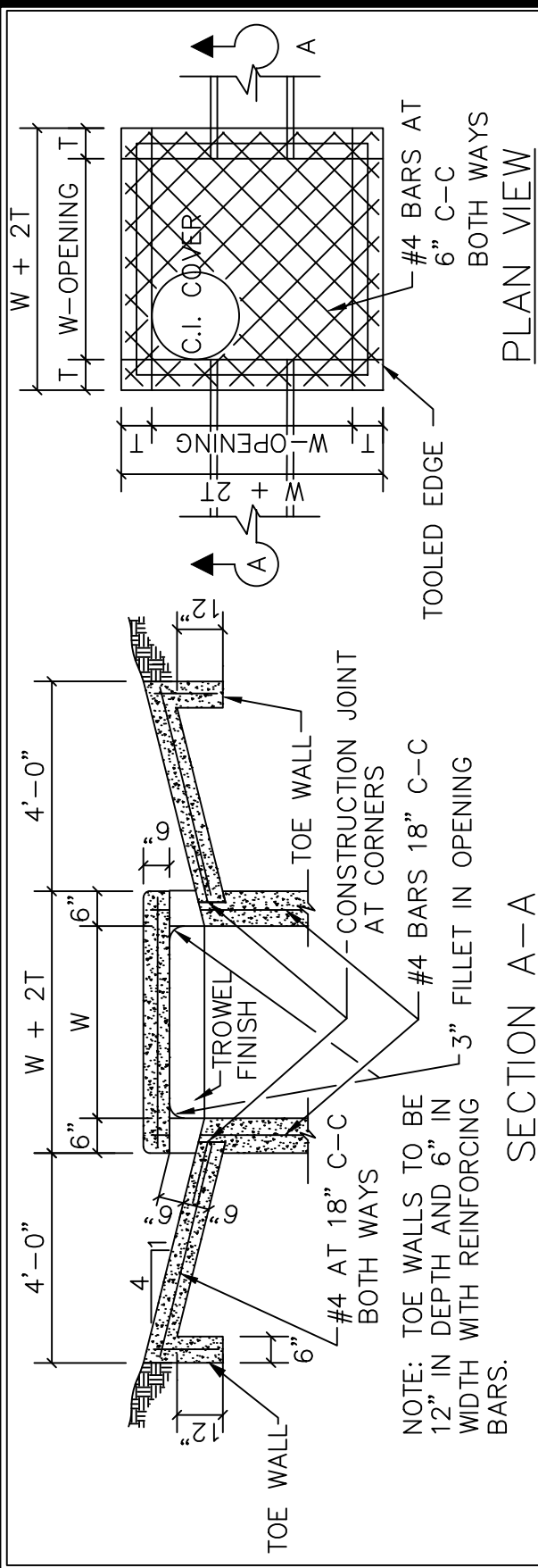

NOTE: TOE WALLS TO BE 12" IN DEPTH AND 6" IN WIDTH WITH REINFORCING BARS.

**NOTES:**

1. MATERIAL AND WORKMANSHIP SHALL CONFORM WITH THE REQUIREMENTS OF TXDOT ITEM 465 FOR STANDARD CONCRETE MANHOLES.
2. CONCRETE FOR DROP INLETS SHALL BE 4200 PSI.
3. LAYERS OF REINFORCING STEEL NEAREST THE INTERIOR AND EXTERIOR SURFACES SHALL HAVE A COVER OF 2" TO THE CENTER OF BARS, UNLESS OTHERWISE NOTED.
4. FOR DETAILS OF REINFORCING TO LOWER PORTIONS OF INLET, SEE APPROPRIATE SQUARE MANHOLE DETAILS.
5. DEPTH OF DROP INLET FROM FINISHED GRADE TO FLOW LINE OF INLET IS VARIABLE. APPROXIMATE DEPTH SHALL BE SHOWN ON PLANS AT LOCATION OF INLET.
6. ALL STANDARD DROP INLETS SHALL HAVE ONE OPENING ON EACH SIDE UNLESS SHOWN ON PLANS.
7. DECK MAY BE REINFORCED THE SAME AS STANDARD SQUARE STORM DRAIN MANHOLE.
8. CAST IRON FRAME AND COVER, TVI&S #679 WITH 1/2" TO 5/8" DIAMETER PICK BAR, OR APPROVED EQUAL.
9. MANHOLE LIDS SHALL BE BOLTED AND CHAINED TO THE INLET BOX USING 2' OF 3/8" STOCK CHAIN AND 3/8" CARRIAGE BOLTS.

INLET SIZE	T	W
2' SQUARE	7"	2'-0"
4' SQUARE	7"	4'-0"
5' SQUARE	8"	5'-0"
6' SQUARE	9"	6'-0"
7' SQUARE	9"	7'-0"
8' SQUARE	9"	8'-0"

FOR LOWER PORTION OF 2' SQUARE DROP INLET USE REINF. STEEL DETAILS OF 4' SQUARE MANHOLE AND ELIMINATE INLET RING AND COVER.



**STANDARD CONSTRUCTION DETAIL**

**STANDARD DROP INLET**

REVISED:  
**JANUARY 2022**  
 P01A

INCLUDING THE CITY OF DAYTON STANDARD CONSTRUCTION DETAIL IN PLANS DOES NOT RELIEVE THE SEALING ENGINEER OF THE RESPONSIBILITY FOR THE SPECIFIC DESIGN. THESE DETAILS SHOULD BE CONSIDERED MINIMUM STANDARDS WHICH THE SEALING ENGINEER MAY MODIFY TO MEET SITE SPECIFIC DESIGN REQUIREMENTS.

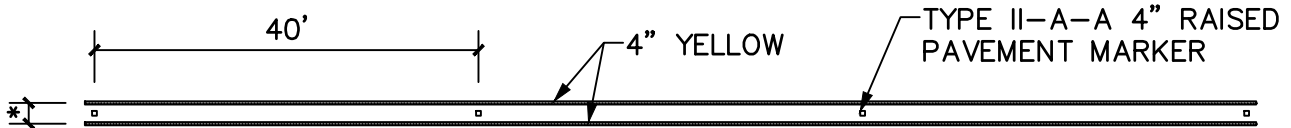

\* RE: TxDOT PM(2)-10 DETAIL "B"

## DOUBLE YELLOW LINE (PAVEMENT MARKINGS)

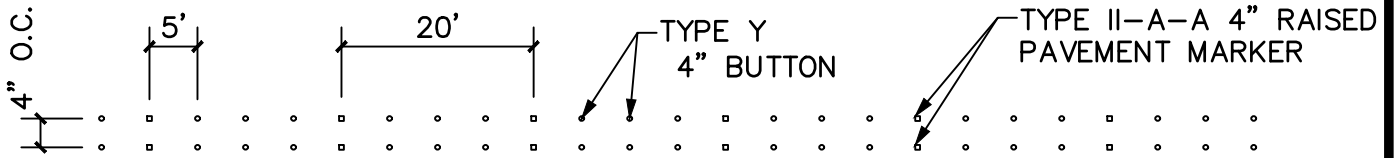

## DOUBLE YELLOW LINE (BUTTONS, RAISED PAVEMENT MARKERS)

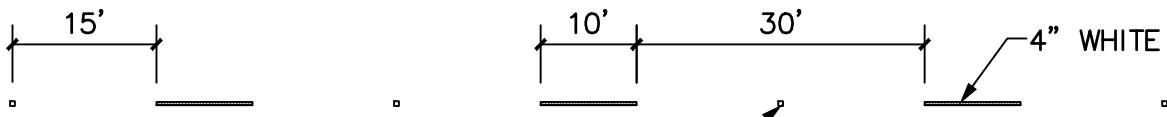

TYPE II-C-R 4" RAISED PAVEMENT MARKER  
(USE TYPE I-C ON UNDIVIDED ROADWAYS)

NOTE: 1-WAY RAISED PAVEMENT MARKINGS REFLECTION COLOR SHALL BE RED FOR OPPOSING TRAFFIC AND WHITE WITH TRAFFIC.

## BROKEN WHITE LANE LINE



## WHITE OR YELLOW EDGE LINE

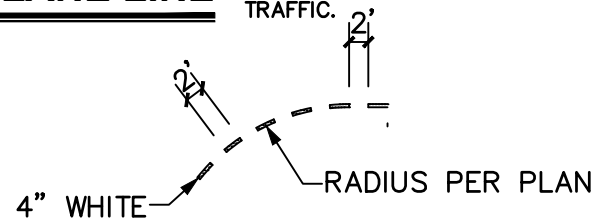

## LEFT TURN "PUPPY TRACKS"

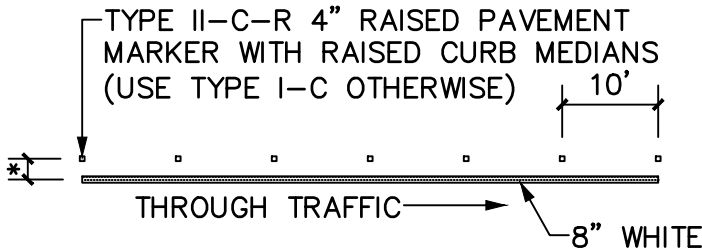

\* RE: TxDOT PM(4)-03 DETAIL "C"

## LEFT TURN BAY LINE

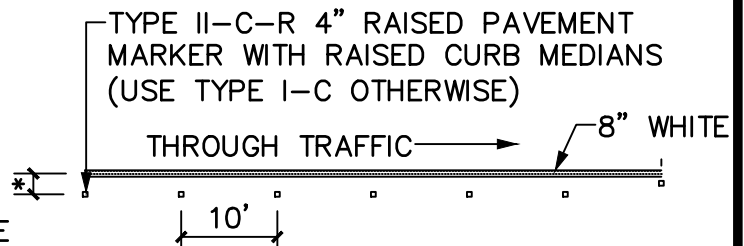

\* RE: TxDOT PM(4)-03 DETAIL "C"

## RIGHT TURN BAY LINE

### NOTES:

1. ALL STRIPING, ARROWS AND WORDS ON PAVEMENT SHALL BE THERMOPLASTIC UNLESS OTHERWISE NOTED IN PLANS.





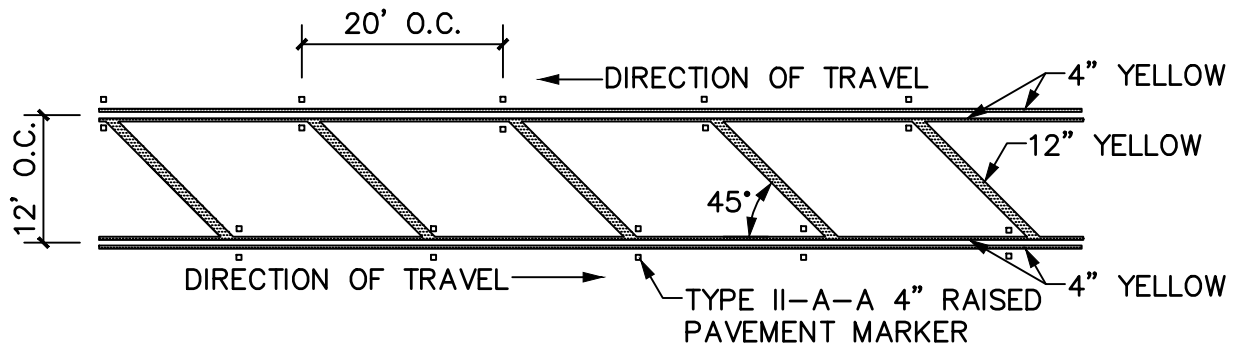

**OPPOSING TRAFFIC GORE DETAIL**

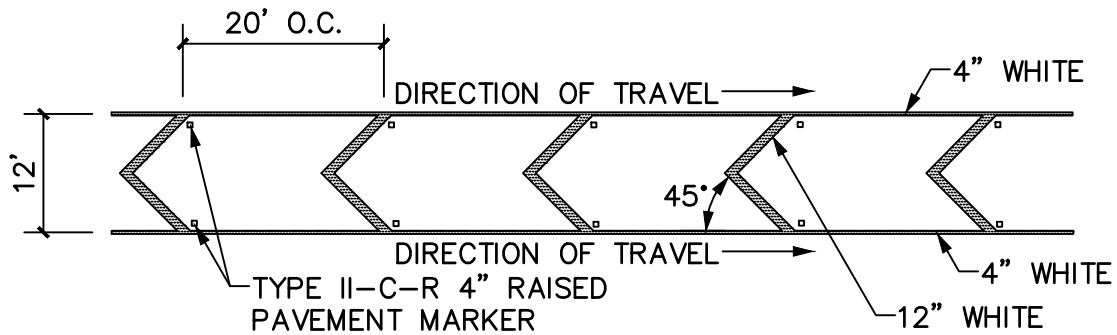

**NEUTRAL AREA CHANNELIZATION**

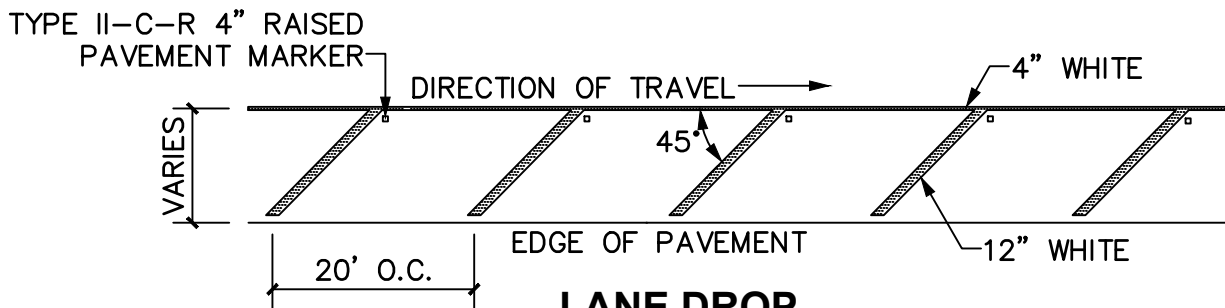

**LANE DROP**

**NOTES:**

1. REFER TO TxDOT PM(4)-03 DETAIL "A" FOR DIMENSION BETWEEN PAVEMENT MARKINGS AND MARKERS.



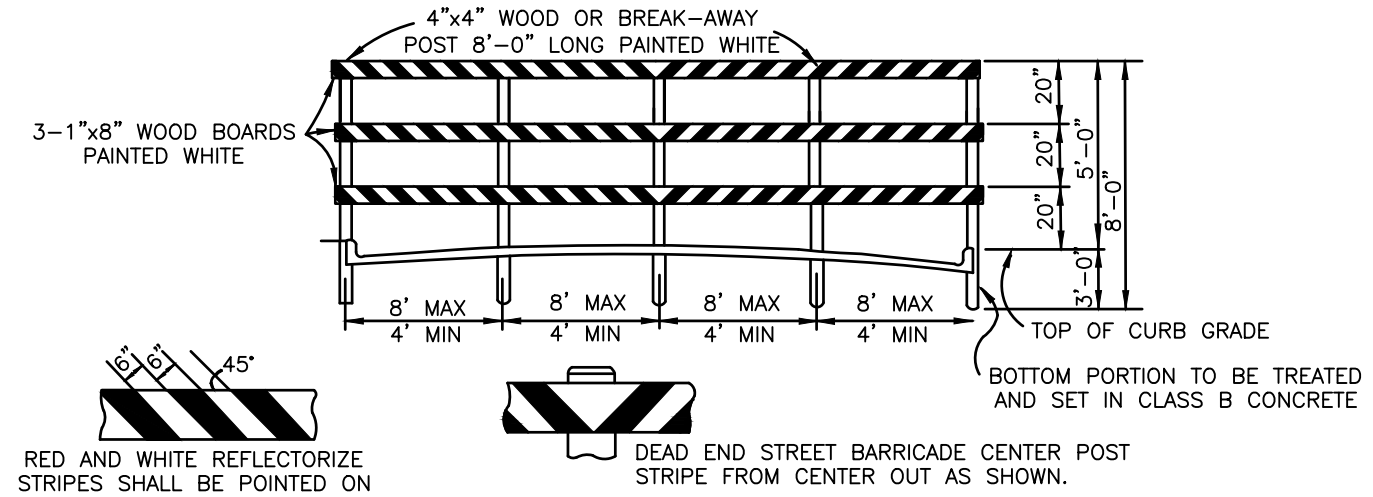

ALL HORIZONTAL MEMBERS TO BE ATTACHED TO POSTS AS SHOWN

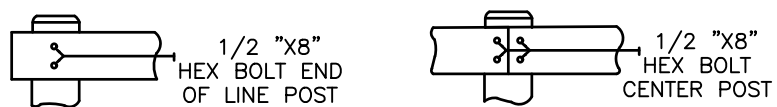

TYPE III BARRICADE

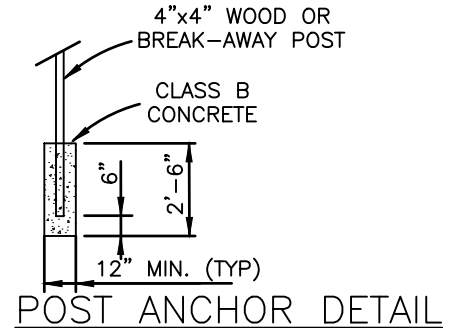
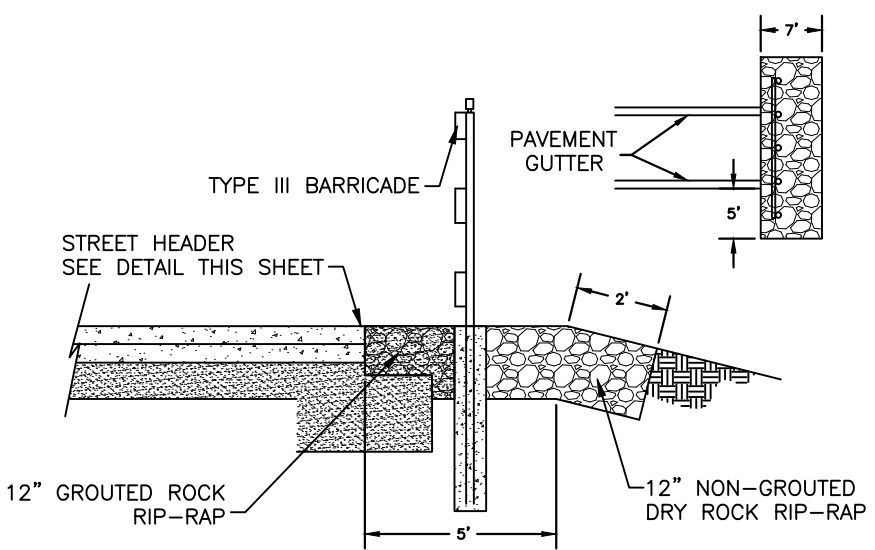

BARRICADE AT STREET HEADER DETAIL

**NOTES:**

1. ALL BARRICADES SHALL BE IN ACCORDANCE WITH THE LATEST REVISION OF THE TEXAS MANUAL ON UNIFORM TRAFFIC CONTROL DEVICES (TMUTCD) AND THE STANDARD HIGHWAY SIGN DESIGNS FOR TEXAS (SHSD).
2. BARRICADE MUST COVER ENTIRE WIDTH OF PAVED ROADWAY OR FIRELANE SURFACE.
3. BARRICADES SHALL BE DESIGNED AND CONSTRUCTED TO THE STANDARDS OF THE COMPLIANT WORK ZONE TRAFFIC CONTROL DEVICE LIST.
4. BARRICADE STRIPING MATERIAL SHALL BE RED AND WHITE HIGH INTENSITY REFLECTIVE SHEETING.
5. DIAGONAL STRIPING SHALL BE PLACED IN A MANNER THAT DIRECTS TRAFFIC IN THE APPROPRIATE DIRECTION OF TRAVEL.
6. PROPOSED BARRICADE STRIPING SHALL BE APPROVED BY THE CITY PRIOR TO PLACEMENT OF BARRICADE.

 <p>DAYTON TEXAS</p>	<p><b>STANDARD CONSTRUCTION DETAIL</b></p> <p><b>ROAD CLOSED BARRICADE</b></p>	<p>SCALE: NTS</p> <p>REVISED: JANUARY 2022</p> <p>T03</p>
---	--	---

INCLUDING THE CITY OF DAYTON STANDARD CONSTRUCTION DETAIL IN PLANS DOES NOT RELIEVE THE SEALING ENGINEER OF THE RESPONSIBILITY FOR THE SPECIFIC DESIGN. THESE DETAILS SHOULD BE CONSIDERED MINIMUM STANDARDS WHICH THE SEALING ENGINEER MAY MODIFY TO MEET SITE SPECIFIC DESIGN REQUIREMENTS.

**NOTES:**

1. ALL SIGNAGE SHALL BE IN ACCORDANCE WITH THE LATEST REVISIONS OF THE TEXAS MANUAL ON UNIFORM TRAFFIC CONTROL DEVICES AND THE STANDARD HIGHWAY SIGN DESIGN FOR TEXAS (SHSD).
2. LOCATIONS SHOWN FOR SIGNAGE ARE APPROXIMATE; FINAL LOCATIONS MAY CHANGE DUE TO POST CONSTRUCTION CONDITIONS AND PRESENCE OF OTHER PHYSICAL FEATURES. FINAL LOCATION OF ALL SIGNAGE SHALL BE FIELD VERIFIED WITH CITY PRIOR TO INSTALLATION.
3. ALL SIGNS SHALL BE DIAMOND GRADE INTENSITY AND THE SIZES SHALL BE STANDARD UNLESS OTHERWISE NOTED.
4. ALL TRAFFIC SIGNS, POSTS, AND MATERIALS SHALL BE INSTALLED PER DETAIL THIS SHEET.
5. FOR STOP SIGNS THAT WILL ACCEPT FUTURE STREET SIGNS, EXTEND POST ABOVE STOP SIGN SO THAT 2 HOLES ARE AVAILABLE FOR MOUNTING. FOR ALL OTHERS, POST SHALL NOT EXTEND ABOVE SIGN.

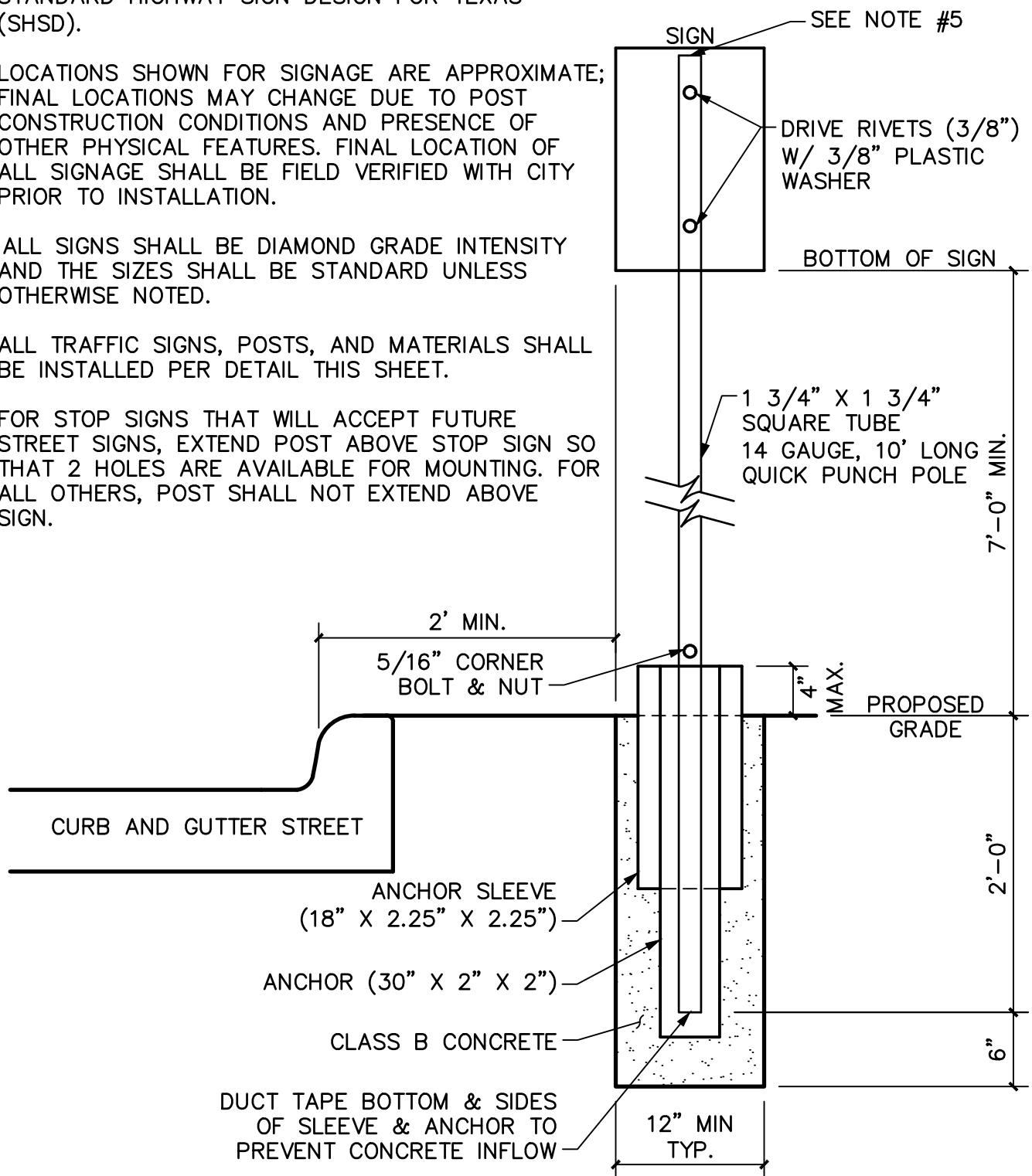

**STANDARD CONSTRUCTION DETAIL**

**SIGN POST**

SCALE: 1"=1'

REVISED:  
JANUARY 2022

T04

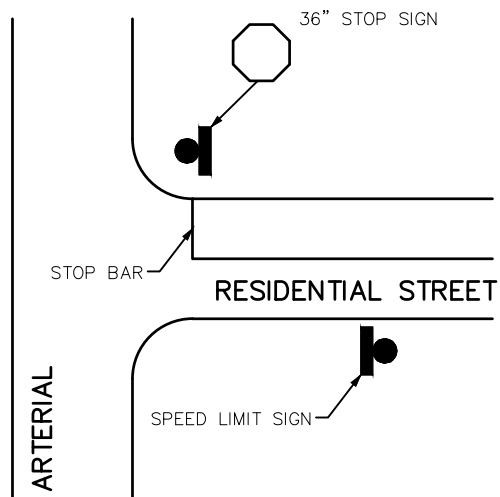

RESIDENTIAL STREET INTERSECTING ARTERIAL

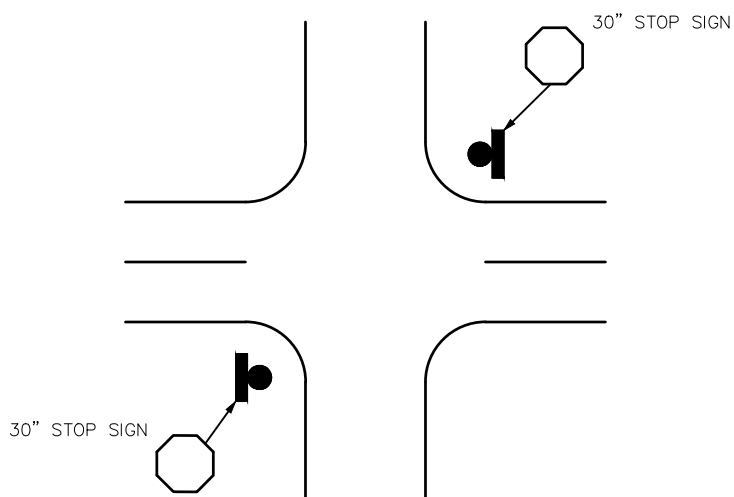

RESIDENTIAL 2-WAY STOP

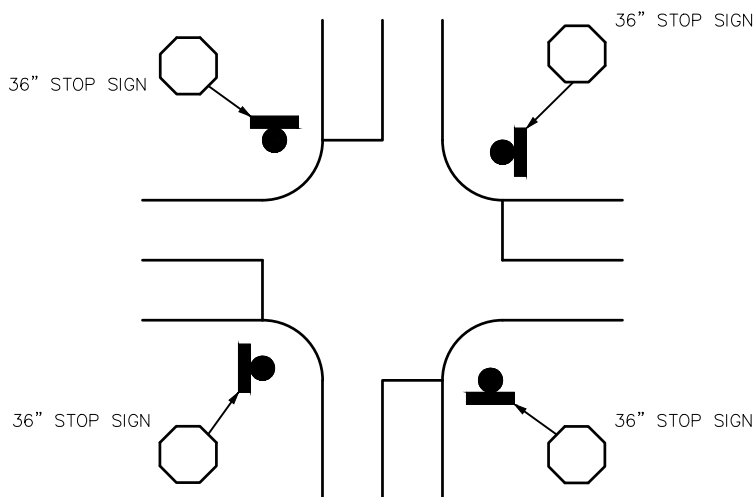

RESIDENTIAL 4-WAY STOP



**STANDARD CONSTRUCTION DETAIL**

**STOP SIGNS AND STOP BARS**

SCALE: 1/2"=1'

REVISED:  
JANUARY 2022

T05

**STREET NAME BLADE GENERAL NOTES**

1. **LOCATION:** NINE-INCH (9") EXTRUDED BLADES SHALL BE USED AT ALL INTERSECTIONS.

2. **BLADE REQUIREMENTS:** NINE-INCH (9") EXTRUDED BLADE SHALL BE ALUMINUM. ALL STREET BLADES ARE REQUIRED TO BE ON A TWELVE INCH (12") MOUNTING BRACKET WITH A SET SCREW THROUGH THE STREET BLADE TO AFFIX IT TO THE POLE

3. **LETTERING ALIGNMENT:**

- A. STREET NAME IS LEFT JUSTIFIED.
- B. BLOCK NUMBERS ARE LOCATED IN UPPER RIGHT CORNER.
- C. ABBREVIATED STREET DESIGNATIONS ARE LOCATED IN LOWER RIGHT CORNER.

4. **LETTERING FOR NINE-INCH (9") EXTRUDED BLADES:**

- A. LETTERS SHALL BE COMPOSED OF A COMBINATION OF LOWER-CASE LETTERS WITH INITIAL UPPER-CASE LETTERS.
- B. FONT IS FEDERAL HIGHWAY SERIES B OR SERIES C (MANUFACTURER WILL DETERMINE BEST TO USE BASED ON LENGTH OF BLADE AND LENGTH OF NAME).
- C. LETTERS AND NUMBERS IN STREET NAME ARE SIX-INCH (6") TALL.
- D. LETTERS IN ABBREVIATED STREET DESIGNATION ARE THREE-INCH (3") TALL (I.E., LN, PKWY, DR, CT, ETC).
- E. BLOCK NUMBERS ARE THREE-INCH (3") TALL.

5. **SIGN SHEETING AND COLORS:**

- A. HIGH INTENSITY SHEETING.
- B. BACKGROUND SHALL BE ~~BLUE~~ PURPLE.
- C. LEGEND SHALL BE WHITE.
- D. ~~CITY OF DAYTON LOGO SHALL BE LEFT JUSTIFIED.~~



PMS 268C

CMYK	RGB
C = 79	R = 77
M = 100	G = 25
Y = 0	B = 121
K = 20	

6. **NO OUTLET STREETS:**

- A. FOR A STREET WITH ONLY ONE CUL-DE-SAC END (TYPICAL) A STANDARD W 14-2A "NO OUTLET" SHALL BE MOUNTED OVER THE STREET NAME BLADE.
- B. IN THE CASE OF A STREET WITH TWO CUL-DE-SAC ENDS, TWO (2) STANDARD W 14-2A "NO OUTLET" SIGNS SHALL BE MOUNTED OVER THE STREET NAME BLADE PLACED IN THE APPROPRIATE DIRECTIONS.

7. **BLOCK NUMBERS:**

- A. DEVELOPERS AND CONTRACTORS ORDERING SIGNS SHOULD CONTACT PUBLIC WORKS AT (936) 258 -2642. BLOCK NUMBERS ARE REQUIRED ON ALL STREET NAME BLADES, EVEN IF NO HOUSES/BUILDINGS FRONT ONTO THE STREET.

STANDARD CONSTRUCTION DETAIL

GENERAL NOTES SIGNS

SCALE: 1/2"=1'

REVISED: JAN 2023

T06

FIN-A4 BK  
 PER BRANDON INDUSTRIES, INC. STANDARDS  
 (OR APPROVED EQUAL)  
 8"H x 4.75"W

H 0936DS-L  
 PER BRANDON INDUSTRIES, INC. STANDARDS  
 (OR APPROVED EQUAL)  
 9" EXTRUDED BLADE (52" TYPICAL)

Stevenson 100 Dr

Hawks 300 Dr

2WAYARM24 BK  
 PER BRANDON INDUSTRIES, INC. STANDARDS  
 (OR APPROVED EQUAL)



HIRI-1/30 BK  
 PER BRANDON INDUSTRIES, INC. STANDARDS  
 (OR APPROVED EQUAL)  
 36" TYPICAL  
 30" RESIDENTIAL 2-WAY STOP  
 SIGN SHALL HAVE A BLACK BACK

CP4X14 BK  
 PER BRANDON INDUSTRIES, INC. STANDARDS  
 (OR APPROVED EQUAL)  
 4" O.D.

SB-94 BK  
 PER BRANDON INDUSTRIES, INC. STANDARDS  
 (OR APPROVED EQUAL)  
 16"H x 13"W

USE BREAK AWAY KIT  
 SEE DETAIL FOR SUGGESTED FOUNDATION

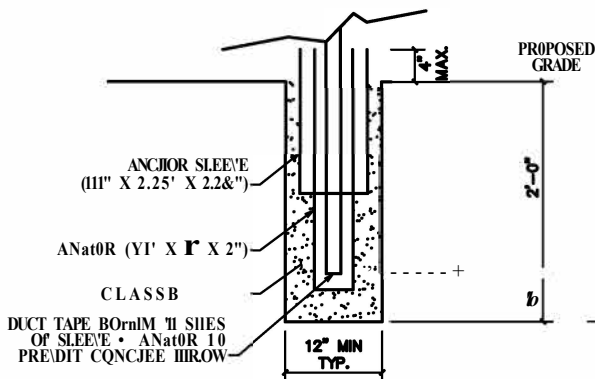

FOUNDATION DETAIL



STANDARD CONSTRUCTION DETAIL  
 STREET NAME BLADE AND STOP SIGN

SCALE: NTS  
 RE1SED: MAY 2019

T07

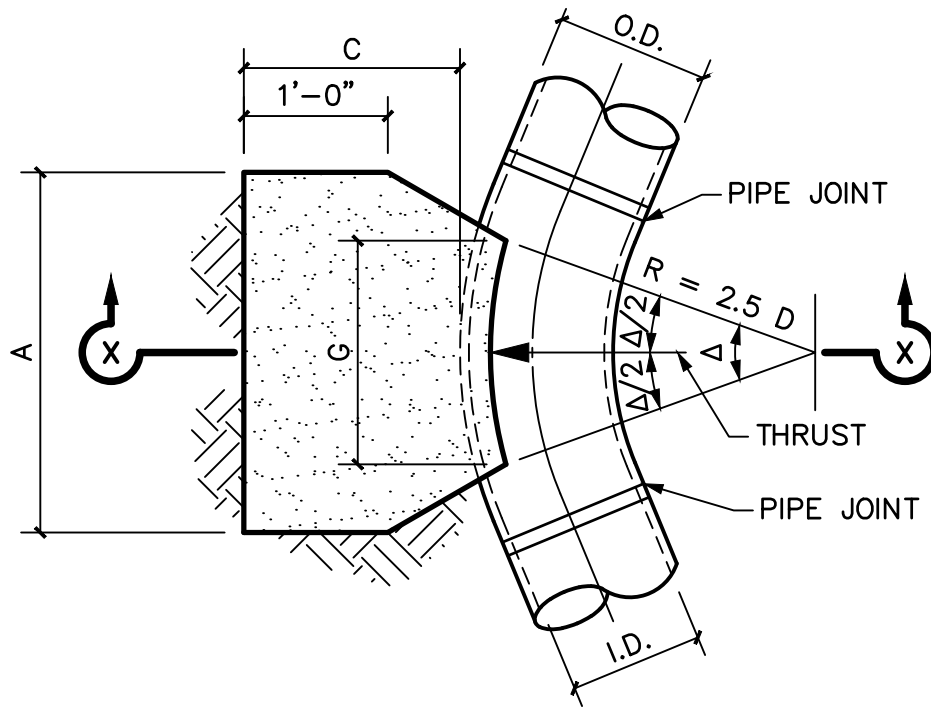

**PLAN**

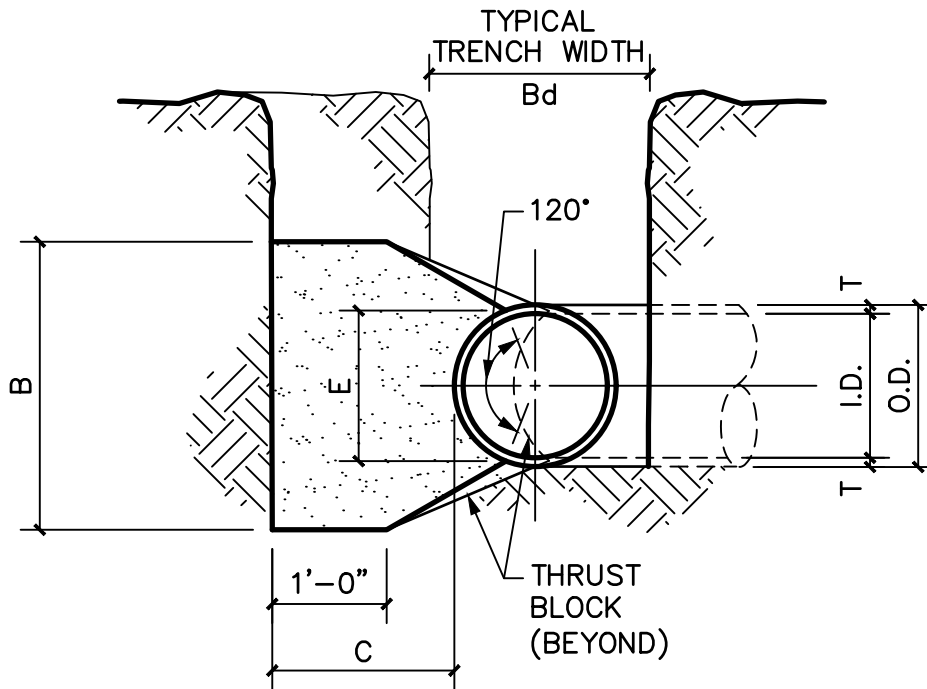

**SECTION X-X**

**NOTES:**

1. REFER TO STANDARD DETAIL W02 AND W03 FOR TABLES OF DIMENSIONS AND QUANTITIES.
2. REFER TO STANDARD DETAIL W05 FOR GENERAL NOTES.



**STANDARD CONSTRUCTION DETAIL  
HORIZONTAL THRUST BLOCK AT PIPE BEND  
SHEET 1 OF 3**

SCALE: 3/4"=1'-0"

REVISED:  
JANUARY 2022

W01



I.D. (IN.)	T (IN.)	$\Delta = 11.25^\circ$ C (IN.)	$\Delta \geq 22.50^\circ$ C (IN.)	E (IN.)
4,6,8	0.4	1.5	1.5	0.9
10,12	0.5	1.5	1.5	1.2
16,18	0.6	1.5	1.5	1.6
20	0.7	1.5	1.5	1.8
24	0.9	1.5	1.5	2.1
30	2.9	1.5	1.9	2.6
36	4.5	1.5	2.3	3.3
42	5.0	1.8	2.6	3.8
48	5.5	2.0	3.0	4.3
54	6.0	2.3	3.4	4.8
60	6.5	2.5	3.8	5.3
66	6.8	2.8	4.1	5.7
72	7.5	3.0	4.5	6.3
78	7.5	3.3	4.9	6.7
84	8.0	3.5	5.3	7.2
90	8.5	3.8	5.6	7.7
96	9.0	4.0	6.0	8.2

I.D. (IN.)	$\Delta = 11.25^\circ$							
	G (FT.)	THRUST (TONS)	EARTH			ROCK		
			A (FT.)	B (FT.)	VOL. (C.Y.)	A (FT.)	B (FT.)	VOL. (C.Y.)
4,6,8	0.4	1.0	1.0	1.5	0.1	1.0	1.0	0.1
10,12	0.6	2.2	1.5	1.5	0.1	1.0	1.5	0.1
16,18	0.8	5.0	2.0	2.5	0.3	1.5	2.0	0.2
20	0.9	6.2	2.0	3.5	0.4	1.5	3.0	0.3
24	1.1	8.9	3.0	3.5	0.5	1.5	3.0	0.3
30	1.4	10.4	3.0	3.5	0.6	2.0	3.5	0.4
36	1.7	15.0	3.5	4.5	0.9	2.0	4.0	0.5
42	1.9	20.4	4.5	5.0	1.5	2.5	5.0	0.8
48	2.2	26.6	4.5	6.0	2.0	2.5	6.0	1.1
54	2.5	33.7	6.0	6.0	3.0	3.0	6.0	1.4
60	2.7	41.6	6.0	7.0	3.8	3.0	7.0	1.8
66	3.0	50.3	6.5	8.0	5.1	3.5	8.0	2.7
72	3.3	59.9	7.5	8.0	6.3	4.0	8.0	3.3
78	3.6	70.2	8.0	9.0	8.1	4.0	9.0	3.9
84	3.8	81.5	8.5	10.0	10.3	4.5	10.0	5.3
90	4.1	93.5	9.5	10.0	12.2	5.0	10.0	6.3
96	4.4	106.4	10.0	11.0	15.0	5.0	11.0	7.4

I.D. (IN.)	$\Delta = 22.50^\circ$							
	G (FT.)	THRUST (TONS)	EARTH			ROCK		
			A (FT.)	B (FT.)	VOL. (C.Y.)	A (FT.)	B (FT.)	VOL. (C.Y.)
4,6,8	0.8	2.0	1.5	1.5	0.1	1.0	1.0	0.1
10,12	1.1	4.4	2.0	2.5	0.3	1.5	1.5	0.1
16,18	1.6	9.9	3.0	3.5	0.6	2.0	2.5	0.3
20	1.8	12.3	3.5	3.5	0.7	2.0	3.0	0.4
24	2.2	17.7	4.0	4.5	1.0	3.0	3.5	0.5
30	2.7	20.7	5.0	4.5	1.5	3.0	4.0	0.8
36	3.3	29.8	5.5	5.5	2.3	4.0	4.0	1.3
42	3.8	40.5	7.0	6.0	3.9	4.5	5.0	2.1
48	4.4	52.9	8.0	7.0	5.7	4.5	6.0	2.8
54	4.9	67.0	9.0	8.0	8.0	6.0	6.0	4.1
60	5.5	82.7	9.5	9.0	10.6	6.0	7.0	5.3
66	6.0	100.1	10.5	10.0	14.1	6.5	8.0	7.2
72	6.6	119.1	11.0	11.0	17.6	7.5	8.0	9.1
78	7.1	139.8	12.0	12.0	22.5	8.0	9.0	11.7
84	7.6	162.1	13.0	12.5	27.2	8.5	10.0	14.8
90	8.2	186.1	14.0	13.5	33.7	9.5	10.0	17.7
96	8.7	211.7	15.0	14.5	41.2	10.0	11.0	21.8



**STANDARD CONSTRUCTION DETAIL  
HORIZONTAL THRUST BLOCK AT PIPE BEND  
SHEET 2 OF 3**

SCALE: N.T.S.

REVISED:  
JANUARY 2022

W02

I.D. (IN.)	$\Delta = 30^\circ$									I.D. (IN.)	$\Delta = 45^\circ$								
	G (FT.)	THRUST (TONS)	EARTH			ROCK			G (FT.)		THRUST (TONS)	EARTH			ROCK				
			A (FT.)	B (FT.)	VOL. (C.Y.)	A (FT.)	B (FT.)	VOL. (C.Y.)				A (FT.)	B (FT.)	VOL. (C.Y.)	A (FT.)	B (FT.)	VOL. (C.Y.)		
4,6,8	1.0	2.6	2.0	1.5	0.2	1.0	1.5	0.1	4,6,8	1.5	3.9	2.0	2.0	0.2	1.5	1.5	0.1		
10,12	1.5	5.9	2.5	2.5	0.3	2.0	1.5	0.2	10,12	2.2	8.7	3.5	2.5	0.5	2.0	2.5	0.3		
16,18	2.2	13.2	3.5	4.0	0.8	2.5	3.0	0.4	16,18	3.2	19.5	4.5	4.5	1.2	3.0	3.5	0.6		
20	2.4	16.3	4.5	4.0	1.0	3.0	3.0	0.5	20	3.6	24.1	5.5	4.5	1.5	3.5	3.5	0.7		
24	2.9	23.4	6.0	4.0	1.4	3.5	3.5	0.7	24	4.3	34.6	8.0	4.5	2.3	4.5	4.0	1.1		
30	3.6	27.5	6.5	5.0	1.9	3.5	4.0	0.9	30	5.4	40.6	8.5	5.0	3.2	5.5	4.0	1.6		
36	4.4	39.5	7.0	6.0	3.4	4.5	4.5	1.6	36	6.5	58.5	10.0	6.0	5.3	6.5	4.5	2.6		
42	5.1	53.8	8.0	7.0	5.1	5.5	5.0	2.5	42	7.5	79.6	11.5	7.0	8.1	8.0	5.0	4.2		
48	5.8	70.3	9.0	8.0	7.4	6.0	6.0	3.7	48	8.6	104.0	13.0	8.0	11.9	9.0	6.0	6.3		
54	6.5	89.0	10.0	9.0	10.3	7.0	6.5	5.3	54	9.7	131.5	15.0	9.0	17.1	10.5	6.5	8.9		
60	7.3	110.0	11.0	10.0	13.9	7.5	7.5	7.3	60	10.7	162.4	16.5	10.0	23.1	11.0	7.5	12.0		
66	8.0	132.9	12.5	11.0	18.9	8.5	8.0	9.6	66	11.8	196.5	18.0	11.0	30.1	12.0	8.5	16.2		
72	8.7	158.6	13.5	12.0	24.0	9.0	9.0	12.3	72	12.9	233.9	19.5	12.0	38.6	14.0	8.5	20.7		
78	9.4	185.6	14.5	13.0	30.0	10.0	9.5	15.6	78	13.9	274.5	21.5	13.0	49.8	14.5	9.5	25.9		
84	10.1	215.3	15.5	14.0	37.1	10.5	10.5	19.5	84	15.0	318.4	23.0	14.0	61.2	15.5	10.5	32.6		
90	10.9	247.1	16.5	15.0	45.0	11.5	11.0	23.9	90	16.1	365.5	24.5	15.0	74.5	17.5	10.5	39.6		
96	11.6	281.2	18.0	16.0	55.5	12.5	11.5	28.9	96	17.1	415.6	26.0	16.0	89.5	18.5	11.5	48.5		

I.D. (IN.)	$\Delta = 67.50^\circ$									I.D. (IN.)	$\Delta = 90^\circ$								
	G (FT.)	THRUST (TONS)	EARTH			ROCK			G (FT.)		THRUST (TONS)	EARTH			ROCK				
			A (FT.)	B (FT.)	VOL. (C.Y.)	A (FT.)	B (FT.)	VOL. (C.Y.)				A (FT.)	B (FT.)	VOL. (C.Y.)	A (FT.)	B (FT.)	VOL. (C.Y.)		
4,6,8	2.1	5.6	3.0	2.0	0.3	2.0	1.5	0.2	4,6,8	2.7	7.1	5.0	1.5	0.4	2.0	2.0	0.2		
10,12	3.1	12.6	5.5	2.5	0.8	3.5	2.0	0.4	10,12	4.0	16.0	6.5	2.5	1.0	3.5	2.5	0.5		
16,18	4.7	28.3	7.5	4.0	1.9	5.5	3.0	0.9	16,18	6.0	36.0	9.0	4.0	2.4	4.5	4.0	1.0		
20	5.2	34.9	9.0	4.0	2.3	5.5	3.5	1.2	20	6.6	44.4	10.0	4.5	3.1	6.0	4.0	1.5		
24	6.2	50.3	11.5	4.5	3.5	6.5	4.0	1.6	24	7.9	64.0	14.5	4.5	5.0	8.0	4.0	2.1		
30	7.8	58.9	12.0	5.0	4.8	7.5	4.0	2.2	30	9.9	75.0	15.0	5.0	6.7	10.0	4.0	3.3		
36	9.4	84.9	14.5	6.0	8.2	9.5	4.5	3.8	36	11.9	108.0	18.0	6.0	11.4	12.0	4.5	5.3		
42	10.9	115.5	17.0	7.0	12.8	11.0	5.5	6.3	42	13.9	147.0	21.0	7.0	17.8	14.0	5.5	8.7		
48	12.5	150.9	19.0	8.0	18.4	13.0	6.0	9.2	48	15.9	192.0	24.0	8.0	26.2	16.0	6.0	12.4		
54	14.0	191.0	21.5	9.0	26.0	15.0	6.5	12.9	54	17.9	243.0	27.00	9.0	36.9	18.0	7.0	18.1		
60	15.6	235.8	24.0	10.0	35.6	16.0	7.5	17.6	60	19.9	299.8	30.0	10.0	50.3	20.0	7.5	24.0		
66	17.1	285.3	26.0	11.0	46.0	18.0	8.0	23.0	66	21.8	362.8	33.0	11.0	66.2	22.0	8.5	32.5		
72	18.7	339.5	28.5	12.0	57.8	19.0	9.0	28.4	72	23.8	431.8	36.0	12.0	85.6	24.0	9.0	41.0		
78	20.2	398.5	31.0	13.0	75.7	21.0	9.5	37.4	78	25.7	506.7	39.0	13.0	108.2	26.0	10.0	53.2		
84	21.8	462.1	33.5	14.0	94.7	22.0	10.5	46.5	84	27.7	587.7	42.0	14.0	134.4	28.0	10.5	64.8		
90	23.3	530.5	35.5	15.0	114.4	24.5	11.0	58.2	90	29.0	674.6	45.0	15.0	164.9	30.0	11.5	81.2		
96	24.9	603.6	38.0	16.0	138.9	25.5	12.0	70.0	96	31.6	767.5	48.0	16.0	199.0	32.0	12.0	95.1		



**STANDARD CONSTRUCTION DETAIL  
HORIZONTAL THRUST BLOCK AT PIPE BEND  
SHEET 3 OF 3**

SCALE: N.T.S.

REVISED:  
JANUARY 2022

W03

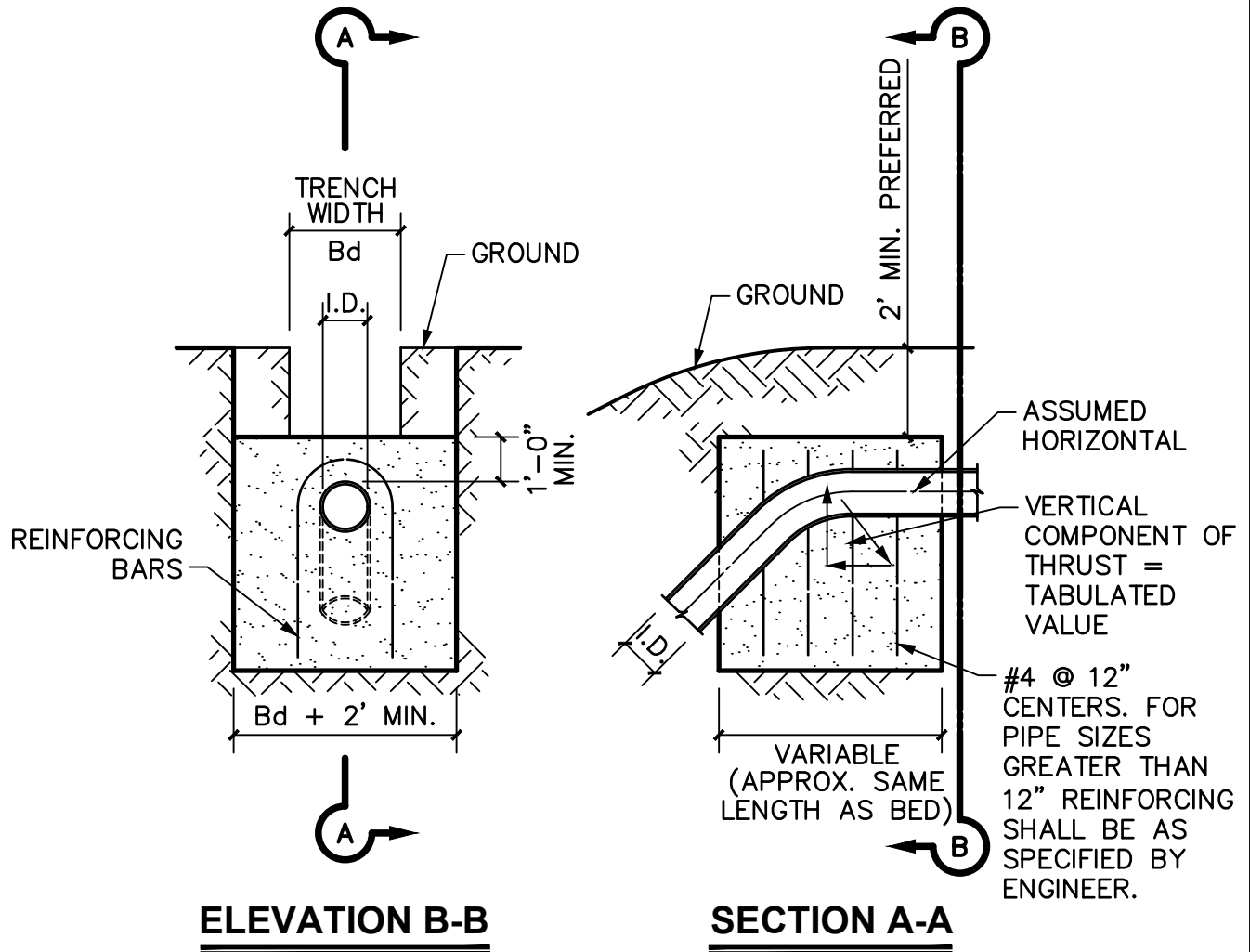

Δ	11.25°		22.50°		30°		45°		67.50°		90°		Δ
I.D. (IN.)	THRUST (TONS)	VOL. (C.Y.)	THRUST (TONS)	VOL. (C.Y.)	THRUST (TONS)	VOL. (C.Y.)	THRUST (TONS)	VOL. (C.Y.)	THRUST (TONS)	VOL. (C.Y.)	THRUST (TONS)	VOL. (C.Y.)	I.D. (IN.)
4,6,8	1.0	0.5	2.0	1.0	2.5	1.3	3.6	1.8	4.6	2.3	5.0	2.5	4,6,8
10,12	2.2	1.1	4.3	2.2	5.7	2.8	8.0	4.0	10.5	5.2	11.3	5.7	10,12
16,18	5.0	2.5	9.7	4.9	12.7	6.4	18.0	9.0	23.5	11.8	25.5	12.7	16,18
20	6.1	3.1	12.0	6.0	15.7	7.9	22.2	11.1	29.2	14.5	31.4	15.7	20
24	8.2	4.4	17.3	8.7	22.6	11.3	32.0	16.0	41.8	20.9	45.2	22.6	24
30	10.5	5.2	20.3	10.1	26.5	13.3	37.5	18.8	49.0	24.5	53.1	26.5	30
36	14.9	7.5	29.2	14.6	38.2	19.1	54.0	27.0	70.5	35.3	76.4	38.2	36
42	20.3	10.1	39.8	19.9	52.0	26.0	73.5	36.7	96.0	48.0	104.0	52.0	42
48	26.5	13.2	51.9	26.0	67.9	33.9	96.0	48.0	126.0	62.7	136.0	67.9	48
54	33.5	16.8	65.7	32.9	85.9	42.9	122.0	60.7	159.0	79.4	172.0	85.9	54
60	41.4	20.7	81.2	40.6	106.0	53.0	150.0	75.0	196.0	98.0	212.0	106.0	60
66	50.1	25.0	98.2	49.1	128.0	64.2	182.0	90.7	237.0	119.0	257.0	128.0	66
72	59.6	29.8	117.0	58.4	153.0	76.3	216.0	108.0	282.0	141.0	305.0	153.0	72
78	69.9	35.0	137.0	68.6	179.0	90.0	254.0	127.0	331.0	166.0	358.0	179.0	78
84	81.1	40.5	159.0	79.5	208.0	104.0	294.0	147.0	384.0	192.0	416.0	208.0	84
90	93.1	46.5	183.0	91.3	239.0	119.0	337.0	169.0	441.0	221.0	477.0	239.0	90
96	106.0	53.0	208.0	104.0	272.0	136.0	384.0	192.0	502.0	251.0	543.0	272.0	96

**NOTE:**

1. REFER TO STANDARD DETAIL W05 FOR GENERAL NOTES.



**STANDARD CONSTRUCTION DETAIL**  
**VERTICAL THRUST BLOCK AT PIPE BEND**

SCALE: 1/4"=1'-0"

REVISED:  
 JANUARY 2022

W04

**GENERAL NOTES FOR ALL THRUST BLOCKS:**

1. CONCRETE FOR BLOCKING SHALL BE CLASS B CONCRETE PER TXDOT ITEM 421.
2. ALL CALCULATIONS ARE BASED ON INTERNAL PRESSURE OF 200 PSI FOR DUCTILE IRON, P.V.C.
3. VOLUMES OF THRUST BLOCKS ARE NET VOLUMES OF CONCRETE TO BE FURNISHED. THE CORRESPONDING WEIGHT OF THE CONCRETE (CLASS B) IS EQUAL TO OR GREATER THAN THE VERTICAL COMPONENT OF THE THRUST ON THE VERTICAL BEND.
4. WALL THICKNESS (T) ASSUMED HERE FOR ESTIMATING PURPOSES ONLY.
5. POUR CONCRETE FOR BLOCK AGAINST UNDISTURBED EARTH.
6. DIMENSIONS MAY BE VARIED AS REQUIRED BY FIELD CONDITIONS WHERE AND AS DIRECTED BY THE ENGINEER. THE VOLUME OF CONCRETE BLOCKING SHALL BE LESS THAN SHOWN HERE.
7. THE SOIL BEARING PRESSURES ARE BASED ON 1000 LBS./S.F. IN SOIL AND 2000 LBS./S.F. IN ROCK.
8. USE POLYETHYLENE WRAP OR EQUAL BETWEEN CONCRETE AND BEND, TEE, OR PLUG TO PREVENT THE CONCRETE FROM STICKING TO IT.
9. FOR STANDARD FITTINGS, CONCRETE SHALL NOT EXTEND BEYOND JOINTS.



**STANDARD CONSTRUCTION DETAIL  
THRUST BLOCK  
GENERAL NOTES**

SCALE: N.T.S.

REVISED:  
JANUARY 2022

W05

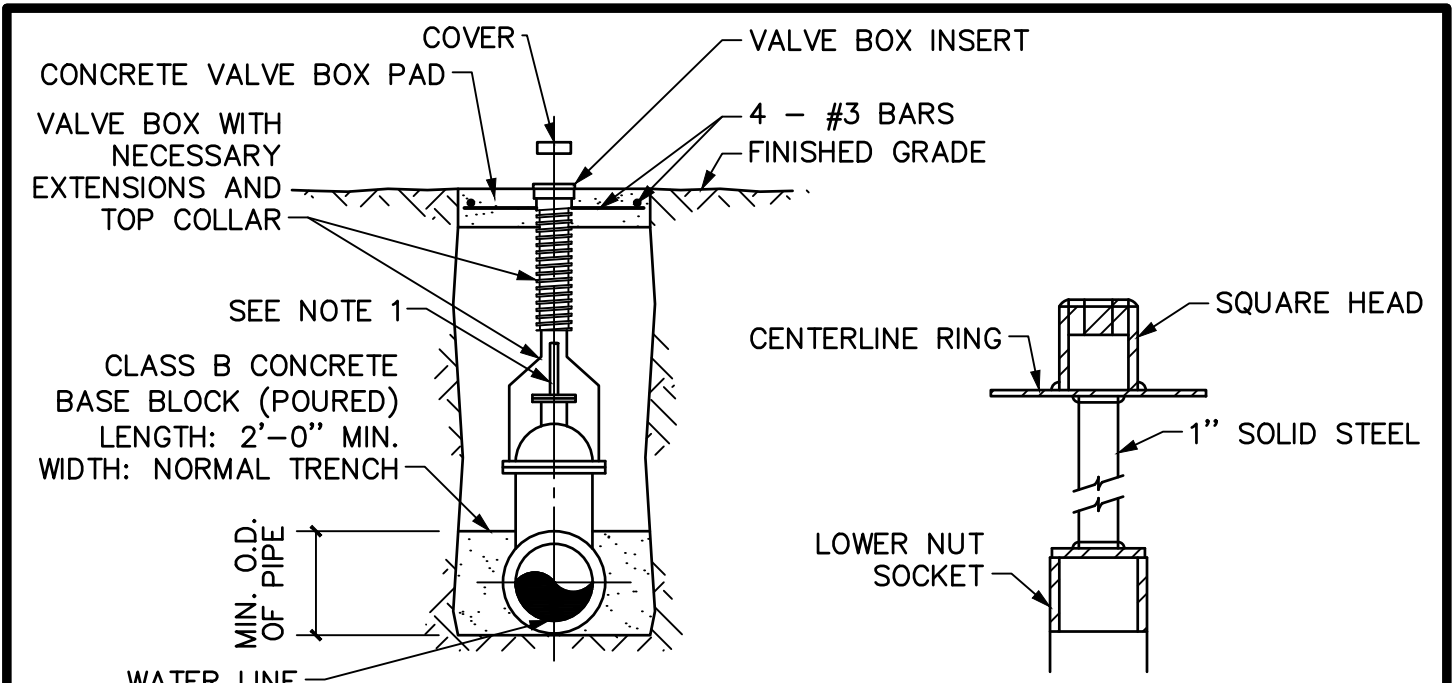

**VALVE SETTING & BOX**

**VALVE EXTENSION**

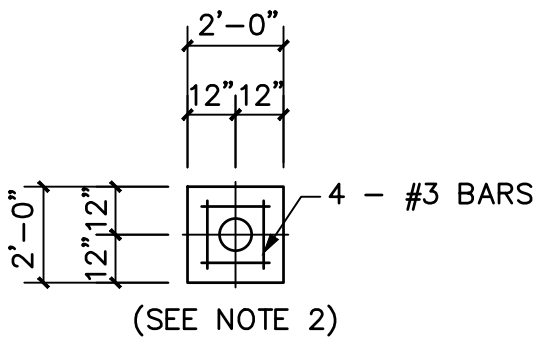

**VALVE BOX PAD PLAN**

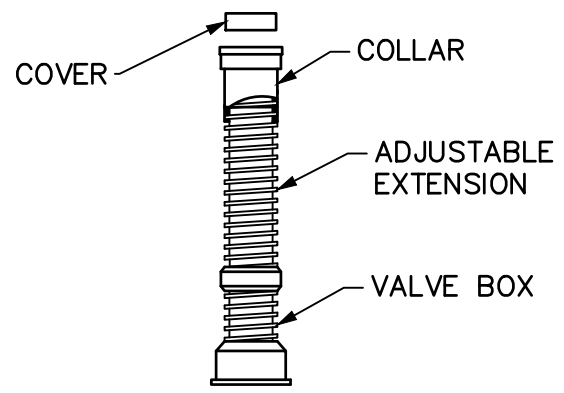

**VALVE BOX WITH EXTENSION**

**NOTES:**

1. A VALVE EXTENSION STEM SHALL BE REQUIRED FOR ANY VALVE WHOSE OPERATING NUT IS LOCATED IN EXCESS OF 4' BELOW THE TOP OF VALVE BOX. THIS EXTENSION SHALL BE OF SUFFICIENT LENGTH TO INSURE THAT ITS TOP IS WITHIN 12" OF THE VALVE BOX COVER.
2. CONCRETE PAD 24" SQUARE SHALL BE POURED AROUND ALL VALVE BOXES NOT PLACED WITHIN CONCRETE PAVEMENT. CLASS A CONCRETE, 6" THICK WITH AN EPOXY COATING.
3. VALVES SHALL BE AFC MUELLER VALVES (OR APPROVED EQUAL) WITH STAINLESS STEEL HARDWARE (NUTS AND BOLTS). FLANGED WHERE APPLICABLE. MATERIALS AND INSTALLATION SHALL BE IN ACCORDANCE WITH CITY OF HOUSTON STANDARD SPECIFICATION 02085.
4. REFER TO TXDOT ITEM 421 FOR CLASS B CONCRETE REQUIREMENTS.

	<p><b>STANDARD CONSTRUCTION DETAIL</b></p> <p><b>GATE VALVE</b></p>	<p>SCALE: 1/4"=1'-0"</p> <p>REVISED: JANUARY 2022</p> <p>W06</p>
---	---	--

INCLUDING THE CITY OF DAYTON STANDARD CONSTRUCTION DETAIL IN PLANS DOES NOT RELIEVE THE SEALING ENGINEER OF THE RESPONSIBILITY FOR THE SPECIFIC DESIGN. THESE DETAILS SHOULD BE CONSIDERED MINIMUM STANDARDS WHICH THE SEALING ENGINEER MAY MODIFY TO MEET SITE SPECIFIC DESIGN REQUIREMENTS.

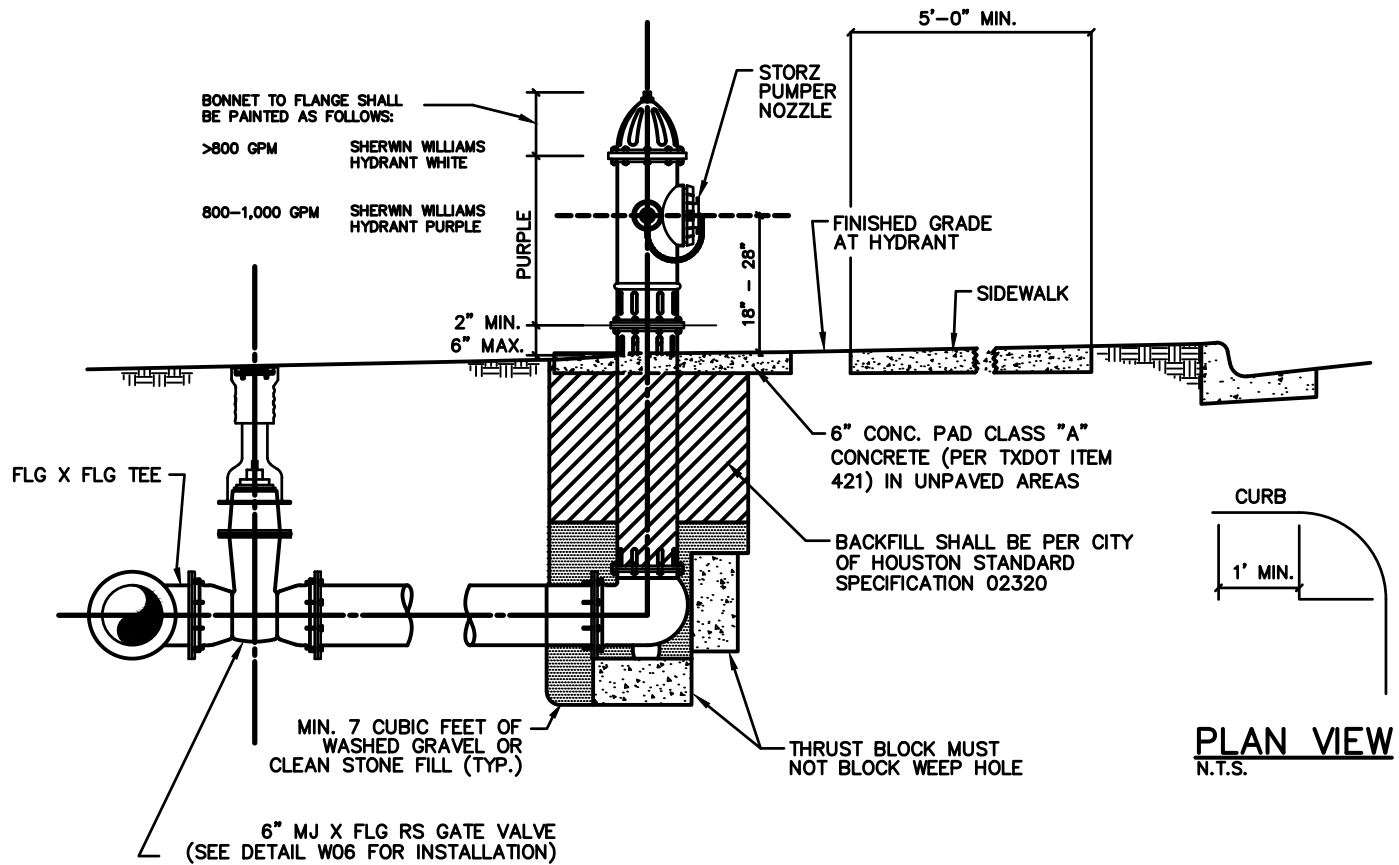

**NOTES:**

1. ALL FIRE HYDRANTS SHALL CONFORM TO AWWA STANDARD SPECIFICATIONS FOR FIRE HYDRANTS, C502. FIRE HYDRANTS SHALL HAVE A 5 1/4" MIN VALVE OPENING AND AN INSIDE BARREL DIAMETER OF APPROXIMATELY 7". ALL HYDRANTS SHALL BE EQUIPPED WITH A BREAKAWAY FLANGE.
2. ACTUAL VALVE LOCATION WILL DEPEND ON LOCATION OF WATER MAIN.
3. FIRE HYDRANT LEADS GREATER THAN 2 FEET REQUIRE JOINT THRUST RETAINERS.
4. FIRE HYDRANT NO CLOSER THAN 18" TO EXISTING OR PROPOSED SIDEWALKS. (TYPICAL)
5. TOP OF PIPE SHALL BE A MINIMUM 48" BELOW GRADE.
6. FIRE HYDRANT SHALL BE PLACED ON THE EXTENDED LOT LINE WHEN POSSIBLE.
7. FIRE HYDRANT SHALL BE LOCATED A MINIMUM 1 FT. OUTSIDE OF THE AREA BETWEEN THE P.C.'S OF THE CORNER TURNING RADIUS AT THE INTERSECTIONS. (SEE PLAN VIEW)
8. ALL FIRE HYDRANTS SHALL BE AT LEAST 42 INCHES FROM ANY ABOVE GROUND OBSTRUCTIONS, SUCH AS GUARDRAILS, RETAINING WALLS, BOLLARDS, ETC.
9. ALL BELOW GROUND IRON ASSEMBLES SHALL BE WRAPPED IN POLYETHYLENE ACCORDING TO AWWA C105.
10. ACCEPTABLE MANUFACTURERS: SEE DAYTON DESIGN STANDARDS-PART 9:STANDARD PRODUCTS LIST.
11. GRADELOCK OR APPROVED EQUAL CONNECTOR PIPE SHALL BE USED AS NECESSARY TO ENSURE THE FIRE HYDRANT IS SET AT THE PROPER GRADE.
12. A BLUE REFLECTORIZED PAVEMENT MARKER ON THE CENTERLINE OF THE STREET IS REQUIRED TO MARK THE LOCATION OF THE FIRE HYDRANT.
13. FIRE HYDRANTS SHALL BE PAINTED ACCORDING TO NOTES ABOVE.
14. ALL JOINTS SHALL BE MECHANICAL JOINTS UNLESS OTHERWISE SPECIFIED.
15. RESTRAINED JOINTS ON MJ FITTINGS/FLANGED WHERE POSSIBLE. SEE DAYTON DESIGN STANDARDS-PART 9:STANDARD PRODUCTS LIST.
16. MATERIALS AND INSTALLATION SHALL BE IN ACCORDANCE WITH CITY OF HOUSTON STANDARD SPECIFICATION 02520.
17. PLACE SPLASH PADS AROUND FIRE HYDRANT BARREL FOR BREAKAWAY TO FUNCTION PROPERLY AND PREVENT DAMAGE TO THE UNDERGROUND CONNECTION. SPLASH PAD SHALL BE 3' WIDE AND EXTEND TO CURB.



**STANDARD CONSTRUCTION DETAIL**

**FIRE HYDRANT**

SCALE: 1/2"=1'-0"

REVISED:  
JANUARY 2022

W07

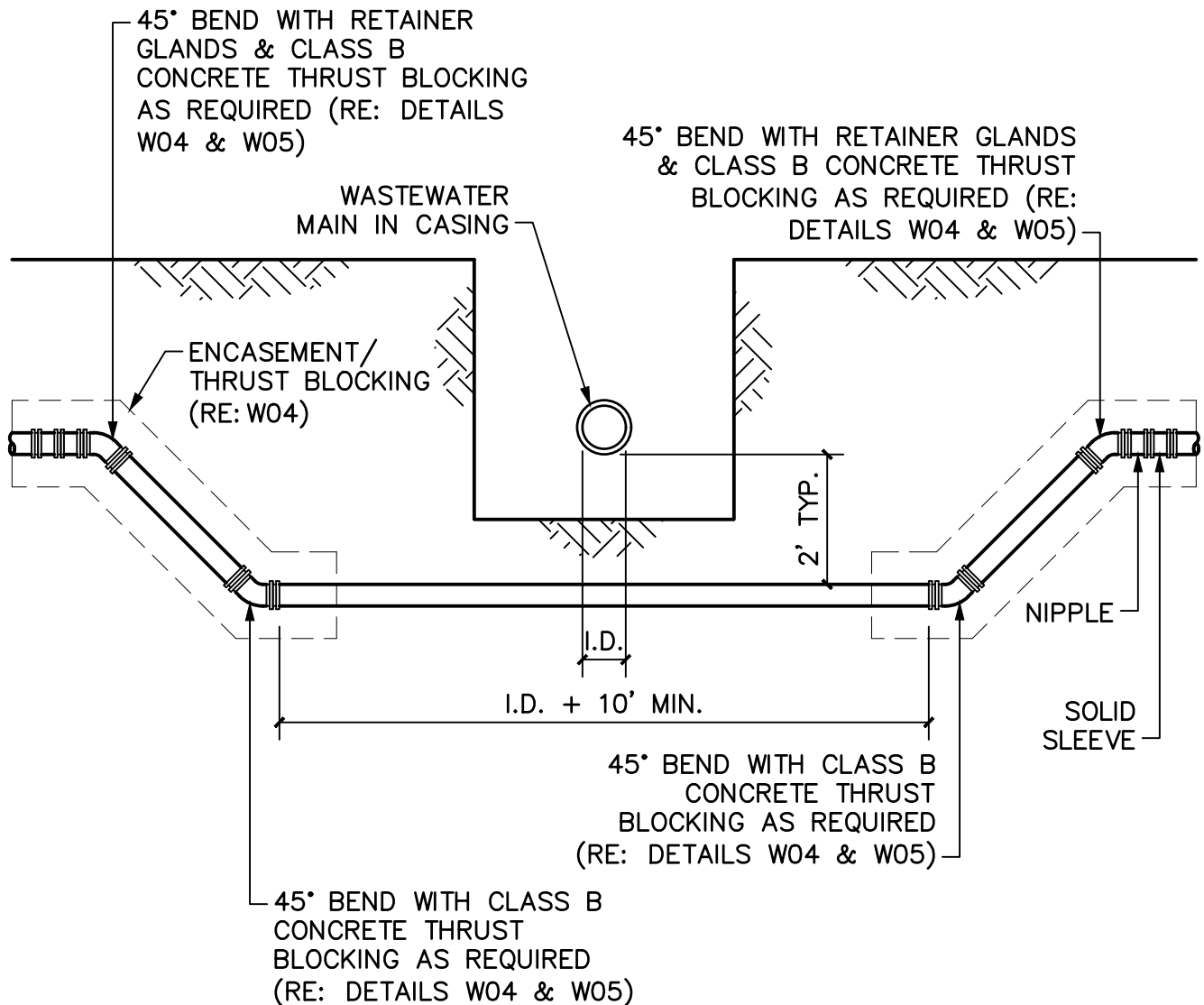

**NOTES:**

1. INSTALLING PIPE WITH CLEARANCES OF LESS THAN 2' BETWEEN WATER AND SEWER SHALL BE APPROVED BY THE CITY.
2. INSTALLATION AND DESIGN SHALL BE PER TCEQ CHAPTER 217.
3. 3M MARKER PADS SHALL BE LOCATED AT ALL FITTINGS.
4. REFER TO TXDOT ITEM 421 FOR CLASS B CONCRETE REQUIREMENTS.



**STANDARD CONSTRUCTION DETAIL  
WATER MAIN LOWERING  
BELOW WASTEWATER MAIN**

SCALE: 3/8"=1'-0"

REVISED:  
JANUARY 2022

W08



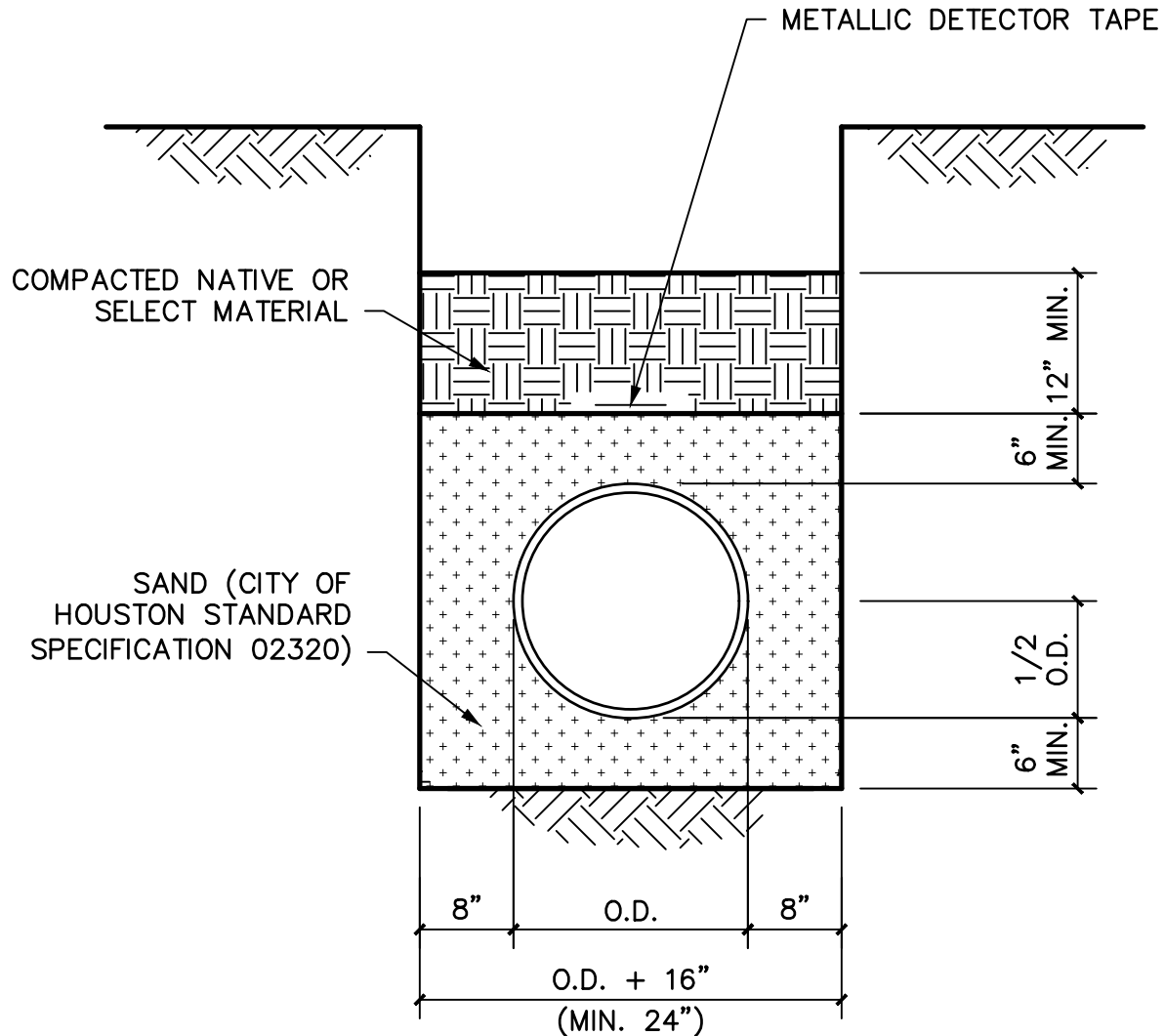

**SAND**

**NOTES:**

1. UTILIZE SAND EMBEDMENT FOR PVC WATER LINE INSTALLATIONS.
2. INSTALLATION SHALL BE IN ACCORDANCE WITH CITY OF HOUSTON STANDARD SPECIFICATION 02320.
3. BEDDING DEPTH MEASURED FROM OUTSIDE THE PIPE BELL.
4. COMPRESSED LOW STRENGTH MATERIAL (OR CEMENT STABILIZED SAND) IS NOT ACCEPTABLE.



**STANDARD CONSTRUCTION DETAIL**

**EMBEDMENT "B-4" (WATER)**

SCALE: 3/4"=1'-0"

REVISED:  
JANUARY 2022

W09

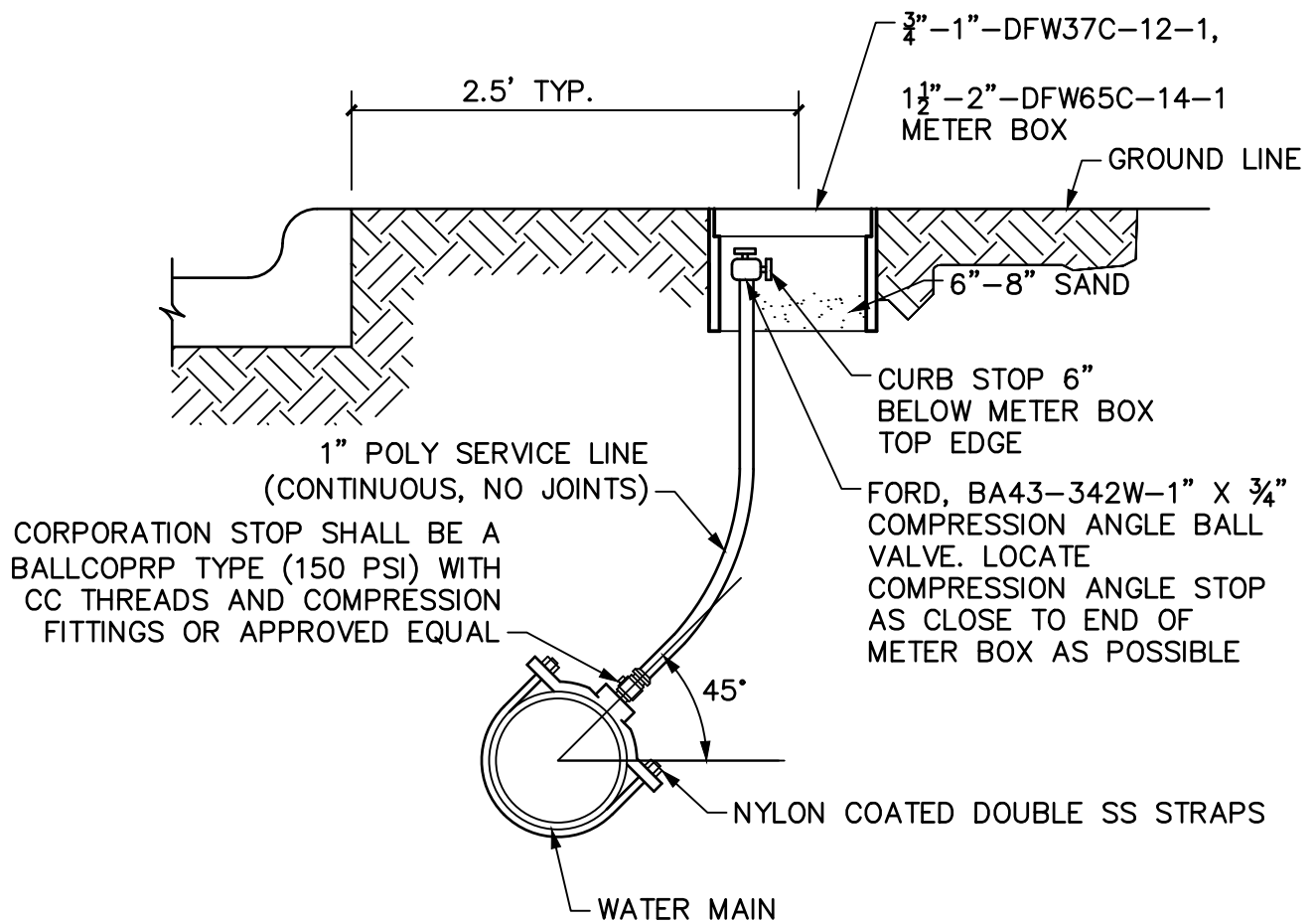

**NOTES:**

1. WATER SERVICES SHALL NOT BE CONNECTED TO FIRE HYDRANT LINES OR TO FIRE SERVICE MAINS.
2. METER BOX SHALL BE LOCATED OUT OF ALL FLATWORK, SIDEWALKS AND APPROACHES.
3. SERVICES SHALL BE IN SAND 6" ABOVE AND BELOW THE PIPE.
4. MATERIALS AND INSTALLATION SHALL BE IN ACCORDANCE WITH CITY OF HOUSTON STANDARD SPECIFICATION 02512.
5. SAND SHALL BE PLACED 12" ON BOTH SIDES OF SERVICE SADDLE
6. SLEEVE POLY SERVICE SHALL BE PLACED INSIDE 2" SCH 40 PVC ON LONG SIDE SERVICES.
7. PROVIDE SMITH BLAIR SADDLES (AND TAPPING SLEEVE AND VALVE).



**STANDARD CONSTRUCTION DETAIL**  
**TYPICAL SERVICE CONNECTION**

SCALE: 3/4"=1'-0"

REVISED:  
JANUARY 2022

W10

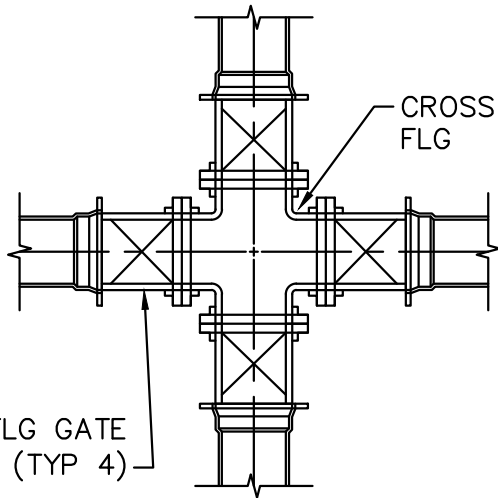

NOTE: ALL CROSSES SHALL HAVE 4 FLANGED GATE VALVES

CROSS FITTINGS

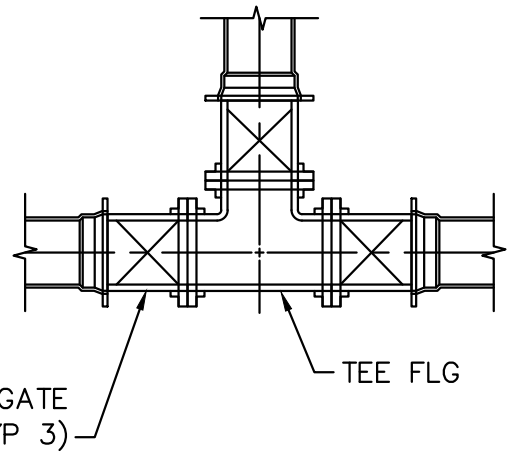

NOTE: ALL TEES SHALL HAVE 3 FLANGED GATE VALVES

TEE FITTINGS

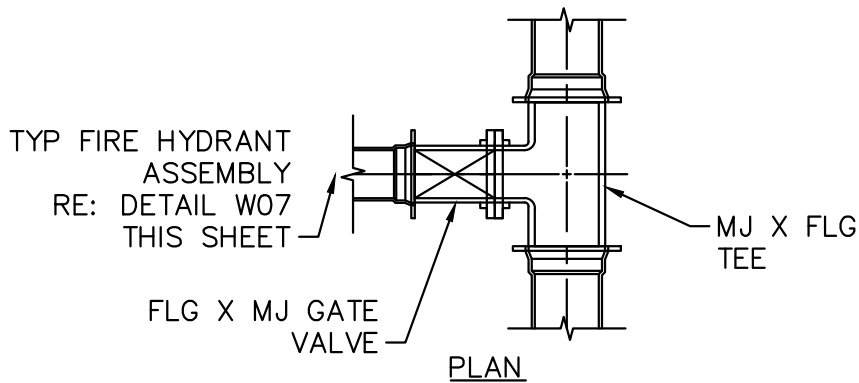
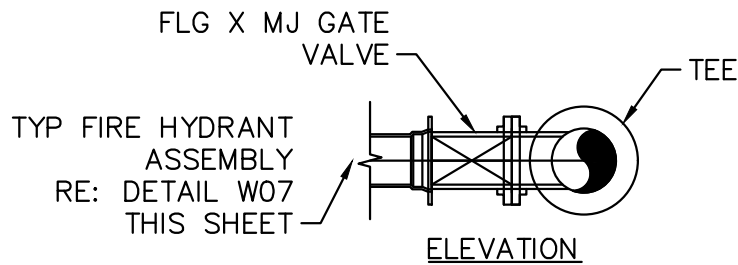

FIRE HYDRANT FITTINGS

NOTES:

1. ALL CROSSES, TEES, VALVES AND FIRE HYDRANTS SHALL HAVE FLANGED CONNECTIONS.
2. REFER TO BLOCKING DETAILS FOR BLOCK DESIGN AND INSTALLATION.
3. MEGA-LUG ON ALL MJ FITTINGS.



**STANDARD CONSTRUCTION DETAIL**

**FITTINGS (WATER)**

SCALE: 1/2"=1'-0"

REVISED:  
JANUARY 2022

W11

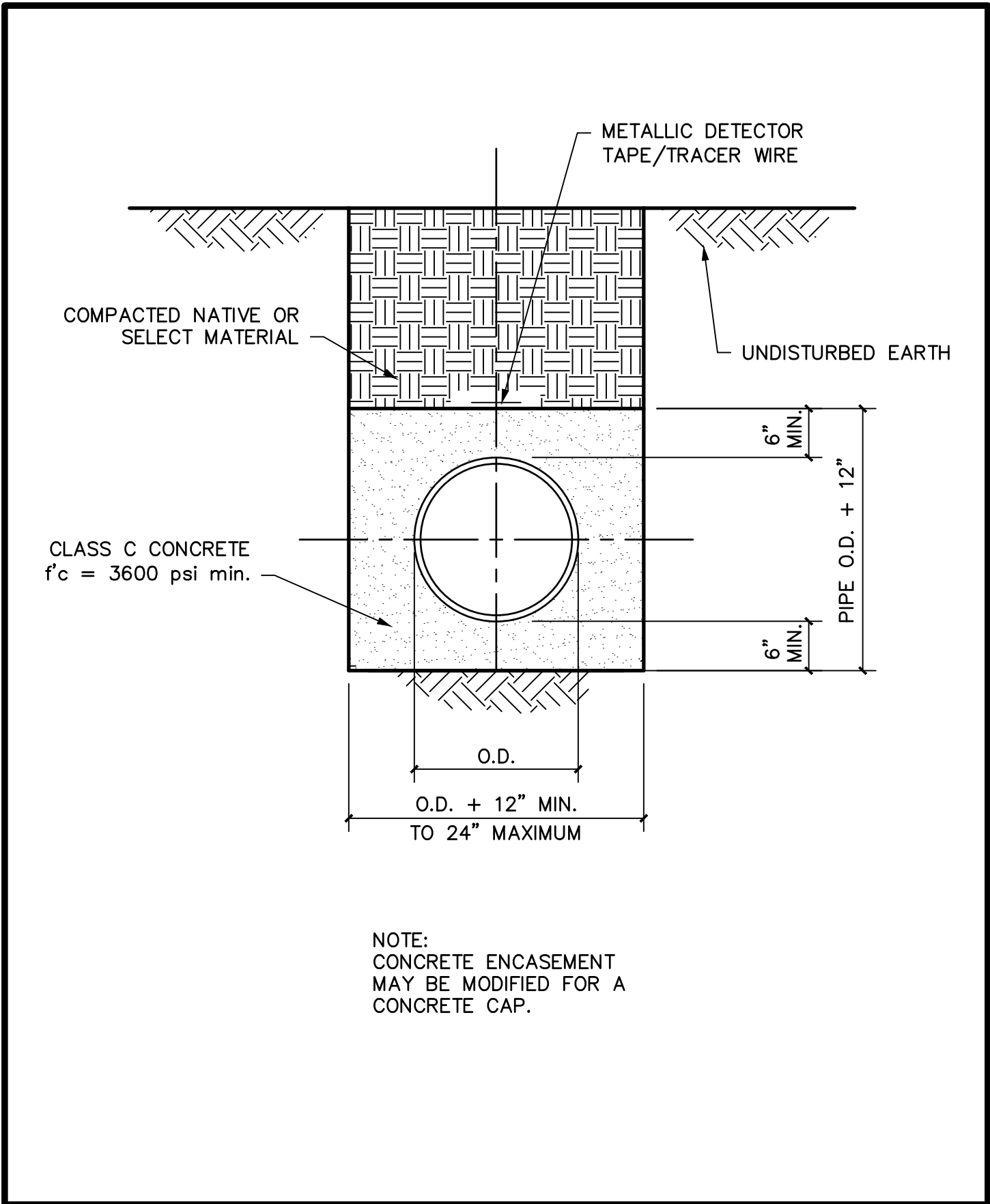

STANDARD CONSTRUCTION DETAIL

CONCRETE ENCASEMENT

SCALE: 3/4"=1'-0"

REVISED:  
 JANUARY 2022

W12

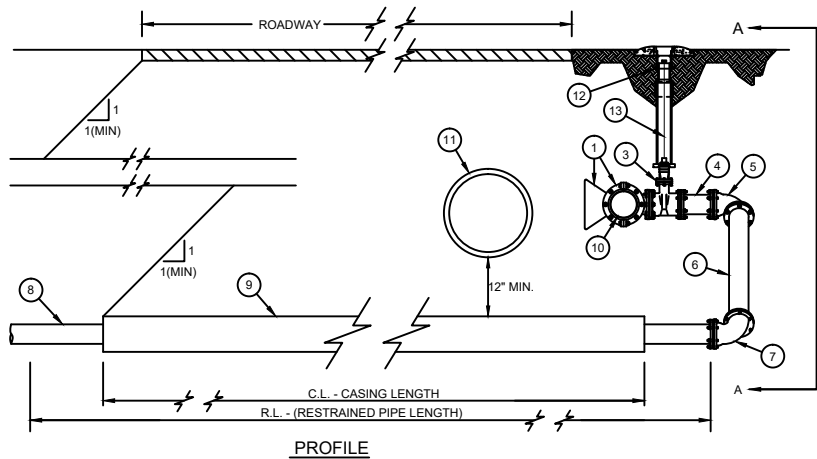

- NO. DESCRIPTION**
1. TAPPING SLEEVE WITH CONCRETE THRUST BLOCKING (REQUIRED). SEE SPECIFICATIONS FOR APPROVED MODELS. SIZE ON SIZE TAPPING SLEEVES SHALL BE MECHANICAL JOINT FULL BODY DUCTILE / CAST IRON ONLY.
  2. WRAP TAPPING SLEEVE WITH 2 LAYERS HDPE PLASTIC FILM (HDCLPE PER AWWA C-105) - 4 MILS. EACH LAYER - EXTEND HDPE 3 FT. EACH WAY FROM FITTINGS - DUCT TAPE ENDS.
  3. TAPPING VALVE - FLANGE x R.M.J.
  4. D.I.P. SHORT L  $\geq 18"$
  5. R.M.J. DUCTILE IRON 90° BEND - ROTATE DOWN, AS APPROVED
  6. DUCTILE IRON PIPE - RESTRAINED
  7. R.M.J. DUCTILE IRON 90° BEND - ROTATE UP, AS APPROVED, CONCRETE THRUST BLOCKING MAY ALSO BE REQUIRED. SEE NOTE IN CHART A BELOW
  8. DUCTILE IRON PIPE - RESTRAINED - SEE CHART A
  9. STEEL CASING - SEE CHART B
  10. EXISTING WATER MAIN EXISTING INFRASTRUCTURE THAT PREVENTS FRONT SIDE TAP - BACKSIDE TAP WILL BE PERMITTED ONLY WHERE EXISTING INFRASTRUCTURES PREVENTS FRONT SIDE TAP, AND REQUIRES APPROVAL OF THE CITY ENGINEER.
  11. STANDARD VALVE BOX ASSEMBLY
  12. VALVE EXTENSION (WHEN OPERATING NUT IS GREATER THAN 4.5 FEET DEEP)

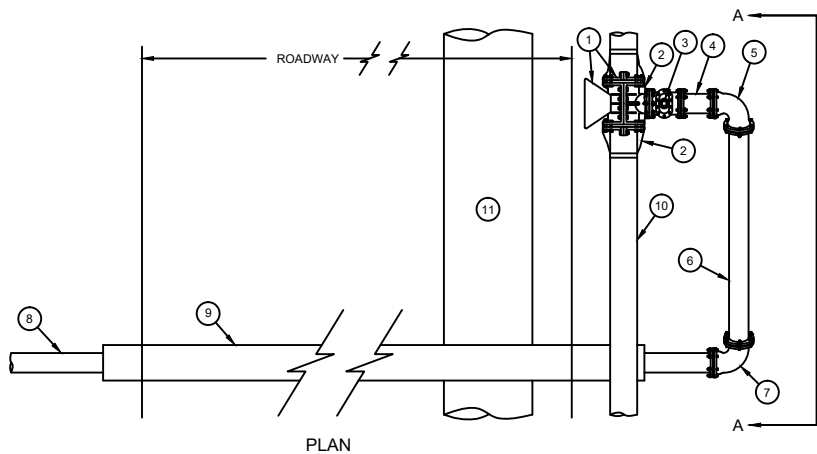

**CHART A - RESTRAINED LENGTH REQUIREMENTS**

PIPE DIA. (INCHES)	TOTAL RESTRAINED LENGTH - R.L. - (FT)
3"	64' + CASING LENGTH (C.L)
4"	77' + CASING LENGTH (C.L)
6"	109' + CASING LENGTH (C.L)
8"	140' + CASING LENGTH (C.L)
10"	169' + CASING LENGTH (C.L)
12"	196' + CASING LENGTH (C.L)
16"	249' + CASING LENGTH (C.L)

CONCRETE THRUST BLOCK (WRAP BEND PER 1) REQUIRED AT BOTTOM BEND 2 IF REQUIRED RESTRAINED LENGTH (R.L.) CAN NOT BE COMPLETELY INSTALLED.

**CHART B - ROADWAY CASING REQUIREMENTS**

PIPE DIA. (INCHES)	CASING MIN. DIAMETER (INCHES)	CASING WALL THICKNESS - MIN. (INCHES)
3"	8"	0.250"
4"	8"	0.250"
6"	12.75"	0.250"
8"	16"	0.250"
10"	18"	0.250"
12"	20"	0.250"
16"	24"	0.250"

LARGER DIAMETER CASING MAY BE REQUIRED DUE TO LENGTH OF CROSSINGS AND RESTRAINED JOINT DIMENSIONS. SEE PLANS AND SPECIFICATIONS.

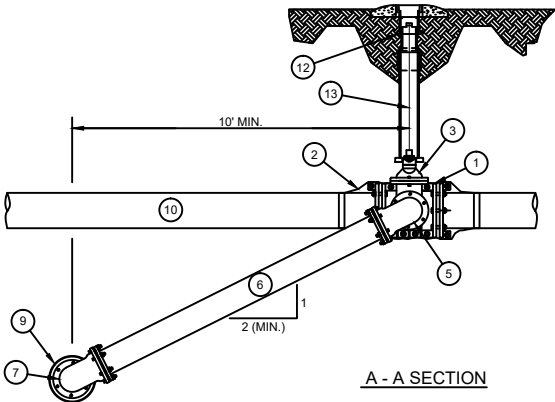

**STANDARD CONSTRUCTION DETAIL  
BACK SIDE TAP  
16" AND SMALLER MAINS**

SCALE: NTS  
REVISED:  
JANUARY 2022  
W13

INCLUDING THE CITY OF DAYTON STANDARD CONSTRUCTION DETAIL IN PLANS DOES NOT RELIEVE THE SEALING ENGINEER OF THE RESPONSIBILITY FOR THE SPECIFIC DESIGN. THESE DETAILS SHOULD BE CONSIDERED MINIMUM STANDARDS WHICH THE SEALING ENGINEER MAY MODIFY TO MEET SITE SPECIFIC DESIGN REQUIREMENTS.

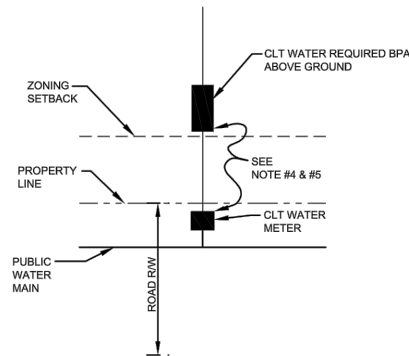
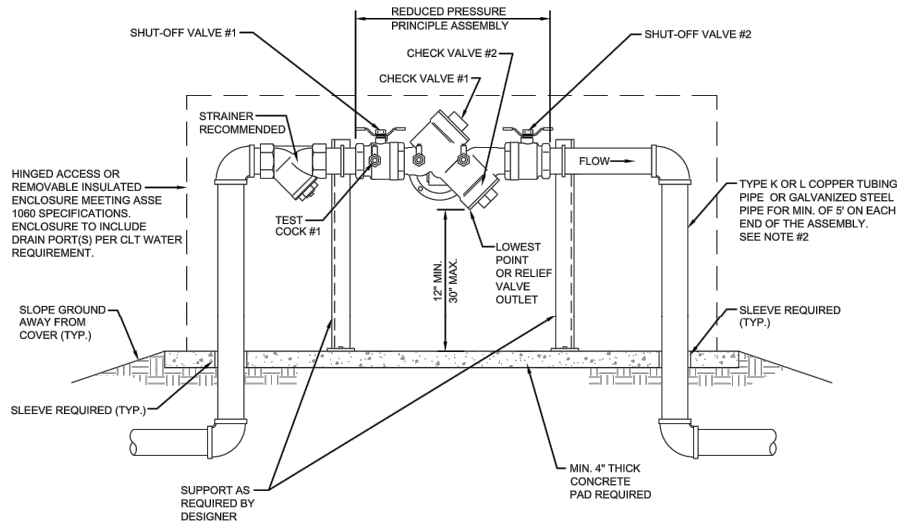

TYPICAL LOCATION REQUIREMENT FOR ABOVE GROUND INSTALLATION  
N.T.S.



# STANDARD CONSTRUCTION DETAIL

## REDUCED PRESSURE ZONE ASSEMBLY

SCALE: NTS

REVISED:  
JANUARY 2022

W14

INCLUDING THE CITY OF DAYTON STANDARD CONSTRUCTION DETAIL IN PLANS DOES NOT RELIEVE THE SEALING ENGINEER OF THE RESPONSIBILITY FOR THE SPECIFIC DESIGN. THESE DETAILS SHOULD BE CONSIDERED MINIMUM STANDARDS WHICH THE SEALING ENGINEER MAY MODIFY TO MEET SITE SPECIFIC DESIGN REQUIREMENTS.

**Appendix A:  
Road Use  
Agreement Form**



**AMENDED MASTER ROAD USE AGREEMENT**

THIS ROAD USE AGREEMENT (hereinafter “Agreement”) is made this \_\_\_\_\_ day of \_\_\_\_\_, 2021 (hereinafter “Effective Date”), by and between the CITY OF DAYTON, a Texas home rule municipality (hereinafter “City”) and \_\_\_\_\_, whose legal address is \_\_\_\_\_, its successors and assigns (hereinafter “Company”).

**RECITALS**

**WHEREAS**, Company desires to perform construction on a City drainage project on Luke Street (hereinafter “Project”); and

**WHEREAS**, Company must utilize city streets in order to access its Project; and

**WHEREAS**, Company’s agents, employees, affiliates, contractors, subcontractors, workforce and related service companies may utilize equipment and heavy vehicles that are recognized as being above existing limits set by the City in weight, height and/or width on city streets in connection with the above-described operations; and

**WHEREAS**, Company’s use of city streets may cause impacts which require mitigation and repair to ensure the public’s continued ability to use said city streets.

**NOW, THEREFORE, IT IS HEREGY AGREED THAT:**

**I. Purpose of Agreement.**

The purpose of this Agreement is to define the terms and conditions under which the City and the Company agree with respect to the cost of excess maintenance and repair of damages arising from the use of City streets by the equipment and/or heavy vehicles of the Company and/or by Contracting Companies in excess of normal wear and maintenance of city streets as carried out by the City. The Company has indicated that it intends on utilizing portions of Luke Street, Prater Street, and other city streets needed for access. Heavy equipment will be used that is normally associated with construction projects. This Agreement is intended to engage both the City and the Company in an effort to avoid damage to City streets and Appurtenances and to minimize interruptions to the traveling public. The parties acknowledge that this Agreement is entered to address these matters and to protect City streets and Appurtenances from damage.

**II. Definitions.**

- a. “Appurtenance” means a sidewalk, ditch, culvert, or any type of wall, fence, guardrail, curb, pavement marking, traffic control device, illumination device, public utility, mailbox or barrier adjacent to or in, along or on a road, or any construction, obstruction, erection or any situation, arrangement or disposition of any earth, rock, tree, or other material or thing adjacent to or in, along or on a road that is not on the traveled portion of the road.

- b. "Contracting Companies" means any agent, employee, affiliate, contractor, subcontractor, workforce or related service companies engaged by the Company in connection with the Company's installation of a pipeline.
- c. "City Streets" means a roadway under the direction, control and management of the City, including:
  - a. A developed road on which improvements such as grading or surfacing have been made for the purpose of public access and included any Appurtenances, and includes a bridge forming part of a public road and any structure incidental to a public road;
  - b. An undeveloped surveyed road allowance or road plan.

### **III. Repair and Maintenance Obligations.**

- a. The Company shall be responsible for all costs and expenses required to repair road damages in excess of Normal Maintenance (defined below) of City streets used by the Company or its Contracting Companies to conduct operations for the Project. It is the preference of the parties to this Agreement that all road repair and maintenance work be carried out by the City and reimbursed by the Company.
- b. In the event it is more practical for the Company to perform the necessary repair and maintenance work, City approval shall be required in advance of any repair and maintenance work to be performed by the Company. Any repair and maintenance work performed by the Company or its Contracting Companies shall comply with City standards. If required by the City, the Company shall provide, at its sole expense, all equipment, materials and labor required to maintain the road surface in the same condition it was immediately prior to the use of City streets.
- c. The Company and its Contracting Companies shall use best efforts to abate, control and mitigate dust generated as a result of the use of City streets.
- d. When Company operations are completed, it is agreed that the Company shall perform or provide for all necessary work on City streets used by the Company and its Contracting Companies to restore those roads to an equal or better condition as they existed on the Effective Date.
- e. During the time when the Company, or any of its Contracting Companies, is engaged in the use of a City street for access to conduct operations, the Company shall be responsible for road damage and excess maintenance resulting from such use, including but not limited to Examples of Road Damage (defined below) in this Agreement.
- f. Prior to mobilizing, Company agrees to perform a pre-construction TV inspection of the city streets being used by Company. Company also agrees to provide a copy of said videos

to the City upon request. Once Company's project is complete, Company will repair the roadways in a manner that leaves them in the same or better condition as they were prior to Company's usage of said roadways.

**IV. Term.**

This Agreement shall commence on the Effective Date and shall continue until terminated by either party upon thirty (30) days written notice being given to the other party. Notwithstanding the termination of this Agreement, the provisions respecting liability and indemnification, to the extent of liabilities that may have accrued prior to the termination, and provisions respecting settlement of accounts, shall remain in full force in accordance with their terms.

**V. Pre-Inspection Meeting.**

The Company or its designated representative shall meet with the appropriate City personnel in advance to:

- a. Confirm specific routes for heavy vehicle traffic associated with the conduct of a particular operation; and
- b. Confirm with city personnel as to the type of vehicles and duration of road use for a particular operation; and
- c. Discuss the expected damage to occur and the Company's plan for repair during the operation as well as upon completion of the operation.

**VI. Security.**

On or before the Pre-Inspection Meeting as detailed in Section V of this Agreement, the Company or its designated representative shall deliver to the City a Surety Bond or Letter of Credit in the amount ONE MILLION DOLLARS (\$1,000,000.00) based on the use of City streets by the Company during its operation.

BOND DETAILS:

---

---

---

---

**VII. Inspections.**

- a. Inspections of City streets identified in this Agreement shall be carried out at the following times in the presence of official designates of both the City and the Company at a time set by the City or the City's official designee if so agreed to by the Company:
  - a. Prior to use of City streets; and
  - b. Following completion of use of City streets.

- b. Each City street to be used by the Company or its Contracting Companies shall be inspected, photographed, and have a Pre-Con TV inspection prior to use.

### **VIII. Description of City Streets.**

- a. The Company will be responsible for all costs required to repair road damages in excess of Normal Maintenance of the City streets when used by the Company or by its Contracting Companies for the conduct of its operations. Normal Maintenance of City streets as carried out by the City includes but is not limited to the following:
  - i. Pothole patching is completed on an as needed basis.
  - ii. Grading is performed on a routine schedule based upon traffic loads and surface conditions.
  - iii. Shoulder maintenance is performed on a routine schedule, based primarily on weather conditions and as needed.
  - iv. Ditch cleaning is done as necessary, usually due to storm conditions or gradual sediment build-up.
  - v. Culvert replacement is performed as pipes wear out or are damaged.
  - vi. Culvert flushing is only necessary when pipes are plugged, which is typically due to heavy storm run-off.
  - vii. Gravel top coating is applied throughout the year as necessary.
  - viii. Asphalt-paved surfaces are maintained, as necessary with maintenance activities that include, but are not limited to pothole patching, crack sealing, and pavement failure removal and replacement.
- b. Examples of Road Damage include but are not limited to the following:
  - i. Potholes or wheel-depressed areas.
  - ii. Damage to shoulders due to heavy vehicles running off the edge of the road.
  - iii. Damage to ditches due to heavy vehicles squeezing the ditches closed by running on the shoulders of the road.
  - iv. Damage to culverts crushed by heavy hauling activities or being “plugged” by sediment from closed ditches.
  - v. Damage to road surface causing the re-cycling of the surface for the purpose of proper roadway drainage.
  - vi. Damage to the existing base by heavy traffic.
  - vii. Appropriate topping the road with driving surface aggregate after the road has been recycled or re-graded to restore a proper road profile.
  - viii. Damage to utility lines crushed by heavy hauling activities.

### **IX. City Street Use Deviations and Restrictions.**

- a. If it becomes necessary by either party to change a route of travel, the other party shall be notified in writing as soon as possible.
- b. The City reserves the right to determine the hours during which vehicles and equipment may be moved on City streets covered by this Agreement, and may temporarily suspend approvals under this Agreement if, in the opinion of the City, acting reasonably, the prevailing weather conditions, or emergencies warrant such suspension.

#### **X. Emergencies.**

The City may, in emergency situations, and acting reasonably, and without giving any notice to the Company as required elsewhere in this Agreement, take immediate and all action necessary to complete repairs to City streets that the City deems necessary for public safety.

#### **XI. Indemnification.**

The Company shall indemnify, release and hold harmless the City and its officers, agents, employees, successors and assignees from any and all actions, proceedings causes of action, claims, demands and/or costs attributable to, whether directly or indirectly, damages or injuries arising out of or resulting from acts or omissions by the Company or otherwise arising out of the performance under this Agreement by the Company, its employees, agents, contractors or subcontractors, or its Contracting Companies, but such indemnity shall not apply to the intentional acts or negligence of the City, its officers, agents, employees, successors or assignees.

#### **XII. Force Majeure.**

No party shall be deemed to be in default with respect to non-performance if due to strikes, lockouts, fire, storm, pandemics, acts of God or terrorists, or any other cause (whether similar or dissimilar to those enumerated) beyond the party's control; but lack of finances shall in no event be deemed to be a cause beyond a party's control.

#### **XIII. Assignment.**

Except as otherwise provided herein, or except as maybe hereafter determined by the parties, no party to this Agreement may sell, assign, partially assign or transfer its interest in this Agreement, or any of its rights, duties, or obligations hereunder, without the prior written consent of the other party. Whenever consent or the approval of a party is required herein, such party shall not unreasonably withhold, delay, or deny such consent of approval.

#### **XIV. Waivers.**

- a. Failure by either party to this Agreement to enforce or insist upon compliance with any of the terms or conditions of this Agreement shall not constitute a general waiver or relinquishment of any such terms or conditions, but the same shall be and remain at all times in full force and effect.

- b. By entering into this Agreement, the City does not waive, nor shall it be deemed to waive, any immunity or defense that would otherwise be available to it against claims arising by third parties.

**XV. Successors and Assigns.**

This Agreement shall inure to the benefit of and be binding upon the City and the Company and their respective successors and permitted assigns.

**XVI. Severability.**

If any provision of this Agreement shall be held invalid, illegal, or unenforceable in any respect by a court of competent jurisdiction, such invalidity, illegality or unenforceability shall not affect any other provision of this Agreement.

**XVII. Choice of Law.**

This Agreement shall be interpreted in accordance with the laws of the State of Texas, and all obligations of the parties hereto, created by this Agreement are performable in Liberty County, Texas. Venue of any suit or cause of action under this Agreement shall lie exclusively in Liberty County, Texas.

**XVIII. Entire Agreement.**

This Agreement constitutes the entire agreement and understanding between the parties and supersedes any prior agreement or understanding related to the subject matter of this Agreement.

**XIX. Modification.**

This Agreement may be modified or amended only by a duly authorized written instrument executed by the parties hereto.

**XX. Notices.**

All notices required to be given under the terms of this Agreement shall be in writing and sent via certified mail, addressed to the parties as follows:

City of Dayton:           City Manager  
                                  117 Cook St.  
                                  Dayton, TX 77535

Company: \_\_\_\_\_  
                                  \_\_\_\_\_  
                                  \_\_\_\_\_

**IN WITNESS WHEREOF**, the parties hereto have executed and delivered this Agreement as of the Effective Date.

**CITY OF DAYTON, TEXAS**

---

City Manager

**COMPANY**

---